

**LINK:
CONTENT & A-Z**



**The Ultimate
Driving Machine**



OWNER'S HANDBOOK. THE BMW 2 SERIES ACTIVE TOURER.



WELCOME TO BMW.

Owner's Handbook.

Congratulations on your choice of a BMW.

The better you are acquainted with your vehicle, the easier you will find it is to operate. We would therefore like to offer you the following advice:

Please read the Owner's Handbook before setting out in your new BMW. Also use the integrated Owner's Handbook in your vehicle. It contains important notes on how to operate the vehicle, enabling you to derive maximum benefit from the technical advantages of your BMW. It also contains information which will help you to maintain both the operating and road safety of your BMW as well as its full resale value.

If applicable, you will find updates after the editorial deadline in the appendix of the printed Owner's Handbook for the vehicle.

Supplementary information is provided in the other documents of on-board literature.

We wish you a safe and pleasant journey.

TABLE OF CONTENTS

Navigation, entertainment and communication can be accessed via the integrated Owner's Handbook in the vehicle.

NOTES

Notes	6
-------------	---

QUICK REFERENCE

Getting in	16
Adjustment and operation	20
On the move	24

OVERVIEW

Vehicle cockpit	32
iDrive	36
Voice control system	44
General settings	48
Owner's Handbook media	59

CONTROLS

Opening and closing	62
Seats, mirrors and steering wheel	84
Carrying children safely	97
Driving	107
Displays	128
Lights	145
Safety	152
Driving Stability Control Systems	175
Driving comfort	180
Air conditioning	201
Interior equipment	210
Storage compartments	221

DRIVING HINTS

Driving precautions	226
Loads	231
Trailer operation	238
Reducing fuel consumption	245

MOBILITY

Refuelling	254
Fuel	256
Wheels and tyres	262
Engine compartment	278
Engine oil	281
Coolant	285
Maintenance	287
Replacing parts	290
Help in case of a breakdown	300
General care	309

REFERENCE

Technical data	314
Seats for child restraint systems	324
Appendix	326
Everything from A to Z	328

© 2021 Bayerische Motoren Werke

Aktiengesellschaft

Munich, Germany

Not to be reproduced, wholly or in part, without written permission from BMW AG, Munich.

English ID5 II/21, 03 21 490

Printed on environmentally friendly paper, bleached without chlorine, suitable for recycling.

Notes

About this Owner's Handbook

Orientation

The quickest way to find information on a particular topic or feature is to consult the alphabetical index.

We recommend that you read through the first chapter to obtain an initial overview of the vehicle.

Updates after going to press

Updates following the copy deadline can result in differences between the printed Owner's Handbook and the integrated Owner's Handbook in the vehicle.

Notes on updates can be found in the appendix of the printed Owner's Handbook for the vehicle.

Owner's Handbook for Navigation, Entertainment, Communication

The Owner's Handbook for Navigation, Entertainment and Communication is available as a printed book from Service.

These topics are also covered in the integrated Owner's Handbook in the vehicle.

Additional sources of information

Service Partner

A Service Partner of the manufacturer will be happy to answer any further questions.

Internet

Vehicle information and general information on BMW – on technology, for example – are available on the Internet: www.bmw.com.

Integrated Owner's Handbook in the vehicle

The integrated Owner's Handbook describes the specific equipment and functions present in the vehicle. The integrated Owner's Handbook can be shown on the control display. For further information, see page 59.

BMW Driver's Guide app



The Driver's Guide app shows the most appropriate information for the selected vehicle. Where possible, only the equipment and functions actually installed in the vehicle will be described.

BMW Driver's Guide web version

The Driver's Guide web version shows the most appropriate information for the selected vehicle. Where possible, only the equipment and functions actually installed in the vehicle will be described. The Driver's Guide web version can be displayed in any up-to-date browser.

Symbols and displays

Symbols in the Owner's Handbook

Symbol	Meaning
	Precautions that must be followed in order to avoid the possibility of injury to yourself and to others as well as serious damage to the vehicle.
	Measures that can be taken to help protect the environment.
"..."	Texts on a display in the vehicle for selecting functions.
>...<	Commands for the voice control system.
>>...<<	Replies by the voice control system.

Actions

Actions that need to be carried out are shown as a numbered list. The list of steps must be carried out in the specified sequence.

1. First action.
2. Second action.

Lists

Alternative options and lists of items with no implied sequence are shown as bullet point lists:

- > First option.
- > Second option.

Symbol on components and assemblies

 This symbol on a vehicle component indicates that further information on the component is available in the Owner's Handbook.

Vehicle equipment

This Owner's Handbook describes all models and all the standard, national and optional equipment available for the model series. As a result, this Owner's Handbook may also contain descriptions and illustrations of equipment and functions which are not installed in your vehicle, for example on account of the optional equipment selected or the national-market version.

This also applies to safety-relevant functions and systems.

Please comply with the relevant laws and regulations when using the corresponding functions and systems.

If certain equipment and models are not described in this Owner's Handbook, refer to the Supplementary Owner's Handbooks provided.

In right-hand drive vehicles, some controls are arranged differently from those shown in the illustrations.

Production date

The production date of the vehicle can be found at the bottom of the door pillar on the driver's door.

The production date is defined as the calendar month and the calendar year in which the vehicle body and the powertrain assemblies are joined and the vehicle is driven or moved from the production line.

Status of the Owner's Handbook

General

The high standards of safety and quality that characterise the vehicles are ensured through ongoing development. On rare occasions, this

may mean that the features described in this handbook will vary from those in your vehicle.

For Australia/New Zealand: general

When reading this Owner's Handbook, please bear the following in mind: to ensure that our vehicles continue to embody the highest quality and safety standards, we pursue a policy of continuous, ongoing development. Because modifications in the design of both vehicles and accessories may be introduced at any time, your own vehicle's equipment may vary from that described in this handbook. For the same reason, it is also impossible to guarantee that all descriptions will be completely accurate in all respects.

We must therefore request your understanding of the fact that the manufacturer of your vehicle is unable to recognise legal claims based on discrepancies between the data, illustrations and descriptions in this Owner's Handbook and your own vehicle's equipment. Please note, too, that some of the optional equipment described in this manual is not available on Australian models due to restrictions imposed by Australian Design Rules and other requirements.

Should you require any further information, please contact your Service centre, who will be pleased to advise you.

Updates after going to press

Updates following the copy deadline can result in differences between the printed Owner's Handbook and the integrated Owner's Handbook in the vehicle.

Notes on updates can be found in the appendix of the printed Owner's Handbook for the vehicle.

Your own safety

Intended use

Please comply with the following when using the vehicle:

- ▷ Owner's Handbook.
- ▷ Information attached to the vehicle. Do not remove stickers.
- ▷ Technical data of the vehicle.
- ▷ The applicable laws and safety standards of the country in which the vehicle is used.
- ▷ Vehicle papers and legal documents.

Warranty

The vehicle is technically designed for the operating conditions and approval (homologation) requirements of the country to which it was first delivered. If the vehicle is to be driven in another country, it may need to be adapted beforehand to any different operating conditions and approval requirements prevailing in that country. If the vehicle does not comply with the homologation requirements in a certain country, no warranty claims can be lodged there for the vehicle. Warranty claims may also be invalidated if the on-board network has been modified, for example through the use of control units, hardware or software which the vehicle manufacturer classifies as unsuitable. A Service Partner is able to provide further information.

Maintenance and repairs

The advanced technology used in your vehicle, for example the state-of-the-art materials and high-performance electronics, requires appropriate maintenance and repair methods.

Consequently, the manufacturer of the vehicle recommends having corresponding work carried out by a BMW Service Partner. If another BMW authorised workshop is chosen, BMW recommends choosing one that performs work, for example maintenance and repair, according to BMW specifications with properly trained personnel. In the Owner's Handbook, facilities of this kind are referred to as "another qualified Service Partner or a specialist workshop".

If work such as maintenance and repair is carried out incorrectly, it could result in consequential damage with associated safety risks.

Work performed incorrectly on the vehicle paintwork can cause components, for example the radar sensors, to fail or malfunction, resulting in a safety risk.

Parts and accessories

BMW recommends using parts and accessories that are approved by BMW and are therefore suitable for this purpose.

You are recommended to consult a BMW Service Partner for advice on genuine BMW parts and accessories, other BMW approved products and expert advice on all related matters.

The safety and compatibility of these products in conjunction with BMW vehicles have been checked by BMW.

BMW accepts product responsibility for genuine BMW parts and accessories. On the other hand, BMW cannot accept liability for parts or accessory products of any kind which it has not approved.

BMW is unable to assess each individual product of outside origin as to its suitability for use on BMW vehicles without safety risk. Likewise no guarantee can be assumed even if the product has been granted official approval in a specific country. Tests performed for such approvals cannot always cover all operating conditions for BMW vehicles, and some of them therefore are insufficient.

Vehicle data and data protection

Responsibility and rights

Responsibility for data

Within the scope of data protection directives and legislation, the manufacturer of the vehicle is responsible for the processing of personal data which is collected when the vehicle is used or from web pages, customer support, online services and marketing campaigns.

Personal identification

Every vehicle has a unique vehicle identification number. Depending on the country, a vehicle owner can be identified with the assistance of the vehicle identification number, the number plate and the relevant authorities. There are also other ways of tracing data collected in the vehicle back to the driver or vehicle owner, for example via the ConnectedDrive account used.

Data protection laws

In accordance with current data protection law, vehicle users have certain rights they may assert against the vehicle manufacturer or companies that collect or process their personal data.

Vehicle users have a free and comprehensive right to information from organisations which save their personal data.

These organisations could be:

- ▷ Vehicle manufacturer.
- ▷ Qualified Service Partners.
- ▷ Specialist workshops.
- ▷ Service providers.

Vehicle users may request information about what personal data has been saved, what it is used for and where it has come from. Proof of ownership or use is required in order to obtain this information.

The right of access also extends to information about data that has been transferred to other companies or bodies.

Please refer to the vehicle manufacturer's website for the applicable data privacy policy. This data privacy policy contains information about the right to have data deleted or corrected. The vehicle manufacturer's website also provides its contact details and those of its data protection officer.

The vehicle owner can have the data that is stored in the vehicle read out by a Service Partner of the manufacturer or another qualified Service Partner or a specialist workshop, on payment of a fee where applicable.

The legally required on-board diagnosis OBD socket in the vehicle is used to read out the vehicle data.

Data processing

The collection of personal data may be necessary to enable the manufacturer of the vehicle to fulfil obligations to the customer or legislator or to offer high-quality products and services.

These include, for example:

- ▷ Fulfilling contractual obligations regarding the sale, servicing and repair of vehicles, for example sales processes, maintenance.
- ▷ Fulfilling contractual obligations for the provision of digital services relating to the vehicle, for example BMW ConnectedDrive.
- ▷ Ensuring product quality, research and development for new products, as well as optimising service processes.
- ▷ Performing sales, service and administration processes, including branches and National Sales Companies.
- ▷ Customer support, for example contract processing.
- ▷ Advertising communication and market research on the basis of personal consent.
- ▷ Fulfilling legal obligations, for example information regarding Technical Campaigns.
- ▷ Processing warranty claims.

Data collection

Type of data collected

Depending on the situation, the following personal data may be collected.

Contact details

Name, address, phone number, email address.

Personal data

- ▷ Personal information provided by customers, for example date of birth, education, household size or occupation.
- ▷ Data to determine identity, for example driver's licence.

Contract data

- ▷ Customer number, contract number, booked online services.
- ▷ Stored payment information, for example credit card number.

Credit rating

- ▷ Information about transactions.
- ▷ Information about fraud or criminal offences.

Interests

Information provided by the customer regarding areas of interest, for example product preferences, hobbies and other personal preferences.

Use of web pages and communication

- ▷ Information on how web pages are used and whether messages are opened or forwarded.
- ▷ Account information regarding online services, customer portals and prospective customer portals.

Transaction and interaction data

Information on the purchasing of products and services, interactions with customer support and participation in market research studies.

Use of apps and services of the vehicle manufacturer

Information on the use of apps on mobile devices and online services.

Information on vehicle functions and settings

Information on functions and settings for the vehicle, for example when using online services.

Vehicle-related sensor data and usage data

Data which is generated and/or processed in the vehicle.

- ▶ Driver assistance systems: processing sensor data which is used to evaluate the vehicle surroundings or the driver's behaviour.
- ▶ Personal settings: settings saved in the vehicle profile, for example seat setting.
- ▶ Multimedia, navigation, for example destinations.

Time of data collection

Personal data may be collected at the following times:

- ▶ When the customer makes direct contact with the manufacturer of the vehicle, for example via the web page.
- ▶ When requesting information on products and services or direct purchases, for example on web pages or in apps.
- ▶ When making direct purchases, for example on the web page.
- ▶ When purchasing services directly, for example online services.
- ▶ When responding to the customer regarding direct marketing activities, for example when personal data is provided.
- ▶ When using vehicles, products, services and digital offers, for example web pages, apps.
- ▶ When transferring personal data through qualified partners of the vehicle manufacturer or through third-party providers, provided that data protection requirements are met.
- ▶ When providing personal data through certified address providers, provided that data protection requirements are met.
- ▶ When reading out vehicle data, including the vehicle identification number, during service and repair activities.

Data in the vehicle

General

A number of electronic control devices are installed in your vehicle. Electronic control units process data that they receive from vehicle sensors, generate themselves or exchange with one another, for example. A high number of control units are necessary for the vehicle to function safely or provide assistance during driving, for example driver assistance systems. There are also control devices which manage comfort or information functions.

Data saved in the vehicle can be deleted at any time. This data is only transmitted to third parties if expressly requested in the course of using online services. The transfer depends on the settings selected for using the services.

Sensor data

Driver assistance systems, for example Active Cruise Control, collision warning or Attentiveness Assistant, process sensor data which is used to evaluate the vehicle surroundings or the driver's behaviour.

These include, for example:

- ▶ Status reports relating to the vehicle and its individual components, for example wheel speed, wheel circumferential velocity, deceleration, lateral acceleration, fastened seat belts.
- ▶ Ambient conditions, for example temperature, rain sensor signals.

The data is processed within the vehicle and is usually transient. It is only saved for longer than the operating period if it is required in order to provide services agreed with the customer.

Electronic components

Electronic parts, for example control devices and vehicle keys, contain components for storing technical information. Information about the vehicle's condition, component use and wear, main-

tenance requirements, events or errors can be stored temporarily or permanently.

This information generally documents the condition of a component, a module, a system or the vehicle surroundings, including:

- ▷ Operating states of system components, for example fill levels, tyre inflation pressure, battery status.
- ▷ Malfunctions and faults of important system components, for example lights and brakes.
- ▷ Responses of the vehicle to particular driving situations, for example triggering of an airbag, activation of the driving stability control systems.
- ▷ Information on vehicle-damaging events.

The data is required so that the control units can perform their functions. It is also used for detecting and rectifying malfunctions, as well as to optimise vehicle functions.

Most of this data is transient and is only processed within the vehicle itself. Only a small proportion of the data is stored in event or error memories in response to specific circumstances.

Personal settings

Convenience functions, such as seat, climate or light settings, make every journey even more pleasant. The personal settings for these functions can be saved in a profile within the vehicle and retrieved on request, for example if the settings have been changed by another driver. Depending on the equipment, these profiles can be saved in the vehicle manufacturer's secure data systems. When the driver changes vehicle, these saved profiles can simply be applied to a different vehicle.

The vehicle settings saved in the vehicle profile can be changed or deleted at any time.

Multimedia and navigation

Data can also be imported into the vehicle entertainment and communication system, for example via a smartphone or MP3 player. The impor-

ted data can be processed within the vehicle, for example to play the user's favourite music.

Depending on the vehicle equipment, this data includes:

- ▷ Multimedia data such as music, films or photos for playback in an integrated multimedia system.
- ▷ Address book data for use in conjunction with an integrated hands-free system or an integrated navigation system.
- ▷ Destinations: depending on the equipment, route guidance can be started automatically with the aid of destinations which have been taught in by the navigation system.
- ▷ Data on usage of Internet services.

This data may be saved locally in the vehicle or stored on a device that has been connected to the vehicle, for example a smartphone, USB stick or MP3 player.

Service data

General

When service work is required, for example repairs, service operations, warranty work and quality assurance measures, this technical information can be read out from the vehicle together with the vehicle identification number.

Stored data

Electronic vehicle components may contain data storage media which store technical information relating to the vehicle condition, events and errors. The data required for service measures is processed locally and is deleted automatically once the work is complete. A Service Partner of the manufacturer or another qualified Service Partner or a specialist workshop can read out the information. As part of service and repair orders, data is read out via the OBD diagnostic socket using special diagnosis systems and transferred to the vehicle manufacturer. The customer is entitled to object to the data being read out and forwarded.

Optimising service processes

The vehicle manufacturer maintains documentation relating to each vehicle to ensure the best possible service is provided. Within the scope of legal requirements, this documentation may be made available to authorised third parties, for example specialist workshops.

The independent operators may only use this data for the purposes of performing the service or repair order in question. This prevents work from being duplicated unnecessarily on the vehicle, for example.

Ensuring product quality

The data logs the technical conditions of the vehicle and helps in locating errors, complying with warranty obligations and improving quality.

To ensure product quality and the development of new products, data on the usage of individual components and systems may be read out, for example lights, brakes, power windows, displays. This data helps the vehicle manufacturer to optimise the design of components and systems. Data analysis also provides the basis for Technical Campaigns and statutory recalls.

Furthermore, the manufacturer has product monitoring obligations to meet in line with product liability law. To fulfil these obligations, the vehicle manufacturer requires technical data from the vehicle.

Goodwill and warranty claims

Data from the vehicle can also be used to check customer warranty claims. If goodwill or warranty claims are asserted, the data is read out and transferred to the vehicle manufacturer to resolve the claims promptly.

Error and event memories in the vehicle can be reset when a Service Partner of the manufacturer or another qualified Service Partner or a specialist workshop performs repair or servicing work.

Control over data

Data transferred to the vehicle manufacturer for the purposes of ensuring product quality or optimising service processes can be prevented upon request.

Legal requirements regarding data disclosure

According to current law, the vehicle manufacturer is obliged to provide the authorities with any data it has stored. Data is provided to the extent required and on a case-by-case basis, for example to investigate a criminal offence.

The current law also gives state bodies authorisation to read out data from the vehicle themselves for individual cases. This could include reading out data from the airbag control device to shed light on the circumstances of an accident, for example.

Mobile devices

Depending on the equipment, mobile devices such as smartphones can be connected to the vehicle and used to control vehicle functions, for example BMW Connected, Apple CarPlay. Sound and images from the mobile device may be played back or displayed through the multimedia system in the vehicle, for example.

Selected information is transferred to the mobile device at the same time. Depending on the type of integration, this includes position data and other general vehicle information, for example. This enables optimum use of selected apps, for example navigation and music playback. How the data is processed further is determined by the provider of the particular app being used.

Services

General

If the vehicle has a wireless network connection, this enables data to be exchanged between the vehicle and other systems, for example with BMW ConnectedDrive.

Services from the vehicle manufacturer

In the case of online services provided by the manufacturer of the vehicle, the respective functions are described at a suitable point, for example, in the Owner's Handbook or on the manufacturer's web page. The relevant legal information pertaining to data protection is also provided.

Personal data may be used to provide online services. Data is exchanged over a secure connection, for example with the data systems of the vehicle manufacturer intended for this purpose.

Any collection, processing and use of personal data above and beyond that needed to provide the services always requires legal permission, a contractual agreement or consent of the user.

BMW ConnectedDrive

BMW ConnectedDrive networks the vehicle with a whole host of digital services. When used, only the data saved in the vehicle that is required to perform the agreed service is transferred online, for example information on identifying and locating the vehicle. The basis is a contractual agreement with the user.

In individual cases, the transfer of data is triggered as a result of predefined events, such as an intelligent emergency call. The wireless network connection is established via an in-vehicle transmitter and receiver unit or via personal mobile devices brought into the vehicle, for example smartphones. Data transfer can be deactivated on request.

The wireless network connection enables online functions to be used. These include online services and apps supplied by the vehicle manufacturer or by other providers.

Services from other providers

When using online services from other providers, these services are the responsibility of the relevant provider and subject to their data privacy conditions and terms of use. The vehicle manu-

facturer has no influence over the data that is exchanged.

Information as to how personal data is collected and used in relation to services from third parties, the scope of such data and its purpose, can be obtained from the relevant provider.

Personal decision

Every user decides for themselves whether they wish to enter into a contract for a service such as BMW ConnectedDrive. Information is provided in writing regarding the scope and content of data processing before the service is acquired and forms part of the vehicle handover.

The user has the option to deactivate the services at any time and, as a result, to stop the processing of data required for the services. It is also possible to have the entire data connection activated or deactivated. Excluded from this are functions and services which are required by law, for example emergency call systems.

Transparency concerning vehicle data

BMW CarData provides transparency regarding how vehicle data is handled when BMW ConnectedDrive is used. BMW CarData enables users to control whether vehicle data that is processed in the context of BMW ConnectedDrive is transferred to third parties. Users can decide for each individual service offering whether data access is to be granted or refused for third parties, for example for insurance companies.

An archive from BMW CarData can also be requested at any time. The archive provides information regarding the data that has been transmitted and saved in the context of BMW ConnectedDrive. BMW CarData can only be accessed by third-party providers via servers of the vehicle manufacturer. No direct access to the vehicle and its data is granted.

More information on BMW CarData is available on the BMW ConnectedDrive customer portal.

Vehicle identification number

General

Depending on the national-market version, the vehicle identification number is located at different positions in the vehicle. This chapter describes all the positions that are possible for the model range.

Engine compartment

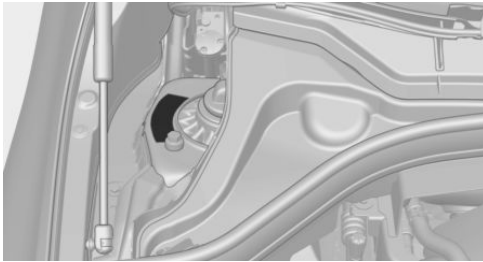

The vehicle identification number is engraved in the engine compartment, on the right-hand side of the vehicle.

Type plate on right-hand side

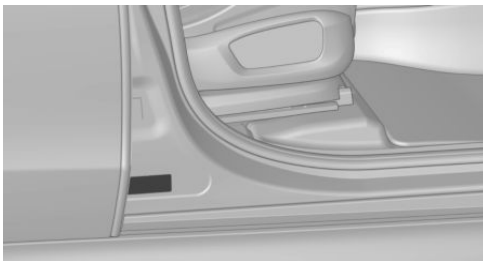

The vehicle identification number is on the type plate on the right-hand side of the vehicle.

Type plate on left-hand side

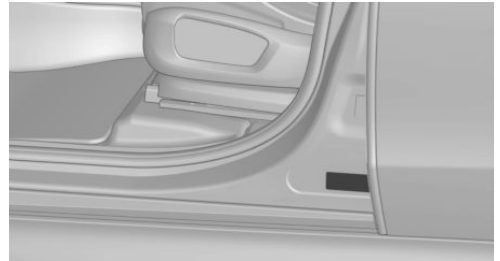

The vehicle identification number is on the type plate, on the left-hand side of the vehicle.

Windscreen



The vehicle identification number is additionally located behind the windscreen.

iDrive

It is also possible to display the vehicle identification number via iDrive, see page [53](#).

Getting in

Opening and closing

Buttons on the vehicle key

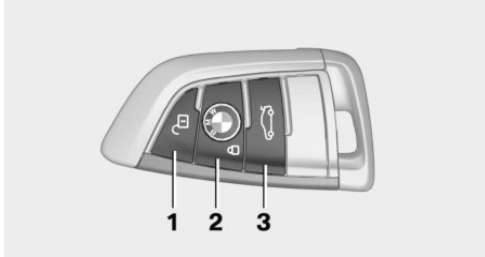

- 1 To unlock
- 2 To lock
- 3 To unlock the tailgate

With automatic tailgate operation: to open/
close the tailgate

Unlocking the vehicle



Press the button on the vehicle key.

Depending on the settings, only the driver's door or all vehicle access points are unlocked.

If only the driver's door is unlocked, press the button on the vehicle key again to unlock the other vehicle access points.



Keep the button on the vehicle key pressed after unlocking.

The windows and the glass sunroof are opened for as long as the button on the vehicle key is pressed.

Locking the vehicle



Press the button on the vehicle key.

All vehicle access points are locked.



Keep the button on the vehicle key pressed after locking.

The windows and the glass sunroof are closed for as long as the button on the vehicle key is pressed.

Central locking buttons

Overview



Central locking buttons.

Locking



Press the button with the front doors closed.

The fuel tank filler flap remains unlocked.

Unlocking



Press the button.

Comfort Access

Principle

This feature allows you to access the vehicle without having to operate the vehicle key.

Simply having the vehicle key with you, for example in your trouser pocket, is sufficient.

The vehicle automatically recognises the vehicle key when it is in the immediate vicinity or inside the vehicle.

Unlocking the vehicle



Completely grip handle of the driver's or front passenger door.

Locking the vehicle



With your finger, touch the area on the door handle of the driver's or front passenger door for approximately 1 second, without gripping the door handle.

With automatic operation of the tailgate: opening and closing the tailgate contactlessly

Principle

The tailgate can be opened and closed contactlessly, provided you are carrying the vehicle key with you.

Correct foot movement

1. Stand in the centre behind the vehicle, approximately an arm's length away from the rear of the vehicle.
2. Kick your foot as far as possible underneath the vehicle and immediately pull it back. Your leg must move through the ranges of both sensors.

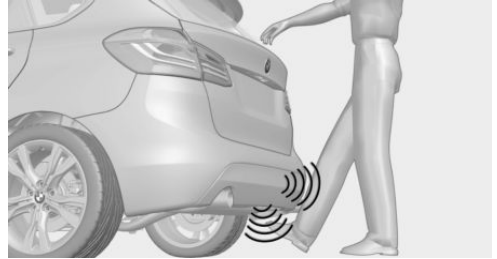

Tailgate

Opening



- ▷ Unlock the vehicle and press the button on the tailgate.
- ▷ If you are carrying the vehicle key, press the button on the tailgate.
- ▷  Press the button on the vehicle key for approximately 1 second.
If applicable, the doors are also unlocked.

Closing



▷ Press the button on the inside of the tailgate, arrow 1.

▷ Press the button, arrow 2.

The vehicle is locked after the tailgate has been closed. For this to happen, the driver's door must be closed and the vehicle key must be outside the vehicle in the vicinity of the tailgate.

▷  Press and hold the button on the vehicle key until the tailgate has closed.

Displays and controls

Around the steering wheel



- 1 Light switch element
- 2 High-beam headlights, flasher, indicator
- 3 Instrument cluster
- 4 Wiper system
- 5 Start/Stop button

Indicator and warning lamps

Indicator and warning lamps can illuminate in a variety of combinations and colours.

When the engine starts or the ignition is switched on, the functionality of some lights is checked and they illuminate briefly.

Driver's door



- 1 Safety switch
- 2 Power window switches
- 3 Exterior mirrors
- 4 With automatic tailgate operation: to open/close the tailgate

Switch cluster

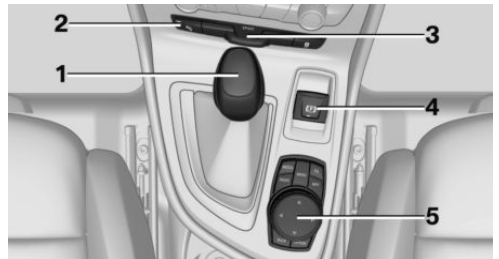







- 1 Selector lever
- 2 Driver assistance systems
- 3 Driving Experience Control
- 4 Parking brake
- 5 Controller

iDrive

Principle

iDrive brings together the functions of a number of switches. These functions can be operated using the Controller.

Buttons on the Controller

Button	Function
	Press once: to call up the main menu. Press twice: shows all menu items of the main menu.
	To call up the Communication menu.
	To call up the Media/Radio menu.
	To call up the destination entry menu of the navigation system.
	To call up the navigation map.
	Press once: to call up the previous screen. Press and hold: to call up the recently used menus.
	To call up the Options menu.

Voice control

Activating the voice control system

-  Press the button on the steering wheel.
- Wait for the acoustic signal.
- Say the command.

 This symbol indicates that the voice control system is active.

If no further spoken commands are possible, switch to iDrive to operate the function.

Switching off the voice control system



Press the button on the steering wheel or say ›Cancel.

Adjustment and operation

Seats, mirrors and steering wheel

Manually adjustable seats

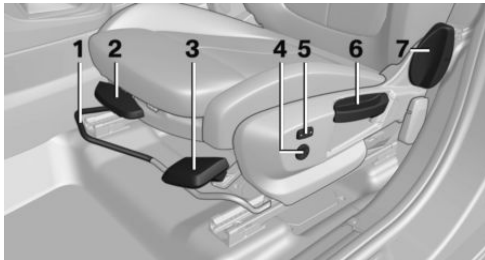

- 1 Longitudinal direction
- 2 Thigh support
- 3 Seat angle
- 4 Lumbar support
- 5 Backrest width
- 6 Height
- 7 Backrest angle

Electrically adjustable seats

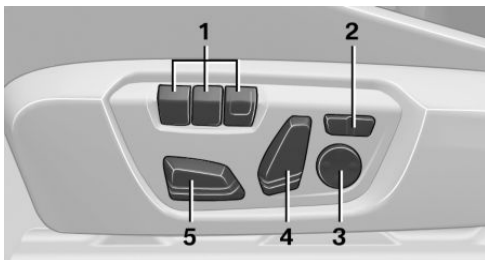

- 1 Memory function
- 2 Backrest width
- 3 Lumbar support
- 4 Backrest angle
- 5 Longitudinal direction, height, inclination

Adjusting the head restraint

Height

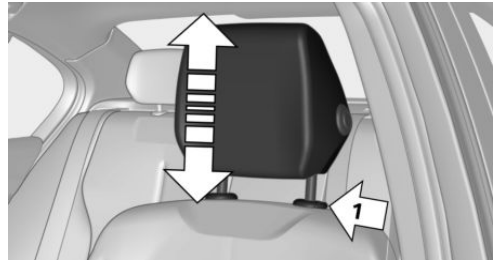

- ▷ Up: push the head restraint upwards.
- ▷ Down: press the button, arrow 1, and slide the head restraint downwards.

Adjusting the exterior mirrors



- 1 To adjust
- 2 To select a mirror, automatic parking function
- 3 Folding in and out

To adjust the steering wheel

Manual steering wheel adjustment

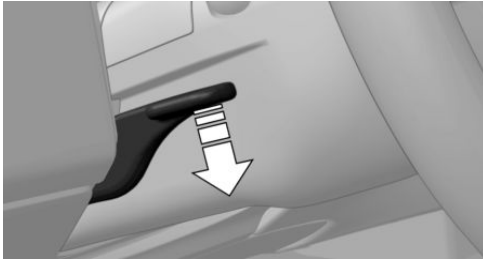

1. Switch on the ignition.
2. Fold the lever down.
3. Move the steering wheel to the preferred height and angle to suit your seating position.
4. Fold the lever back up.
5. Switch off the ignition again if necessary.

Memory function

Principle

The memory function enables the following settings to be stored and retrieved when required:

- ▷ Seat position.
- ▷ Exterior mirror position.
- ▷ Height of the Head-Up Display.

Saving

1. Switch on the ignition.
2. Set the desired position.
3.  Press the button. The LED in the button is illuminated.
4. Press the desired button 1 or 2 while the LED is illuminated. The LED is extinguished.

Retrieving settings

Press the desired button 1 or 2.

The saved position is retrieved automatically.

The operation is halted when you press a seat adjustment switch or one of the memory buttons.

Adjustment of the driver's seat position is disabled a short while after driving off.

Infotainment

Depending on the national-market version: radio

Controls

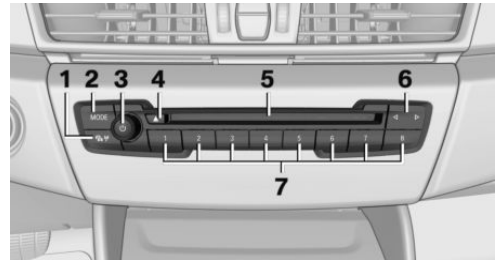

- 1 Traffic information
- 2 To change the entertainment source
- 3 Sound output on/off, volume
- 4 Depending on the equipment: to eject a CD/DVD
- 5 Depending on the equipment: CD/DVD drive
- 6 To change station/track
- 7 Functional bookmarks

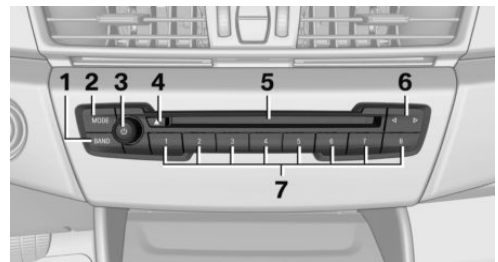

- 1 To change waveband
- 2 To change the entertainment source

- 3 Sound output on/off, volume
- 4 Depending on the equipment: to eject a CD/DVD
- 5 Depending on the equipment: CD/DVD drive
- 6 To change station/track
- 7 Functional bookmarks

Navigation destination entry

Entering the destination using an address

Via iDrive:

Country

1. "Navigation"
2.  "Address input"
3. "Country?"
4. Select the country from the list.

Entering an address

1. "City/town or postcode?"
2. Enter letters or numbers.
3. Tilt the Controller to the right to select the town/city or postal code from the list.
4. "Street?"
5. Enter the street in the same way as for the town/city.
6. "House number/road junction?"
7. Switch to the list of house numbers and junctions.
8. Select the house number or junction.

Starting route guidance

"Start route guidance"

If only the town/city has been entered, route guidance guides you to the town/city centre.

Connecting mobile telephone

After the mobile telephone has been paired with the vehicle in a one-off process, it can be oper-

ated using the iDrive, the buttons on the steering wheel and by voice control.

1. "My Vehicle"
2. "iDrive settings"
3. "Mobile devices"
4. "Connect new device"
5. Select functions for which you would like to use the mobile telephone.

The Bluetooth name of the vehicle is shown on the control display.

6. To perform further steps on the mobile telephone, such as searching for/connecting a Bluetooth device or new device, please refer to the mobile telephone's operating instructions.

The Bluetooth name of the vehicle is shown on the display of the mobile telephone. Select the vehicle's Bluetooth name.

7. Depending on the mobile device, either a control number is displayed, or you will have to enter the control number yourself.

- ▶ Compare the control number shown on the control display with the control number on the device display.

Confirm the control number on the device and on the control display.

- ▶ Enter the same control number on the device and via iDrive then confirm.

The device is connected and displayed in the device list.

Telephony

Accepting a call

Incoming calls can be accepted using the iDrive or using the button on the steering wheel.

Via iDrive

-  "Accept"

Via button on the steering wheel

Press the button.

Dialling a number

1. "Communication"
2. "Dial number"
3. Enter the numbers.
4.  Select the symbol. The call is made using the mobile telephone to which the telephone function is assigned.

To make a call via the additional telephone:

1.  Press the button.
2. "Call via"

Apple CarPlay preparation**Principle**

CarPlay makes it possible to operate certain functions of a compatible Apple iPhone by Siri voice operation and using iDrive.

Operating requirements

- ▷ Compatible iPhone: iPhone 5 or later with iOS 7.1 or later.
- ▷ Appropriate mobile radio contract.
- ▷ Bluetooth, WLAN and Siri voice operation are activated on the iPhone.
- ▷ WLAN and Bluetooth are activated in the vehicle.
- ▷ The setting for mobile data may need to be activated on the iPhone.

Switching on Bluetooth and CarPlay

Via iDrive:

1. "My Vehicle"
2. "iDrive settings"
3. "Mobile devices"
4. "Settings"
5. Select the following settings:

- ▷ "Bluetooth"
- ▷ "Apple CarPlay"

Pairing the iPhone with CarPlay

Pair the iPhone with the vehicle via Bluetooth.

Select CarPlay as the function:

- ▶  "Apple CarPlay"

The iPhone is connected to the vehicle and displayed in the device list.

On the move

Driving

Starting and stopping the engine

Ignition on/off



- ▶ On: press the Start/Stop button.

Most of the indicator and warning lamps illuminate for varying lengths of time.

- ▶ Off: press the Start/Stop button again.
All indicator lamps turn off.
- ▶ Radio-ready state: with the ignition switched off, press the on/off button on the radio or with the engine running, press the Start/Stop button.
Individual power consumers remain operational.

Starting/stopping engine

Steptronic transmission: starting

1. Press the brake.
2. Press the Start/Stop button.

Manual transmission: starting

1. Press the brake.
2. Press the clutch and engage idle position.
3. Press the Start/Stop button.

Steptronic transmission: stopping

1. Apply the parking brake when the vehicle is stationary.
2. Engage selector lever position P.
3. Press the Start/Stop button.

Manual transmission: stopping

1. Press the Start/Stop button when the vehicle is at standstill.
2. Engage first gear or reverse.
3. Apply the parking brake.

Automatic Start/Stop function

Manual transmission: switches the engine off automatically when stationary to save fuel. As soon as the clutch pedal is depressed, the engine starts automatically.

Steptronic transmission: Switches the engine off automatically when stationary to save fuel. As soon as the brake pedal is released, the engine starts automatically.

Parking brake

Engaging



Pull the switch.

The LED on the switch and the indicator lamp in the instrument cluster are illuminated.

Releasing



With the ignition switched on:

Manual transmission: press the switch while pressing the brake or the clutch.

Steptronic transmission: with the brakes applied or selector lever in position P, press the switch.

The LED and indicator lamp are illuminated.

The parking brake is released.

Manual transmission

Shifting gears

When shifting into a lower gear, high engine speeds can damage the engine. There is a risk of material damage. Push the shift lever to the right while shifting into the 5th or 6th gear.

Reverse gear

Engage this position only when the vehicle is stationary.

To overcome the resistance, move the shift lever firmly to the left towards the left and engage the reverse gear with a gear shift movement forwards.

Steptronic transmission

Selector lever positions

P Park position.

R Reverse.

N Neutral.

D Drive position.

Only engage selector lever position P or R when the vehicle is stationary.

Apply the brakes until ready to drive off, otherwise the vehicle will move when drive position or reverse gear is selected.

Selector lever lock

A lock prevents an inadvertent change from selector lever position P to another selector lever position and, depending on the transmission version, inadvertent shifting from selector lever position P or R.

To cancel the lock: with the brake pedal pressed, press the button on the front or side of the selector lever.

Steptronic transmission, sport program and manual mode

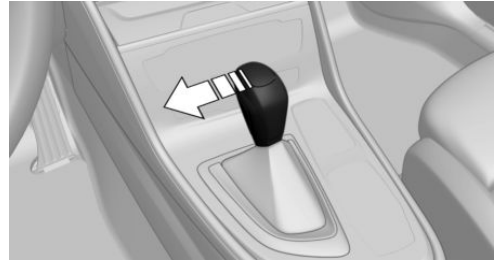

Sport programme:

Push the selector lever out of selector lever position D to the left.

Manual operation:

- ▶ To shift down: press the selector lever forwards.
- ▶ To shift up: pull the selector lever backwards.

High-beam headlights, headlight flasher, turn indicators, parking lights

High-beam headlights, headlight flasher

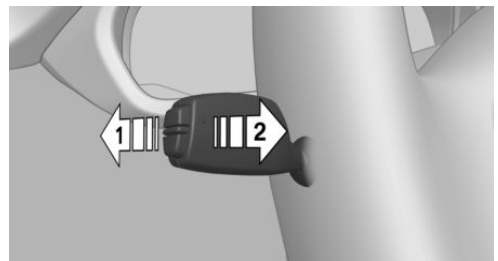

Push the lever forwards or pull it back.

- ▶ High-beam headlights on, arrow 1.
The high-beam headlights are illuminated when the low-beam headlights are switched on.
- ▶ High-beam headlights off/headlight flasher, arrow 2.

Turn indicator

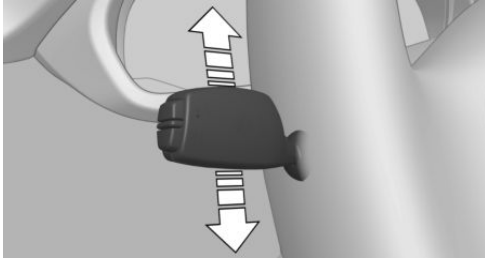

- ▶ On: press the lever beyond the resistance point.
- ▶ Off: lightly tap the lever as far as the resistance point.
- ▶ Triple turn signal: lightly tip the lever up or down.
- ▶ To indicate a turn briefly: press the lever as far as the resistance point and hold it there for as long as you wish to indicate a turn.

Parking light

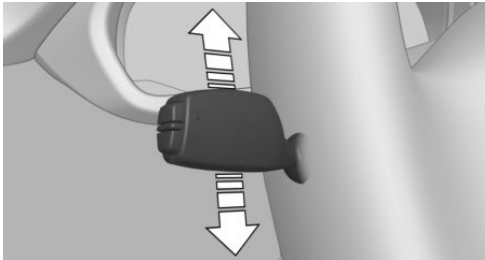









Illuminate the vehicle on one side.

- ▶ On: with the ignition switched off, push the lever upwards or downwards beyond the resistance point for approximately 2 seconds.
- ▶ Off: press the lever briefly in the opposite direction as far as the resistance point.

Lights and lighting

Light functions

Symbol	Function
	Front fog lights.
	Rear fog light.
	Automatic driving lights control. Adaptive light functions
	Lights off. Daytime running lights.
	Side lights.
	Low-beam headlights.
	Manual headlight beam throw adjustment.
	Instrument lighting.

Wiper system

Switching the wipers on/off and flick-wiping

Switching on

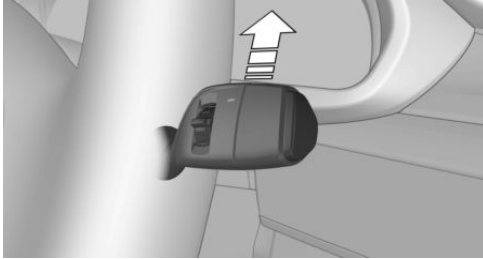

- ▶ Normal wiping speed: tap up once.
- ▶ Fast wiping speed: press upwards twice or press once beyond the resistance point.

Switching off and flick-wiping

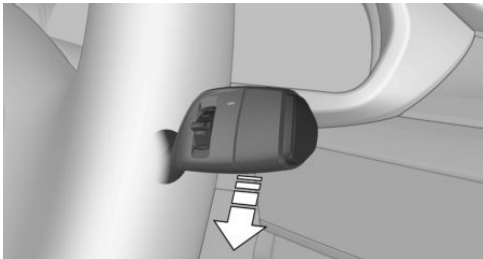

Press the wiper lever downwards.

- ▶ To flick-wipe: press downwards once.
- ▶ Switching off normal mode: press downwards once.
- ▶ To switch off fast mode: press down twice.

Rain sensor

Activating/deactivating

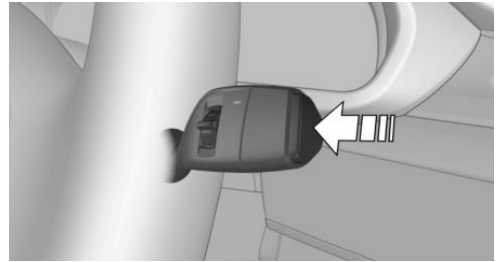

Press the button on the wiper lever.

Adjusting the sensitivity

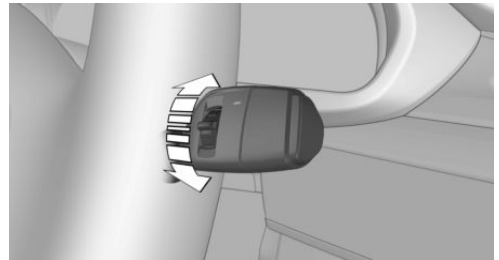

Turn the knurled wheel on the wiper lever.

Cleaning the windscreen

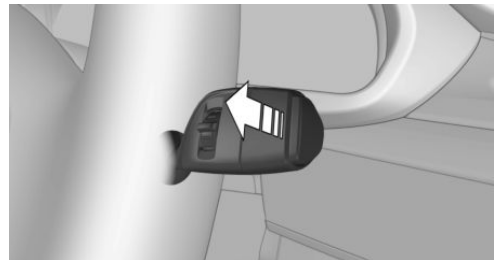

Pull the wiper lever.

Rear wiper

Switching on

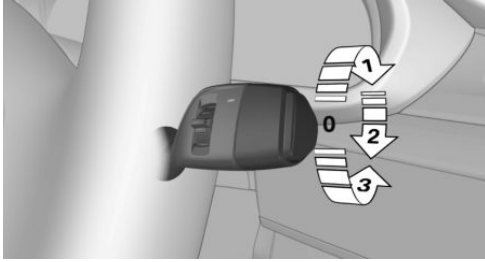

Turn the outer switch upwards.

- ▷ Park position of the wiper, position 0.
- ▷ Intermittent mode, arrow 1. Engaging reverse gear activates continuous operation.

Cleaning the rear window

Turn the outer switch in the desired direction.

- ▷ In wiper park position: turn the switch downwards, arrow 3. The switch returns to the park position when released.
- ▷ In intermittent mode: turn the switch further, arrow 2. The switch returns to the intermittent position when released.

Air conditioning



Air conditioning system

Button	Function
	Temperature.
	Cooling function.
	Recirculated-air mode.

Button	Function
	Air flow, manual.
	Air distribution, manual.
	Rear window heating.
	Seat heating.

Automatic air conditioning

Button	Function
	Temperature.
	Cooling function.
	Maximum cooling.
	AUTO program.
	Recirculated-air mode/AUC.
	Air flow, manual.
	Air distribution, manual.
	SYNC program.
	Window defrost/demist
	Rear window heating.

Button	Function
	Seat heating.
	Switch off the system.

Refuelling stop

Refuelling

Fuel filler cap

1. To open the fuel tank filler flap, push on the upper edge, arrow. The fuel tank filler flap opens.



2. Turn the fuel filler cap anticlockwise.
3. Place the fuel filler cap in the holder on the fuel tank filler flap.

Petrol

For optimal fuel consumption, the petrol should be sulphur-free or have a low sulphur content. Only refuel with unleaded petrol without metallic additives.

Information about the recommended petrol grade is provided in the Owner's Handbook.

Diesel

Diesel fuel to DIN EN 590 standard.

Wheels and tyres

Tyre inflation pressure information



The tyre inflation pressures are on the plate on the door pillar.

After adjusting the tyre inflation pressure

For the runflat indicator RPA: reinitialise the run-flat indicator RPA.

For the Tyre Pressure Monitor TPM: reset the Tyre Pressure Monitor TPM.

Checking the tyre inflation pressure

Check regularly and adjust as necessary:

- ▷ At least twice a month.
- ▷ Before a long journey.

Electronic oil measurement

Requirements

A current reading is available after approximately 30 minutes into the journey. On shorter journeys, the status of the last sufficiently long journey is shown.

Displaying the engine oil level

1. "My Vehicle"
2. "Vehicle status"
3.  "Engine oil level"

Adding engine oil

General

Switch off the ignition and park the vehicle safely before topping up with engine oil.

Adding engine oil

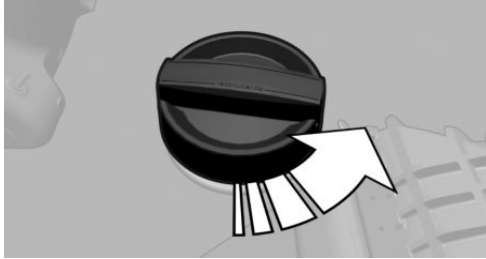

Do not top up engine oil unless a message is displayed in the instrument cluster.

Note the top-up quantity in the message.

Do not add too much engine oil.

Use the recommended oil grades.

How to get assistance

Hazard warning lights

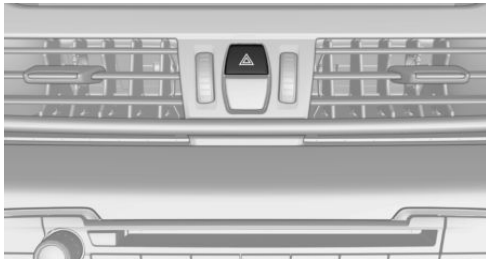

The button is located in the centre console.

Help in case of a breakdown

BMW Emergency Service

Via iDrive:

1. "ConnectedDrive"
2. "BMW Assistance"
3. "BMW Roadside Assistance"

A voice connection to BMW Roadside Assistance is established.

ConnectedDrive

Concierge Service

Phone numbers and addresses of hotels, emergency chemists etc., can be sent to the vehicle and called directly or adopted as destinations in the navigation system.

1. "ConnectedDrive"
2. "Concierge Services"

Teleservices

Teleservices are services that help to keep the vehicle mobile.

Depending on equipment, Teleservices includes the following services:

- ▷ Roadside Assistance.
- ▷ Teleservice Call.
- ▷ Automatic Teleservice Call.
- ▷ Teleservice Report.
- ▷ Teleservice Battery Guard.
- ▷ Your Service Partner.

Vehicle cockpit

Vehicle equipment

This chapter describes all standard, country-specific and optional equipment available for the model series. It may therefore describe equipment and functions which are not installed in

your vehicle, for example on account of the optional equipment selected or the national-market version. This also applies to safety-relevant functions and systems. Please comply with the relevant laws and regulations when using the corresponding functions and systems.

Around the steering wheel

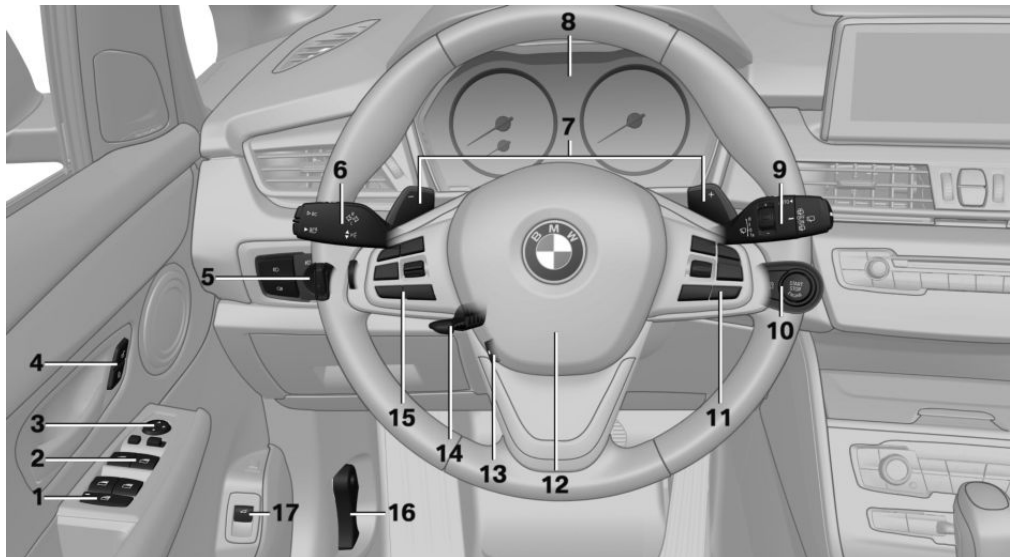

- 1 Safety switch for windows in rear passenger compartment [80](#)
- 2 Power window switches [79](#)
- 3 Exterior mirror operation [94](#)
- 4 Central locking system



To unlock [67](#)



To lock [67](#)

- 5 Lights



Front fog lights [149](#)































Rear fog light [149](#)



Light switch [145](#)



Lights off
Daytime running lights [147](#)

-  Side lights [145](#)
-  Low-beam headlights [146](#)
-  Automatic driving lights control [146](#)
-  Adaptive light functions [147](#)
-  High beam assistant [148](#)
-  Instrument lighting [150](#)
-  Manual headlight beam throw adjustment [148](#)
- 6** Steering-column lever, left
-  Turn indicator [114](#)
-  High-beam headlights, headlight flasher [114](#)
-  High beam assistant [148](#)
-  Parking lights [146](#)
-  On-board computer [138](#)
- 7** Shift paddles [120](#)
- 8** Instrument cluster [128](#)
- 9** Steering-column lever, right
-  Wipers [115](#)
-  Rain sensor [116](#)
-  To clean the windscreen [117](#)
-  Rear wiper [117](#)
-  To clean the rear window [117](#)
- 10**  Engine start/stop and ignition on/off [108](#)
-  Automatic Start/Stop function [110](#)
- 11** Buttons on steering wheel, right
-  Entertainment source
-  Volume control
-  Voice control [44](#)
-  Telephone, see Owner's Handbook for Navigation, Entertainment, Communication [6](#)
- Knurled wheel for selection lists [138](#)
- 12**  Horn, entire area
- 13**  Steering wheel heating [96](#)
- 14** To adjust the steering wheel [96](#)
- 15** Buttons on steering wheel, left
-  Speed limiter [171](#)
-  Cruise Control on/off [186](#)
-  Active Cruise Control on/off [180](#)
-  To interrupt, resume Cruise Control



Camera-based Cruise Control: to reduce the distance



Camera-based Cruise Control: to increase the distance

Cruise Control rocker switch

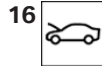

To unlock the bonnet 279

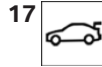

With automatic tailgate operation: to open/close the tailgate 71

Around the centre console

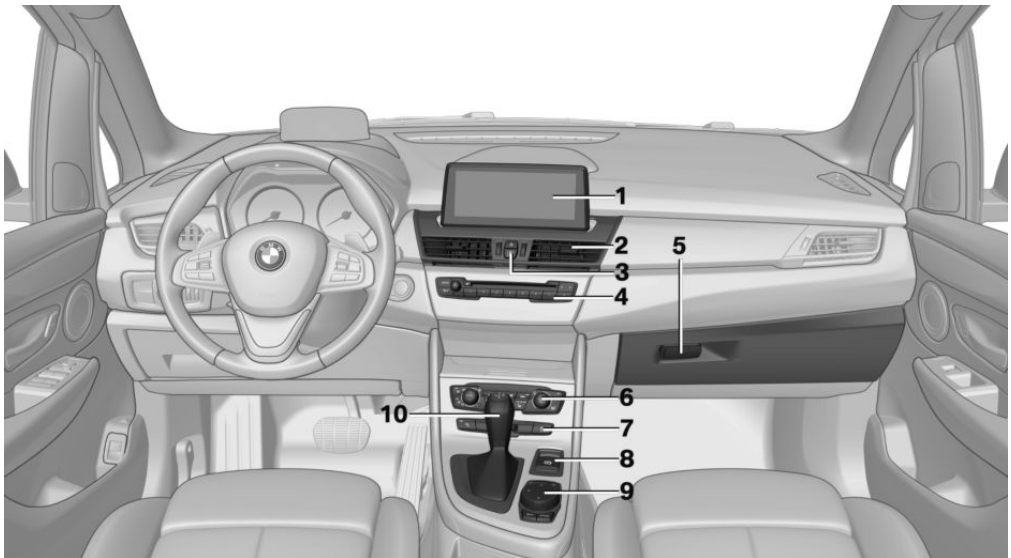

1 Control display 36

2 Ventilation 207

3  Hazard warning lights 300



Intelligent Safety 163

4 Radio/Multimedia

5 Glove compartment 222

6 Climate 201

7  Park Distance Control, PDC 189

Reversing Assist camera 192

Park Assist 196



Dynamic Stability Control, DSC 175



Driving Experience Control 177

8 Parking brake 112

9 Controller with buttons 38

10 Steptronic transmission selector lever 120

Manual transmission gearshift lever 119

Around the headliner

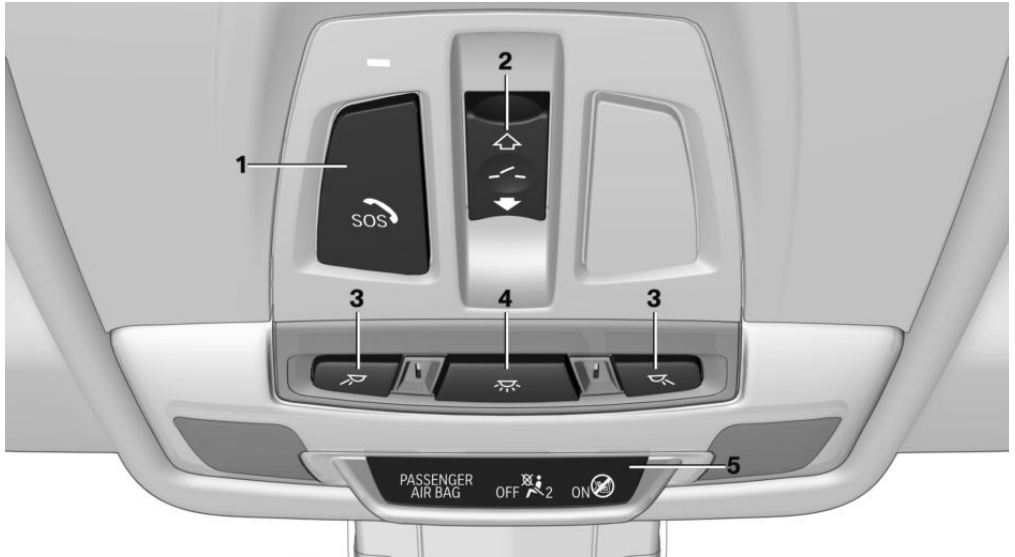
1  Emergency call, SOS 3014  Interior light 1502  Glass sunroof 815  Front passenger airbag indicator lamp 1553  Reading lights 150

iDrive

Vehicle equipment

This chapter describes all standard, country-specific and optional equipment available for the model series. It may therefore describe equipment and functions which are not installed in your vehicle, for example on account of the optional equipment selected or the national-market version. This also applies to safety-relevant functions and systems. Please comply with the relevant laws and regulations when using the corresponding functions and systems.

Principle

iDrive brings together the functions of a number of switches. These functions can be operated using the Controller and, depending on the equipment version, the touchscreen.

Safety note



WARNING

Operating integrated information systems and communication devices during a journey may distract you from the road. You could lose control of the vehicle. There is a risk of accident. Only operate the systems or devices if the traffic conditions allow you to do so. Stop if necessary and operate the systems or devices with the vehicle at a standstill.

Entry and display

Letters and numbers

Depending on the menu, it is possible to enter upper and lower case letters, numbers and characters.

Symbol	Function
abc ABC	To switch between upper and lower case.
	To insert spaces.
	To use the voice control.
OK	To confirm your entry.

Entry comparison

When entering names and addresses, the selection is gradually narrowed down or may be supplemented with every subsequent letter entered.

Inputs are continuously compared with the data saved in the vehicle.

- ▶ Only letters for which data is available are offered for entry.
- ▶ Destination search: place names can be entered in all languages available in iDrive.

Enabling/disabling functions

Some menu items are preceded by a checkbox. The box indicates whether the function is enabled or disabled. Selecting the menu item enables or disables the function.













- Function is enabled.
- Function is disabled.

Status information





General

The status field is located in the top area of the control display. Status information is displayed in the form of symbols.





Symbols for telephone

Symbol	Meaning
	Incoming or outgoing call.
	Missed call.
	Reception level of mobile telephone network.
	Searching for network.
	No mobile telephone network available.
	Mobile telephone charge level is critically low.
	Data transfer not possible.
	Roaming active.
	Text message received.
	Message received.
	Reminder.
	Sending not possible.
	Contacts are being loaded.

Symbols for entertainment

Symbol	Meaning
	CD/DVD drive.
	Bluetooth audio.
	USB device.
	Online Entertainment.
	Apple CarPlay.

Other symbols

Symbol	Meaning
	Check Control message.
	Audio output switched off.
	Encrypted connection not active.
	Current vehicle position.
	Traffic information.

Split screen

General

Additional information, for example information from the on-board computer, can be displayed on the right-hand side of the split screen in some menus.

The additional information remains visible in the split screen even if you switch to a different menu.

Switching on/off

-  Press the button.
- "Split screen"

Selecting the display

The display can be selected in the menus in which a split screen view is possible.

- Tilt the Controller to the right until split screen is selected.
- Press the Controller.
- Select the desired setting.

Selecting the screen content

The screen content can be specified.

- Tilt the Controller to the right until split screen is selected.
- Press the Controller.
- "Personalise menu"

4. Select the desired setting.
5. Tilt the Controller to the left.

Controls

Overview



- 1 Control display, with touchscreen depending on the equipment version
- 2 Controller with buttons

Control display

General

To clean the control display, follow the care instructions, see page 312.

If the control display is exposed to very high temperatures, for example because of strong sunlight, the brightness may be reduced and the control display may even switch itself off. Normal functions will be restored when the temperature is reduced, for example by shading or using the air conditioning system.

Safety note

NOTE

Objects located in front of the control display may slip and damage the control display. There is a risk of material damage. Do not place objects in front of the control display.

Switching on/off automatically

The control display is switched on automatically when the vehicle is unlocked or as soon as the control display is required for operation.

In certain situations, the control display is switched off automatically, for example if no operation is performed on the vehicle for several minutes.

Switching on/off manually

The control display can also be switched off manually.

1.  Press the button.
2. "Switch off control display"

Press the Controller or any button on the Controller to switch it back on again.

Controller with navigation system

General

The buttons can be used to call up menus directly. The Controller can be used to select menu items and perform settings.

Operation

- ▶ Turn to switch between menu items, for example.

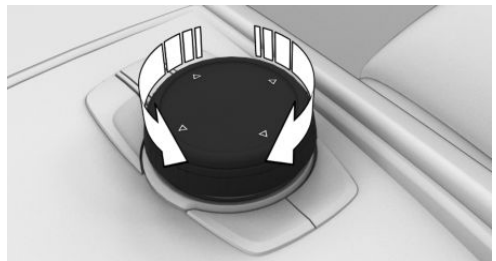



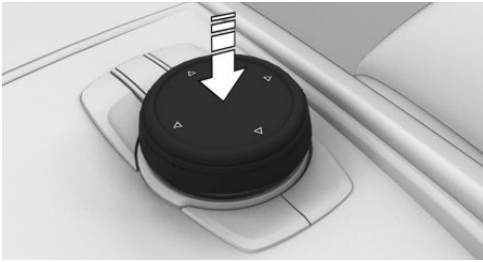

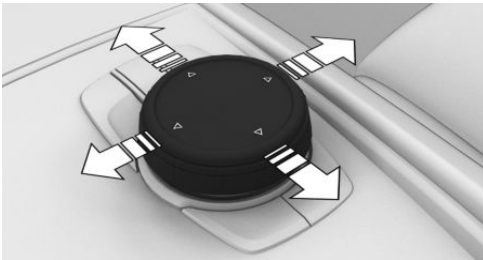

- ▶ Press to select a menu item, for example.



- ▶ Tilt in four directions to switch between screens, for example.



Buttons on the Controller

Button	Function
	Press once: to call up the main menu. Press twice: shows all menu items of the main menu.
	To call up the Communication menu.
	To call up the Media/Radio menu.
	To call up the destination entry menu of the navigation system.
	To call up the navigation map.
	Press once: to call up the previous screen. Press and hold: to call up the recently used menus.
	To call up the Options menu.

Controller without navigation system

General

The buttons can be used to call up menus directly. The Controller can be used to select menu items and perform settings.

Operation

- ▶ Turn to switch between menu items, for example.

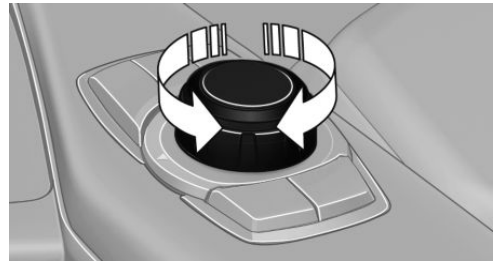



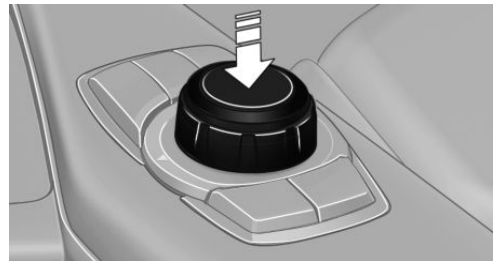

- ▶ Press to select a menu item, for example.

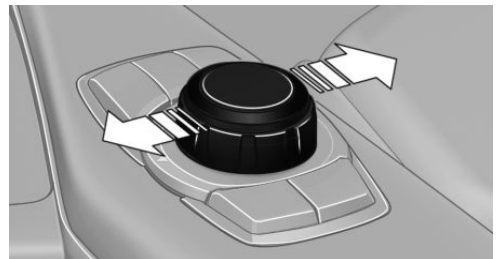

- ▶ Tilt in two directions to switch between screens, for example.



Buttons on the Controller

Button	Function
	Press once: to call up the main menu. Press twice: shows all menu items of the main menu.
	To call up the Communication menu.
	To call up the Media/Radio menu.
	Press once: to call up the previous screen. Press and hold: to call up the recently used menus.
	To call up the Options menu.

Operation using the Controller

Calling up the main menu

 Press the button.

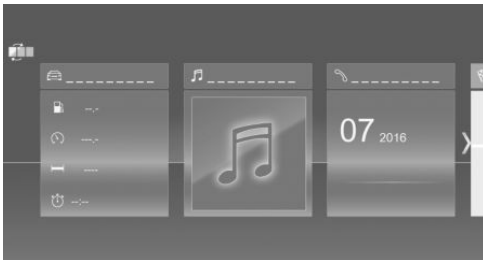

The main menu is displayed.

All iDrive functions can be called up via the main menu.

Adapting the main menu

-  Press the button twice.

All menu items of the main menu are displayed.

- Select a menu item.
- To move a menu item to the desired position, tilt the Controller to the right or left.

Selecting a menu item

Highlighted menu items can be selected.

- Turn the Controller until the desired menu item is highlighted.

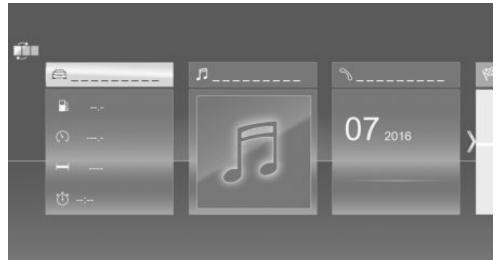

- Press the Controller.

Dynamic content

Dynamic content can be displayed within the menu items. The content in the menu items updates automatically, for example active route guidance in the navigation.

Via iDrive:

- "My Vehicle"
- "Contents of main menu"

Switching between screens

After a menu item has been selected, for example "iDrive settings", a new screen is displayed.

- ▶ Tilt the Controller to the left.

The current screen is closed and the previous screen is displayed.

- ▶  Press the button.

The previous screen is opened again.

- ▶ Tilt the Controller to the right.

The new screen is opened.

An arrow indicates that further screens can be called up.

Calling up recently used menus

 Press and hold the button.

The recently used menus are displayed.

Calling up the Options menu

 Press the button.

The "Options" menu is displayed.

The menu consists of various areas, such as:



- ▶ "Split screen": display settings.
- ▶ "Media/Radio": operating options for the selected main menu.
- ▶ "Save station": if applicable, other operating options for the selected menu.

Entering letters and numbers

Entry

1. Turn the Controller: to select a letter or number.
2. **OK** : to confirm your entry.

Deleting

Symbol	Function
	Press the Controller: to delete a letter or number.
	Press and hold the Controller: to delete all letters or numbers.

Using alphabetical lists

For alphabetical lists with more than 30 entries, the letters for which entries exist can be displayed on the left.

1. Turn the Controller quickly to the left or right.

All the letters for which an entry exists are shown on the left.

2. Select the initial letter of the desired entry. The first entry for the selected letter is displayed.

Operation by touchscreen

General

Depending on the equipment, the control display may be equipped with a touchscreen.

Touch the touchscreen with your fingers. Do not use any objects.

Calling up the main menu

 Tap the symbol.

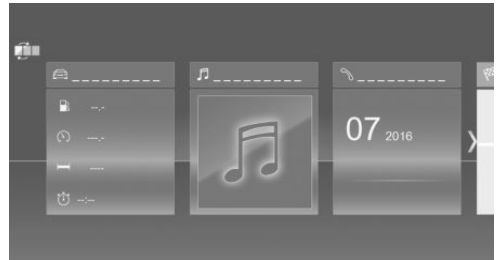

The main menu is displayed.

All iDrive functions can be called up via the main menu.

Adapting the main menu

1.  Tap the symbol. All menu items of the main menu are displayed.
2. Drag the menu item to the desired position on the right or left.

Selecting a menu item

Tap the required menu item.



Dynamic content

Dynamic content can be displayed within the menu items. The content in the menu items updates automatically, for example active route guidance in the navigation.

Via iDrive:

1. "My Vehicle"
2. "Contents of main menu"

Switching between screens

After a menu item has been selected, a new screen is displayed.

An arrow indicates that further screens can be called up.

- ▶ Swipe to the left.
- ▶ Tap the arrow.

The new screen is opened.



Entering letters and numbers

Entry

1.  Tap the symbol on the touchscreen.
A keyboard appears on the control display.
2. Enter the required letters and numbers.

Deleting

Symbol Function

- | | |
|---|--|
|  | Tap the symbol: to delete letter or number. |
|  | Tap and hold the symbol: to delete all letters or numbers. |

Operating the navigation map

The navigation map can be moved via the touchscreen.

Function	Operation
To zoom in/out on the map.	Pinch together or move apart your fingers.



Functional bookmarks

General

iDrive functions, for example radio stations, navigation destinations, telephone numbers and shortcuts to the menu, can be saved to functional bookmarks and called up directly.

The settings are saved for the current driver profile.

Saving a function

1. Select function via iDrive.
2. ... Press and hold the desired button until a signal sounds.

Performing a function

1. ... Press the button.

The function is carried out immediately. If you have selected a telephone number for example, the connection will also be established.

Displaying the button assignment

Touch the buttons with your finger. Do not wear gloves or use objects.

The button assignment is displayed in the upper area of the control display.

Clearing the button assignment

1. Press and hold buttons 1 and 8 simultaneously for approximately 5 seconds.
2. "OK"

Voice control system

Vehicle equipment

This chapter describes all standard, country-specific and optional equipment available for the model series. It may therefore describe equipment and functions which are not installed in your vehicle, for example on account of the optional equipment selected or the national-market version. This also applies to safety-relevant functions and systems. Please comply with the relevant laws and regulations when using the corresponding functions and systems.

Principle

Most functions displayed on the control display can also be controlled by spoken commands using the voice control system. The system provides spoken announcements to assist you with input.

General

- ▶ Functions that can only be used when the vehicle is stationary can only be operated via the voice control system to a limited extent.
- ▶ The system has a special microphone on the driver's side.
- ▶ ›...‹ in the Owner's Handbook indicates commands for the voice control system.

Operating requirements

- ▶ A language must be set using iDrive that is supported by the voice control system. To select the language, see page 48.
- ▶ Always say the commands in the language of the voice control system.

Saying voice commands

Activating the voice control system

1.  Press the button on the steering wheel.
2. Wait for the acoustic signal.
3. Say the command.



This symbol indicates that the voice control system is active.

It's possible that there may be no further spoken commands available for the selected function. In this case, switch to iDrive to operate the function.

Switching off the voice control system



Press the button on the steering wheel or say ›Cancel‹.

Possible commands

General

Most of the menu items on the control display can be said as commands.

Commands from other menus can also be spoken.

Some list entries, for example telephone book entries, can also be selected using the voice control system. When doing so, say the list entries exactly as they are shown in the relevant list.

Displaying possible commands

The following is displayed in the upper area of the control display:

- ▶ Some of the possible commands for the current menu.
- ▶ Some of the possible commands from other menus.
- ▶ Voice recognition status.
- ▶  Encrypted connection unavailable.

An example: calling up sound settings

Commands for the menu items are spoken exactly as they are selected using the Controller.

1. If necessary, switch on entertainment audio output.
2.  Press the button on the steering wheel.
3. ›Media and radio‹
4. ›Sound‹

Help with the voice control system

- ▶ ›Help with voice input‹: to have information about the voice control system read aloud.
- ▶ ›Help‹: to have help on the current menu read aloud.

Information for emergency calls

The voice control system should not be used for emergency calls. Under stress, a person's speech and voice pitch can change. This could unnecessarily delay connection of your call.

Instead, use the SOS button, see page 301, located near the interior mirror.

Settings

Selecting the speech dialogue

You can select whether the system uses the standard dialogue or the short variant.

If the short variant is selected, the system announcements are played in shortened form.

Via iDrive:

1. "My Vehicle"
2. "iDrive settings"
3. "Language"
4. "Voice control:"
5. Select the desired setting.

Speaking during voice output

It is possible to answer while the voice control system is querying your previous spoken instruction. The function can be deactivated if the queries are frequently cancelled inadvertently, for example due to background noise or conversations in the vehicle.

Via iDrive:

1. "My Vehicle"
2. "iDrive settings"
3. "Language"
4. "Speaking during voice output"

Online speech processing

Online speech processing enables use of the dictation function, facilitates the natural input of destinations and improves the quality of voice recognition. To use the function, data is sent across an encrypted connection to a service provider where it is then stored.

Via iDrive:

1. "My Vehicle"
2. "iDrive settings"
3. "Language"
4. "Server speech recognition"

Adjusting the volume

Turn the volume knob during the spoken instructions until the desired volume is obtained.

- ▷ The volume setting is retained even if you change the volume of other audio sources.
- ▷ The volume setting is saved for the current driver profile.



System limits

- ▷ Certain noises may be detected and could result in problems. Keep doors, windows and the glass sunroof closed.
- ▷ Noise from the front passenger or rear seat occupants may interfere with the system. Avoid background noise in the vehicle while you are speaking.
- ▷ Strong dialects may prevent voice recognition from working properly. Speak loudly and clearly.

Using the voice control system on the smartphone

A smartphone connected to the vehicle can be operated via voice control.

This requires voice control to be activated on the smartphone.

1.  Press and hold the button on the steering wheel for approx. 3 seconds. Voice control on the smartphone is activated.
2.  Release the button.
If activation is successful, a confirmation appears on the control display.

If it was not possible to activate voice control, the list of Bluetooth devices appears on the control display.

Voice assistants from third-party providers

Principle

Various digital voice assistants are available from third-party providers. Supported voice assistants can be used in the vehicle.

General

Some functions may only work to a limited extent in the vehicle to ensure they do not create a safety risk when driving.

Operating requirements

- ▷ Connected Voice Services acquired via the ConnectedDrive Store.
- ▷ The same ConnectedDrive account is used in the vehicle and in the BMW Connected app.
- ▷ Vehicle added in the BMW Connected app.
- ▷ Third-party provider account and BMW account linked in the BMW Connected app.
- ▷ Smartphone connected to the vehicle via Bluetooth.

Activation in the BMW Connected app

Systems from third-party providers are set up in the BMW Connected app.

Follow the instructions in the app.

Activation in the vehicle

Authorisation to use the voice assistant is required before the start of each journey.

1. To authorise voice assistants from third-party providers:
 - ▷ Connect the smartphone to the vehicle via Bluetooth.

- ▶ Select the appropriate driver profile, see page 74.
- 2.  Press the button on the steering wheel.
- 3. Wait for the acoustic signal.
- 4. Say the specific activation word from the third-party provider and the required command.

Information about the active function appears on the control display.

Malfunction

In the event of a malfunction, switch the engine off and on again.

General settings

Vehicle equipment

This chapter describes all standard, country-specific and optional equipment available for the model series. It may therefore describe equipment and functions which are not installed in your vehicle, for example on account of the optional equipment selected or the national-market version. This also applies to safety-relevant functions and systems. Please comply with the relevant laws and regulations when using the corresponding functions and systems.

Language

Selecting the language

Via iDrive:

1. "My Vehicle"
2. "iDrive settings"
3. If necessary, "Language"
4. "Language:"
5. Select the desired setting.

The setting is saved for the current driver profile.

Time

Setting the time zone

Via iDrive:

1. "My Vehicle"
2. "iDrive settings"
3. "Date and time"
4. "Time zone:"
5. Select the desired setting.

The setting is saved for the current driver profile.

Setting the time

Via iDrive:

1. "My Vehicle"
2. "iDrive settings"
3. "Date and time"
4. "Time:"
5. Turn the Controller until the desired hours are displayed.
6. Press the Controller.
7. Turn the Controller until the desired minutes are displayed.
8. Press the Controller.

Setting the time format

Via iDrive:

1. "My Vehicle"
2. "iDrive settings"
3. "Date and time"
4. "Time format:"
5. Select the desired setting.

The setting is saved for the current driver profile.

Automatic time setting

Depending on the equipment, the time, date and, if necessary, time zone are updated automatically.

Via iDrive:

1. "My Vehicle"
2. "iDrive settings"
3. "Date and time"
4. "Automatic time setting"

The setting is saved for the current driver profile.

Date

Setting the date

Via iDrive:

1. "My Vehicle"
2. "iDrive settings"
3. "Date and time"
4. "Date:"
5. Turn the Controller until the desired day is displayed.
6. Press the Controller.
7. Select the month and year.

Setting the date format

Via iDrive:

1. "My Vehicle"
2. "iDrive settings"
3. "Date and time"
4. "Date format:"
5. Select the desired setting.

The setting is saved for the current driver profile.

Selecting the units of measurement

It is possible to select the units of measurement for various values, for example consumption, distances and temperature.

Via iDrive:

1. "My Vehicle"
2. "iDrive settings"
3. "Units"
4. Select the desired menu item.
5. Select the desired setting.

The setting is saved for the current driver profile.

Activating/deactivating display of the current vehicle position

Principle

If vehicle tracking is activated, the current vehicle position can be displayed in the BMW Connected app or in the ConnectedDrive customer portal.

Activating/deactivating

Via iDrive:

1. "My Vehicle"
2. "Vehicle settings"
3. "Data privacy"
4. "Vehicle tracking"
5. Select the desired setting.

Activating/deactivating pop-ups

Pop-ups are automatically shown on the control display for some functions. Some of these pop-ups can be activated or deactivated.

Via iDrive:

1. "My Vehicle"
2. "iDrive settings"
3. "Pop-ups"
4. Select the desired setting.

The setting is saved for the current driver profile.

Control display

Brightness

Via iDrive:

1. "My Vehicle"
2. "iDrive settings"
3. "Displays"
4. "Control display"
5. "Brightness at night"
6. Turn the Controller until the desired brightness is obtained.
7. Press the Controller.

The setting is saved for the current driver profile.

Depending on the lighting conditions, the brightness adjustment may not be immediately apparent.

Screen saver

If no entries were made via iDrive, the screensaver can be displayed after a set time.

Via iDrive:

1. "My Vehicle"
2. "iDrive settings"
3. "Displays"
4. "Control display"
5. "Screensaver"
6. Select the desired setting.

The setting is saved for the current driver profile.

Selecting the content of the main menu

The content displayed in some menu items of the main menu can be selected.

1.  Press the button.
2. "Contents of main menu"
3. Select the desired menu and desired content.

The setting is saved for the current driver profile.

Notifications

Principle

The menu shows all messages received by the vehicle, centrally in the form of a list.

General

The following messages can be displayed:

- ▶ Traffic messages.
- ▶ Communication messages, for example e-mail, SMS or reminders.
- ▶ Messages from the Concierge Service or the BMW Connected app, for example.
- ▶ Check Control messages.
- ▶ Service requirement messages.
- ▶ Messages from the vehicle manufacturer.

Notifications are additionally displayed in the status field.

Calling up notifications

Via iDrive:

1. "Notifications"
2. Select the required notification.

The menu in which the notification is displayed is opened.

Deleting notifications

All notifications which are not Check Control messages or messages from the vehicle manufacturer can be deleted from the list.

Check Control messages or messages from the vehicle manufacturer remain for as long as they are relevant.

Via iDrive:

1. "Notifications"
2. Select the required notification if necessary.

3.  Press the button.
4. "Delete this notification" or "Delete all notifications"

Settings

The following settings can be performed:

- ▷ Selection of applications from which notifications are allowed.
- ▷ Sort notifications by date or priority.

Via iDrive:

1. "My Vehicle"
2. "iDrive settings"
3. "Notifications"
4. Select the desired setting.

Data protection

Data transfer

Principle

The vehicle offers various functions whose use requires data to be transferred to BMW or a service provider. The transfer of data can be deactivated for some functions.

General

If data transfer has been deactivated for a function, then that function cannot be used.

Only perform settings with the vehicle at a standstill.

Activating/deactivating

Follow the instructions on the control display.

Via iDrive:

1. "My Vehicle"
2. "iDrive settings"
3. "Data privacy"
4. Select the desired setting.

Deleting personal data in the vehicle

Principle

Depending on use, the vehicle stores personal data such as saved radio stations. This personal data can be permanently deleted using iDrive.

General

Depending on the equipment in your vehicle, the following data can be deleted:

- ▷ Driver profile settings.
- ▷ Saved radio stations.
- ▷ Saved functional bookmarks.
- ▷ Trip and on-board computer values.
- ▷ Music hard disc.
- ▷ Navigation, for example saved destinations.
- ▷ Phone book.
- ▷ Online data, for example Favourites, cookies.
- ▷ Office data, for example voice memos.
- ▷ Login accounts.

It may take up to 15 minutes in total to delete data.

Operating requirements

Data can only be deleted with the vehicle at a standstill.

Deleting data

Follow the instructions on the control display.

Via iDrive:

1. "My Vehicle"
2. "iDrive settings"
3. "Data privacy"
4. "Delete personal data"
5. "Delete personal data"
6. "OK"
7. Exit and lock the vehicle.

It takes 15 minutes to complete the deletion process.

If not all data is deleted, repeat the deletion process if required.

Cancelling deletion

Start the engine to cancel data deletion.

Connections

Principle

The vehicle offers various types of connections for using mobile devices. Which connection type to select depends on the mobile device and the function you wish to use.

General

The following list shows possible functions and the appropriate connection types for them. The level of functionality depends on the mobile device.

Function	Connection type
Making calls using the hands-free system.	Bluetooth.
Operating telephone functions via iDrive.	
Using the smartphone Office functions.	
Playing music from a smartphone or audio player.	Bluetooth or USB.
Operating compatible apps via iDrive.	Bluetooth or USB.

Function	Connection type
USB storage medium:	USB.
Exporting and importing driver profiles.	
Performing software updates.	
Importing and exporting stored journeys.	
Playing music.	
Playing videos from a smartphone or USB device.	USB.
Operate Apple CarPlay apps via iDrive and by voice commands.	Bluetooth and WLAN.

The following connection types require one-off pairing with the vehicle:

- ▷ Bluetooth.
- ▷ Apple CarPlay.

Paired devices are then automatically recognised and connected to the vehicle.

Safety note

WARNING

Operating integrated information systems and communication devices during a journey may distract you from the road. You could lose control of the vehicle. There is a risk of accident. Only operate the systems or devices if the traffic conditions allow you to do so. Stop if necessary and operate the systems or devices with the vehicle at a standstill.

Compatible devices

General

Information about mobile devices compatible with the vehicle is available at www.bmw.com/bluetooth.

Malfunctions may occur when using unlisted devices or different software versions.

Viewing the vehicle identification number and software part number

When looking for compatible devices, the vehicle identification number and software part number may have to be stated. These numbers can be displayed in the vehicle.

Via iDrive:

1. "My Vehicle"
2. "iDrive settings"
3. "Mobile devices"
4. "Settings"
5. "Bluetooth information"
6. "System information"

You have the option of performing a software update, see page 58.

Bluetooth connection

Operating requirements

- ▶ Compatible device with Bluetooth interface, see page 52.
- ▶ The vehicle key is in the vehicle.
- ▶ The device is operational.
- ▶ Bluetooth is activated on the device and in the vehicle, see page 53.
- ▶ The device may require certain Bluetooth default settings, for example visibility; see the operating instructions of the device.

Switching on Bluetooth

Via iDrive:

1. "My Vehicle"
2. "iDrive settings"
3. "Mobile devices"
4. "Settings"
5. "Bluetooth"

Enabling/disabling telephone functions

To be able to use all supported functions of a mobile telephone, the following functions need to be activated prior to pairing:

Via iDrive:

1. "My Vehicle"
2. "iDrive settings"
3. "Mobile devices"
4. "Settings"
5. Select the desired setting; for example:
 - ▶ "Office"





Activate this function to transfer SMS messages, e-mails, calendar, tasks, memos and reminders to the vehicle. Transferring all data to the vehicle may incur costs.
 - ▶ "Contact pictures"

Activate this function to have contact pictures displayed.
 - ▶ "Apple CarPlay"

Activate the function to use Apple CarPlay.

Pairing the mobile device with the vehicle

Via iDrive:

1. "My Vehicle"
2. "iDrive settings"
3. "Mobile devices"
4. "Connect new device"
5. Select the functions for which the device will be used:
 - ▶  "Telephone"
 - ▶  "Bluetooth audio"
 - ▶  "Apps"
 - ▶  "Apple CarPlay"

The Bluetooth name of the vehicle is shown on the control display.

6. On the mobile device, search for Bluetooth devices in the vicinity.

The vehicle's Bluetooth name is shown on the display of the mobile device.

Select the vehicle's Bluetooth name.

7. Depending on the mobile device, either a control number is displayed, or you will have to enter the control number yourself.

- ▶ Compare the control number shown on the control display with the control number on the device display.

Confirm the control number on the device and on the control display.

- ▶ Enter the same control number on the device and via iDrive then confirm.

The device is connected and displayed in the device list, see page 56.

If the connection was not successful: Frequently Asked Questions, see page 54.

Frequently Asked Questions

For the mobile device to work correctly, all pre-conditions have to be met and all the necessary steps have to be carried out in the correct order. Even when this is done, however, there may still be instances where the mobile device does not function as expected.

In such cases, the following explanations may provide assistance:

Why could the mobile telephone not be paired or connected?

- ▶ Too many Bluetooth devices are paired to the mobile telephone or the vehicle.

In the vehicle, delete Bluetooth connections with other devices.

Delete all known Bluetooth connections from the device list on the mobile telephone and start a new device search.

- ▶ The mobile telephone is in power-save mode or the battery is low.

Charge the mobile telephone.

Why does the mobile telephone no longer respond?

- ▶ The applications on the mobile telephone are no longer functioning.

Switch the mobile telephone off and on again.

- ▶ Ambient temperatures too high or too low to operate the mobile telephone.

Do not subject the mobile telephone to extreme ambient conditions.

Why can telephone functions not be operated via iDrive?

- ▶ The mobile telephone may not be configured correctly, for example as a Bluetooth audio device.

Connect the mobile telephone with the telephone or additional telephone function.

Why are no phone book entries, not all entries or incomplete entries being displayed?

- ▶ The transfer of the phone book entries is not yet completed.

- ▶ Under certain circumstances only the phone book entries saved in the mobile telephone or on the SIM card are transferred.

- ▶ It may not be possible to display phone book entries containing special characters.

- ▶ It may not be possible to transfer contacts from social networks.

- ▶ The number of phone book entries to be saved is too high.

- ▶ The volume of data for a particular contact is too large, for example due to saved information such as memos.

Reduce the data volume for the contact.

- ▶ A mobile telephone can only be connected as an audio source or as a telephone.

Configure the mobile telephone and connect it with the telephone or additional telephone function.

How can the telephone connection quality be improved?

- ▷ Depending on the mobile telephone, it may be possible to adjust the strength of the Bluetooth signal on the mobile telephone.
- ▷ Place the mobile telephone in the snap-in adapter or close to the centre console.
- ▷ Insert the mobile telephone in the wireless charging dock.
- ▷ Adjust the volume of the microphone and loudspeakers separately.

If all the points on the list have been reviewed and the desired function cannot be performed, contact the Hotline, a Service Partner of the manufacturer or another qualified Service Partner or a specialist workshop.

USB connection

General

The following mobile devices can be connected to the USB port:

- ▷ Mobile telephones.
 - The snap-in adapter has its own USB port that is automatically connected when an appropriate mobile telephone is inserted.
- ▷ Audio devices with a USB port, for example MP3 players.
- ▷ USB storage devices.
 - Common file systems are supported. Formats FAT32 and exFAT are recommended.

A connected USB device is charged via the USB port if the device supports this. Note the maximum charge current of the USB port.

The following can be done at USB ports supporting data transfer:

- ▷ Exporting and importing of driver profiles, see page 74.
- ▷ Playback of music files via USB audio.
- ▷ Playback of video films via USB video.
- ▷ Importing of software updates, see page 58.

When connecting, bear the following in mind:

- ▷ Do not use force when inserting the connector into the USB port.
- ▷ Use a flexible adapter cable.
- ▷ Protect the USB device from mechanical damage.
- ▷ Due to the large variety of USB devices available on the market, it is not possible to guarantee that every device can be operated via the vehicle.
- ▷ Do not expose the USB devices to extreme environmental conditions, for example very high temperatures; see the operating instructions of the device.
- ▷ Due to the large variety of different compression techniques, correct playback of the media stored on the USB device cannot be guaranteed in every case.
- ▷ To ensure correct transmission of the stored data, do not charge a USB device from the 12 V power socket in the vehicle when the device is also connected to the USB port.
- ▷ Depending on how the USB device is being used, settings may need to be performed on the USB device; see the operating instructions of the device.

Unsuitable USB devices:

- ▷ USB hard drives.
- ▷ USB hubs.
- ▷ USB memory card reader with several slots.
- ▷ HFS-formatted USB devices.
- ▷ Devices such as fans or lamps.

Operating requirements

Compatible device with USB port, see page 52.

Connecting a device

Connect the USB device to a USB port, see page 212, using a suitable adapter cable.

The USB device is displayed in the device list, see page 56.

Apple CarPlay preparation

Principle

CarPlay makes it possible to operate certain functions of a compatible Apple iPhone by Siri voice operation and using iDrive.

Operating requirements

- ▷ Compatible iPhone, see page 52.
iPhone 5 or later with iOS 7.1 or later.
- ▷ Appropriate mobile radio contract.
- ▷ Bluetooth, WLAN and Siri voice operation are activated on the iPhone.
- ▷ The setting for mobile data may need to be activated on the iPhone.
- ▷ Booking of the ConnectedDrive service: Apple CarPlay preparation.

Switching on Bluetooth and CarPlay

Via iDrive:

1. "My Vehicle"
2. "iDrive settings"
3. "Mobile devices"
4. "Settings"
5. Select the following settings:
 - ▷ "Bluetooth"
 - ▷ "Apple CarPlay"

Pairing the iPhone with CarPlay

Pair the iPhone with the vehicle via Bluetooth, see page 53.

Select CarPlay as the function:

- Ⓞ "Apple CarPlay"

The iPhone is connected to the vehicle and displayed in the device list, see page 56.

Operation

For further information, see the integrated Owner's Handbook or the Owner's Handbook for Navigation, Entertainment and Communication.

Frequently Asked Questions

For the mobile device to work correctly, all pre-conditions have to be met and all the necessary steps have to be carried out in the correct order. Even when this is done, however, there may still be instances where the mobile device does not function as expected.

In such cases, the following explanations may provide assistance:

The iPhone has already been paired with Apple CarPlay. When a new connection is established, CarPlay can no longer be selected.

- ▷ Delete the iPhone concerned from the device list.
- ▷ On the iPhone, delete the vehicle concerned from the list of saved vehicles under Bluetooth and under WLAN.
- ▷ Pair the iPhone as a new device.

If the steps listed have been carried out and the desired function still cannot be run: contact the hotline, a Service Partner of the manufacturer, another qualified Service Partner or a specialist workshop.

Managing mobile devices

General

- ▷ Following one-off pairing, the devices are automatically detected and connected again when the ignition is switched on.
- ▷ Once the device has been detected, the data saved on the SIM card or in the mobile telephone is transferred to the vehicle.
- ▷ In some devices, certain settings may be necessary, for example authorisation; see the operating instructions of the device.

Displaying the device list





All devices paired or connected to the vehicle are displayed in the device list.

Via iDrive:

1. "My Vehicle"

2. "iDrive settings"
3. "Mobile devices"

A symbol indicates which function a device is used for.

Symbol	Function
	"Telephone"
	"Additional telephone"
	"Bluetooth audio"
	"Apps"
	"Apple CarPlay"

Configuring the device

Functions can be activated or deactivated on a paired or connected device.

Via iDrive:

1. "My Vehicle"
2. "iDrive settings"
3. "Mobile devices"
4. Select the required device.
5. Select the desired setting.

When a function is assigned to a device, where necessary it is disabled on a device that is already connected and that device is disconnected.

Disconnecting a device

A device's connection to the vehicle is disconnected.

The device remains paired and can be connected again, see page 57.

Via iDrive:

1. "My Vehicle"
2. "iDrive settings"
3. "Mobile devices"
4. Select a device.
5. "Disconnect device"

Connecting a device

A disconnected device can be reconnected.

Via iDrive:

1. "My Vehicle"
2. "iDrive settings"
3. "Mobile devices"
4. Select a device.
5. "Connect device"

Functions assigned to the device before disconnection are reassigned to the device upon reconnection. If applicable, these functions are deactivated for an already connected device.

Deleting a device

Via iDrive:

1. "My Vehicle"
2. "iDrive settings"
3. "Mobile devices"
4. Select a device.
5. "Delete device"

The device is disconnected and deleted from the device list.

Swapping the telephone and additional telephone

If two mobile telephones are connected with the vehicle, the functions of the telephone and additional telephone can be swapped.

Via iDrive:

1. "My Vehicle"
2. "iDrive settings"
3. "Mobile devices"
4. "Settings"
5. "Swap telephone/additional tel."

Software update

General

The vehicle supports a large number of mobile devices, for example mobile telephones and MP3 players. Software updates are provided for many of the supported devices. Regular updating of the vehicle software keeps the vehicle up to date.

Updates and related, up-to-date information are posted on the website at www.bmw.com/update.

Displaying the version of the installed software

The version of the software installed in the vehicle is displayed.

Via iDrive:

1. "My Vehicle"
2. "iDrive settings"
3. "Software update"
4. "Show current version"

If an update has already been applied, select the desired version to show additional information.

Updating software via USB

Do not attempt to update the software unless the vehicle is at a standstill.

Via iDrive:

1. Save the software update file onto a USB device in the main folder.
2. Connect the USB stick to a USB port, see page 212.
3. "My Vehicle"
4. "iDrive settings"
5. "Software update"
6. "Update software"
7. "USB"
8. "Install software"
9. "OK"

10. Wait for the update.

11. Confirm the system restart.

Restoring a previous software version

It is possible to restore the software to the version prior to the last update or to its factory settings.

Do not attempt to restore the software unless the vehicle is at a standstill.

Via iDrive:

1. "My Vehicle"
2. "iDrive settings"
3. "Software update"
4. "Restore software"
5. ▶ "Previous version"
 - The previous software version is restored.
 - ▶ "Software factory settings"
 - The first software version is restored.
6. "Remove software"
7. "OK"
8. Wait for restore.
9. Confirm the system restart.

Owner's Handbook media

Vehicle equipment

This chapter describes all standard, country-specific and optional equipment available for the model series. It may therefore describe equipment and functions which are not installed in your vehicle, for example on account of the optional equipment selected or the national-market version. This also applies to safety-relevant functions and systems. Please comply with the relevant laws and regulations when using the corresponding functions and systems.

General

The contents of the Owner's Handbook can be accessed in various ways.

- ▶ Printed Owner's Handbook, see page 59.
- ▶ Integrated Owner's Handbook in the vehicle, see page 59.

Printed Owner's Handbook

Principle

The printed Owner's Handbook describes all standard, country-specific and optional equipment available for the model series.

General

The Owner's Handbook for Navigation, Entertainment and Communication is available as a printed book from Service.

Supplementary Owner's Handbooks

Please also follow the Supplementary Owner's Handbooks which are provided along with the on-board literature as required.

Integrated Owner's Handbook in the vehicle

Principle

The integrated Owner's Handbook describes the specific equipment and functions present in the vehicle. The integrated Owner's Handbook can be shown on the control display.

Selecting the Owner's Handbook

1.  Press the button.
2. "My Vehicle"
3. "Owner's Handbook"
4. Select the required method of accessing the contents.

Scrolling within the Owner's Handbook

Turn the Controller until the next or previous contents are displayed.

Context-sensitive help

General

The section of the Owner's Handbook relating to the function that is currently selected can be displayed directly.

Calling up when using iDrive

To switch from the function on the control display directly to the Options menu:

1.  Press the button.
2. "Owner's Handbook"



Calling up when a Check Control message is displayed

To switch directly from the Check Control message on the control display:

 "Owner's Handbook"

Switching between a function and the Owner's Handbook

To switch from a function on the control display, for example the radio, to the Owner's Handbook and to toggle between the two displays:

1.  Press the button.
2. "Owner's Handbook"
3. Select the desired page in the Owner's Handbook.
4.  Press the button again to switch back to the last displayed function.
5.  Press the button again to switch back to the last displayed page of the Owner's Handbook.

To switch continuously between the last displayed function and the last displayed page of the Owner's Handbook, repeat steps 4 and 5. New screens are opened each time you do so.

Opening and closing

Vehicle equipment

This chapter describes all standard, country-specific and optional equipment available for the model series. It may therefore describe equipment and functions which are not installed in your vehicle, for example on account of the optional equipment selected or the national-market version. This also applies to safety-relevant functions and systems. Please comply with the relevant laws and regulations when using the corresponding functions and systems.

Vehicle key

General

The delivery specification includes two vehicle keys with integrated keys.

Each vehicle key contains a replaceable battery, see page 65.

Various settings, see page 76, are possible for the button functions, depending on the equipment and the national-market version.

A personal driver profile, see page 74, for each vehicle key is saved in the vehicle.

To provide information on maintenance requirements, the service data is saved in the vehicle key, see page 287.

To prevent the vehicle key from being locked in, take it with you whenever you leave the vehicle.

Safety notes

WARNING

The vehicle key has a button cell battery. Batteries or button cells can be swallowed and lead to serious or fatal injuries within two hours, for example due to internal burns or chemical

burns. There is a danger of injury or danger to life. Keep the vehicle key and batteries out of reach of children. Immediately seek medical help if there is any suspicion that a battery or button cell has been swallowed or is located in any part of the body.

WARNING

Persons remaining in the vehicle or pets left inside can lock the doors from the inside and lock themselves in. In this case, the vehicle cannot be opened from the outside. There is a danger of injury. Carry the vehicle key with you so that you can open the vehicle from the outside.

WARNING

On some national-market versions, it is not possible to unlock the vehicle from the inside if it has been locked from the outside.

There is a risk of injury or danger to life if persons remain in the vehicle for extended periods and are exposed to extreme temperatures as a result. Do not lock the vehicle from the outside when there is someone inside it.

WARNING

Unsupervised children or pets in the vehicle can set the vehicle in motion and endanger themselves or other road users, for example by the following actions:

- ▷ Pressing the Start/Stop button.
- ▷ Releasing the parking brake.
- ▷ Opening and closing doors or windows.
- ▷ Engaging selector lever position N.
- ▷ Operating vehicle equipment.

There is a risk of accident or injury. Do not leave children or pets unsupervised in the vehicle. When leaving the vehicle, take the vehicle key with you and lock the vehicle.

Overview

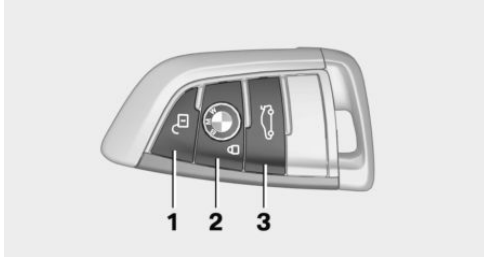

- 1 To unlock
- 2 To lock
- 3 To unlock the tailgate
With automatic tailgate operation: to open/
close the tailgate

Unlocking



Press the button on the vehicle key.

Depending on the settings, see page 76, the following access points are unlocked:

- ▷ The driver's door and the fuel tank filler flap.
Press the button on the vehicle key again to unlock the other vehicle access points.
- ▷ All doors, the tailgate and the fuel tank filler flap.

The following functions are also carried out:

- ▷ Unlocking is acknowledged by the turn indicators. This function needs to be activated in the settings, see page 76.
- ▷ The settings saved in the driver profile, see page 74, are applied.
- ▷ The driver's seat is adjusted to the last seat position saved in the driver's profile. This

function needs to be activated in the settings, see page 76.

- ▷ The interior light, see page 150, is switched on, unless it was switched off manually.
- ▷ Depending on the settings, the welcome light and home lights, see page 146, are switched on.
- ▷ Exterior mirrors which were folded in via the comfort closing feature are folded out.
- ▷ With anti-theft security system: The anti-theft security system is switched off.
- ▷ The alarm system, see page 78, is switched off.

The lighting functions may depend on the ambient brightness.

Comfort opening



Keep the button on the vehicle key pressed after unlocking.

The windows and the glass sunroof are opened for as long as the button on the vehicle key is pressed.

Locking

1. Close the driver's door.
2.  Press the button on the vehicle key.

The following functions are carried out:

- ▷ All doors, the tailgate and the fuel tank filler flap are locked.
- ▷ Locking is acknowledged by the turn indicators. This function needs to be activated in the settings, see page 76.
- ▷ With anti-theft security system: The anti-theft security system is switched on. This prevents the doors from being unlocked using the locking buttons or the door handles.
- ▷ The alarm system, see page 78, is switched on.

If vehicle horn sounds twice when locking, this means engine or ignition is still switched on. In

this case, switch off the engine or the ignition using the Start/Stop button.

Comfort closing

Safety note

WARNING

Parts of the body can become trapped when the comfort closing feature is operated. There is a danger of injury. When the comfort closing feature is operating, make sure that the area of movement is kept clear.

Closing



Keep the button on the vehicle key pressed after locking.

The windows and the glass sunroof are closed for as long as the button on the vehicle key is pressed.

The exterior mirrors are folded in.

If the hazard warning lights are switched on, the exterior mirrors are not folded in.

Switching on the interior light and ground lighting



With the vehicle locked, press the button on the vehicle key.

This function is not available if the interior light was switched off manually.

The lighting functions may depend on the ambient brightness.

After locking, wait 10 seconds before pressing the button again.

Tailgate

General

To prevent the vehicle key from being locked in, do not place it in the luggage compartment.

Depending on the equipment and the national-market version, it is possible to select whether the tailgate can be unlocked with the vehicle key and how the vehicle doors respond. To adjust the settings, see page 76.

On some equipment versions, the doors are also unlocked each time.

Safety notes

WARNING

Parts of the body can become trapped when the tailgate is operated. There is a danger of injury. When opening and closing, make sure that the area of movement of the tailgate is kept clear.

WARNING

The tailgate swings outwards when opened. There is a risk of injury or material damage. When opening and closing, make sure that the area of movement of the tailgate is kept clear.

NOTE

Pointed or angular objects can strike the windows and the heating conductors during the journey. There is a risk of material damage. Cover edges and make sure that pointed objects cannot strike the windows.

Opening



Press the button on the vehicle key for approximately 1 second.

Without automatic tailgate operation:

The tailgate is unlocked and can be opened upwards.

With automatic tailgate operation:

The tailgate is opened automatically.

With automatic tailgate operation: closing



Press and hold the button on the vehicle key until the tailgate has closed.

Releasing the button stops the movement.

Replacing the battery

NOTE

Improper batteries in the vehicle key can damage the vehicle key. There is a risk of material damage. Always replace the discharged battery with a battery with the same voltage, the same size and the same specification.

1. Remove the integrated key from the vehicle key, see page 67.
2. Position the integrated key under the battery compartment lid, arrow 1, and pry off the lid with a lever movement of the integrated key, arrow 2.

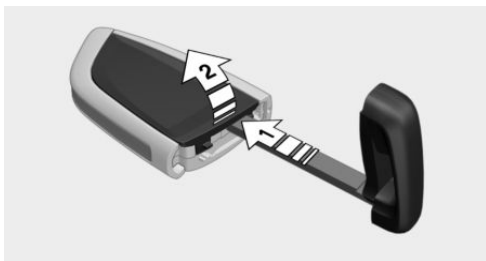

3. Use a pointed object to press the battery in the direction of the arrow and lift it out.

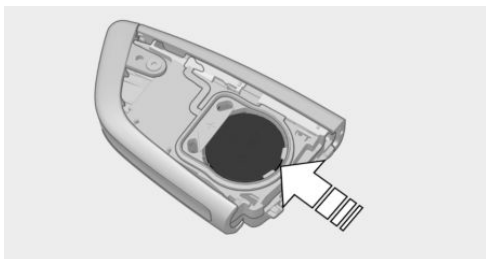

4. Insert a type CR 2032 3 V battery with the positive side facing up.
5. Press the cover back into position and close it.
6. Insert the integrated key into the vehicle key until it engages.



Dispose of old batteries at a Service Partner of the manufacturer or another qualified Service Partner or a specialist workshop or hand them in to an authorised collecting point.

Additional vehicle keys

Additional vehicle keys are available from a Service Partner of the manufacturer or another qualified Service Partner or an authorised workshop.

Loss of vehicle keys

A lost vehicle key can be disabled and replaced by a Service Partner of the manufacturer or another qualified Service Partner or an authorised workshop.

Malfunction

General

A Check Control message is shown.

It may be difficult for the vehicle to detect the vehicle key in some conditions, including the following:

- ▷ The battery of the vehicle key is discharged. To replace the battery, see page 65.
- ▷ Disruption of the radio link by transmission masts or other equipment transmitting powerful signals.
- ▷ Shielding of the vehicle key by metallic objects.

Do not transport the vehicle key together with metallic objects.

- ▷ Disruption of the radio link by mobile telephones or other electronic devices in the immediate vicinity of the vehicle key.

Do not transport the vehicle key together with electronic devices.

- ▷ Interference with the radio transmission caused by the charging of mobile devices, for example a mobile phone.
- ▷ The vehicle key is located in the immediate vicinity of the wireless charging dock.

Place the vehicle key somewhere else.

If there is a malfunction, the vehicle can be unlocked and locked from the outside with the integrated key, see page 66.

Starting the engine via emergency detection of the vehicle key

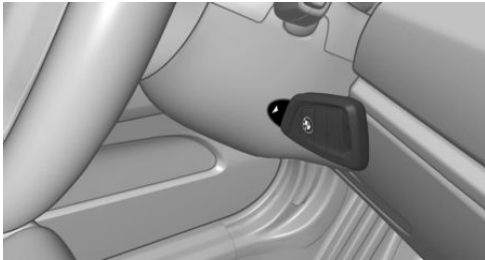

The engine cannot be started if the vehicle key has not been detected.

If this happens, proceed as follows:

1. Hold the tip of the vehicle key against the mark on the steering column. Pay attention to the display in the instrument cluster.
2. If the vehicle key is detected:

Start the engine within 10 seconds.

If the vehicle key is not detected, change the position of the vehicle key slightly and repeat the procedure.

Frequently Asked Questions

What provisions can be made to enable a vehicle to be opened if the vehicle key has accidentally been locked inside the vehicle?

- ▷ The Remote Services of the BMW app can be used to lock and unlock a vehicle.

This requires an active BMW ConnectedDrive contract and the BMW app must be installed on a smartphone.

- ▷ Unlocking of the vehicle can be requested via the BMW ConnectedDrive call centre.

This requires an active BMW ConnectedDrive contract.

Integrated key

General

The integrated key enables the driver's door to be unlocked and locked without the vehicle key.

Use the integrated key to operate the key switch for front passenger airbags, see page 154.

Safety notes

⚠ WARNING

On some national-market versions, it is not possible to unlock the vehicle from the inside if it has been locked from the outside.

There is a risk of injury or danger to life if persons remain in the vehicle for extended periods and are exposed to extreme temperatures as a result. Do not lock the vehicle from the outside when there is someone inside it.

⚠ NOTE

The door lock is fixed to the door. The door handle can be moved. Pulling the door handle when the integrated key is inserted can damage the paint or the integrated key. There is a risk of material damage. Pull out the integrated key before pulling on the outer door handle.

Removing

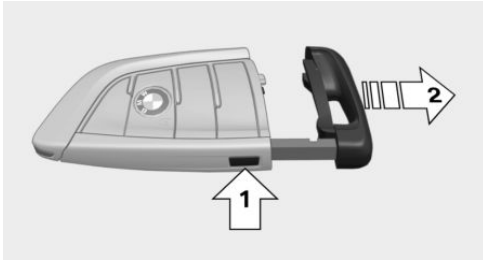

Press the button, arrow 1, and pull out the integrated key, arrow 2.

Unlocking/locking using the door lock

1. Remove cover on the door lock.

To do so, push the integrated key from underneath into the opening as far as it will go and remove the cover.

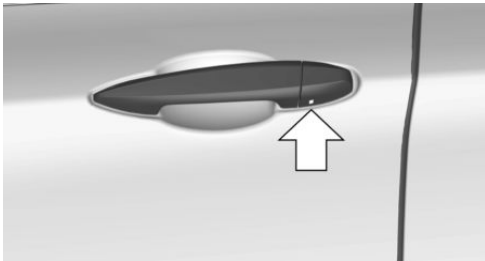

2. Unlock or lock the door lock with the integrated key.

The other doors must be unlocked or locked from the inside.

Alarm system

The alarm system is not switched on if the vehicle is locked with the integrated key.

The alarm system is triggered when the door is opened after being unlocked via the door lock.

Central locking buttons

General

In the event of an accident of sufficient severity, the vehicle is automatically unlocked. The hazard warning lights and interior lights illuminate.

Overview



Central locking buttons.

Locking

 Press the button with the front doors closed.

The fuel tank filler flap remains unlocked.

Locking does not activate the vehicle's anti-theft protection system.

Unlocking

 Press the button.

Opening

- ▶  Press the button to unlock the doors together and then pull the door handle above the armrest.
- ▶ Pull the door handle on the door to be opened. The other doors remain locked.

Comfort Access

Principle

This feature allows you to access the vehicle without having to operate the vehicle key.

Simply having the vehicle key with you, for example in your trouser pocket, is sufficient.

The vehicle automatically recognises the vehicle key when it is in the immediate vicinity or inside the vehicle.

General

Comfort Access supports the following functions:

- ▷ Unlocking and locking of the vehicle.
- ▷ Comfort closing.
- ▷ Opening of the tailgate.
- ▷ Open/close tailgate with a contactless method.

Operating requirements

- ▷ To lock the vehicle, the vehicle key must be located outside the vehicle in the vicinity of the doors.
- ▷ The vehicle can only be unlocked and locked again after approximately 2 seconds.

Unlocking



Completely grip handle of the driver's or front passenger door.

This corresponds to pressing the  button on the vehicle key.

Locking



With your finger, touch the area on the door handle of the driver's or front passenger door for approximately 1 second, without gripping the door handle.

This corresponds to pressing the  button on the vehicle key.

Comfort closing

Safety note

WARNING

Parts of the body can become trapped when the comfort closing feature is operated. There is a danger of injury. When the comfort closing feature is operating, make sure that the area of movement is kept clear.

Closing



With your finger, touch area on door handle of the driver's or front passenger door and keep your finger there without gripping door handle.

Corresponds to pressing and holding the  button on the vehicle key.

In addition to locking, the windows and the glass sunroof are closed and the exterior mirrors are folded in.

Opening the tailgate

General

To prevent the vehicle key from being locked in, do not place it in the luggage compartment.

If the tailgate is opened using Comfort Access, locked doors are not unlocked.

Safety notes

WARNING

Parts of the body can become trapped when the tailgate is operated. There is a danger of injury. When opening and closing, make sure that the area of movement of the tailgate is kept clear.

WARNING

The tailgate swings outwards when opened. There is a risk of injury or material damage. When opening and closing, make sure that the area of movement of the tailgate is kept clear.

NOTE

Pointed or angular objects can strike the windows and the heating conductors during the journey. There is a risk of material damage. Cover edges and make sure that pointed objects cannot strike the windows.

Opening

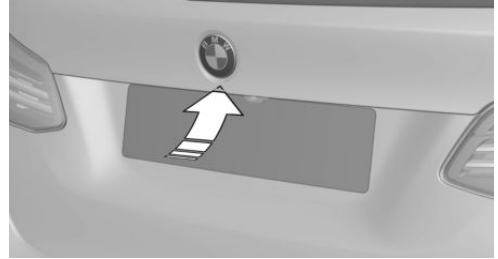

Press the button on the tailgate.

This corresponds to pressing the  button on the vehicle key.

Without automatic tailgate operation:

The tailgate is unlocked and can be opened upwards.

With automatic tailgate operation:

The tailgate is opened automatically.

With automatic operation of the tailgate: opening and closing the tailgate contactlessly

Principle

The tailgate can be opened and closed contactlessly, provided you are carrying the vehicle key with you. Two sensors detect a forward movement of the foot in the central rear area and the tailgate is opened or closed.

General

To prevent the vehicle key from being locked in, do not place it in the luggage compartment.

If the vehicle key is within the sensor range, the tailgate can be accidentally opened or closed by an unintentional or presumed foot movement.

The sensor range extends to approximately 1.50 m, 5 ft behind the rear area.

Locked doors are not unlocked when the tailgate is opened contactlessly.

Contactless opening and closing of the tailgate must be activated in the settings.

Safety notes

⚠ WARNING

When opening/closing contactlessly, there is a risk of touching vehicle parts, for example the hot exhaust system. There is a danger of injury. Make sure you are standing securely as you move your foot, and do not touch the vehicle.

⚠ WARNING

Parts of the body can become trapped when the tailgate is operated. There is a danger of injury. When opening and closing, make sure that the area of movement of the tailgate is kept clear.

⚠ WARNING

The tailgate swings outwards when opened. There is a risk of injury or material damage. When opening and closing, make sure that the area of movement of the tailgate is kept clear.

Settings

1. "My Vehicle"
2. "Vehicle settings"
3. "Doors/Key"
4. "Tailgate"
5. Select the desired setting:
 - ▶ "Open by foot movement"

Contactless opening of the tailgate is switched on or off.
 - ▶ "Close by foot movement"

Contactless closing of the tailgate is switched on or off.

Correct foot movement

1. Stand in the centre behind the vehicle, approximately an arm's length away from the rear of the vehicle.
2. Kick your foot as far as possible underneath the vehicle and immediately pull it back. Your leg must move through the ranges of both sensors.

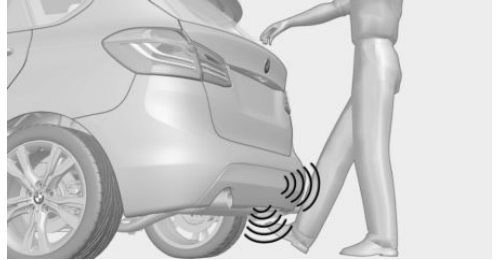

Opening

Perform the foot movement described previously.

The hazard warning lights flash before opening.

If contactless closing is switched on:

Moving the foot again will stop the opening procedure

Moving it one more time after that will close the tailgate again.

Closing

Perform the foot movement described previously.

The hazard warning lights flash and an acoustic signal sounds prior to closing.

Moving the foot again will stop the closing operation.

Moving it one more time after that will open the tailgate again.

System limits

Detection of foot movement may be restricted by the following external circumstances:

- ▶ Ice, snow or slush at the rear of the vehicle.

- ▶ Dirt or road salt at the rear of the vehicle.

Movement in the vicinity of the sensors may cause the luggage compartment to open or close unintentionally, for example if water flows underneath the vehicle during cleaning or in heavy rain. To prevent the luggage compartment from opening or closing unintentionally, make sure that the vehicle key is far enough away from the rear of the vehicle.

Malfuction

It may be difficult for the vehicle to detect the vehicle key in some conditions, including the following:

- ▶ The battery of the vehicle key is discharged. Changing the battery, see page 65.
- ▶ Disruption of the radio link by transmission masts or other equipment transmitting powerful signals.
- ▶ Shielding of the vehicle key by metallic objects.
Do not transport the vehicle key together with metallic objects.
- ▶ Disruption of the radio link by mobile telephones or other electronic devices in the immediate vicinity of the vehicle key.
Do not transport the vehicle key together with electronic devices.

Wet or snowy conditions may affect the ability of the door handles to detect a lock request.

If a fault occurs, unlock and lock the vehicle with the buttons on the vehicle key or with the integrated key, see page 66.

Tailgate

General

To prevent the vehicle key from being locked in, do not place it in the luggage compartment.

Depending on the equipment and the national-market version, it is possible to select whether the tailgate can be unlocked with the vehicle key

and how the vehicle doors respond. To adjust the settings, see page 76.

On some equipment versions, the doors are also unlocked each time.

Safety notes

WARNING

Parts of the body can become trapped when the tailgate is operated. There is a danger of injury. When opening and closing, make sure that the area of movement of the tailgate is kept clear.

WARNING

The tailgate swings outwards when opened. There is a risk of injury or material damage. When opening and closing, make sure that the area of movement of the tailgate is kept clear.

NOTE

Pointed or angular objects can strike the windows and the heating conductors during the journey. There is a risk of material damage. Cover edges and make sure that pointed objects cannot strike the windows.

Without automatic tailgate operation

Opening from outside

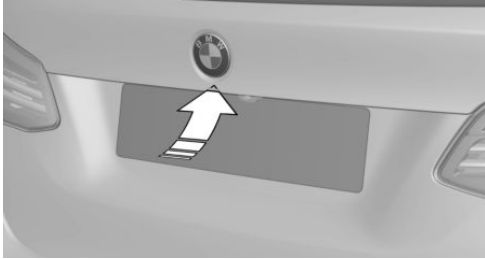

- ▷ Without Comfort Access: unlock the vehicle.
With Comfort Access: unlock the vehicle or have the vehicle key about your person.
Press the button on the tailgate.

- ▷  Press the button on the vehicle key for approximately 1 second.
If applicable, the doors are also unlocked. To unlock with the vehicle key, see page 64.

The tailgate is opened slightly and can be swung upwards.

Closing



Pull the tailgate down using the handle recess.

With automatic tailgate operation

Opening

General

When the trailer socket is in use, the tailgate cannot be opened with the vehicle key or with the button in the interior.

Adjusting the opening height

The extent to which the tailgate opens can be set.

When setting the opening height, make sure that there is a space of at least 10 cm, 4 in, above the tailgate.

1. "My Vehicle"
2. "Vehicle settings"
3. "Doors/Key"
4. "Tailgate"
5. Watch the tailgate and set the desired opening height.

From outside

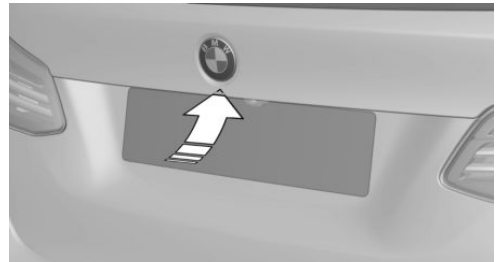

- ▷ Without Comfort Access: unlock the vehicle.
With Comfort Access: unlock the vehicle or have the vehicle key about your person.
Press the button on the outside of the tailgate.
- ▷  Press the button on the vehicle key for approximately 1 second.

If applicable, the doors are also unlocked. To open with the vehicle key, see page 64.

When the vehicle is stationary, the tailgate opens automatically up to the set opening height.

From inside



Pull up the button in the driver's door storage compartment.

When the vehicle is stationary, the tailgate opens automatically up to the set opening height.

Cancelling the opening operation

The opening procedure is interrupted in the following situations:

- ▶ If the vehicle begins to move.
- ▶ By pressing the button on the outside of the tailgate. Pressing again closes the tailgate.
- ▶ By pressing the button on the inside of the tailgate. Pressing again closes the tailgate.
- ▶ By pressing the button on the vehicle key. Pressing again resumes the opening operation.

Pressing and holding the button closes the tailgate again.

- ▶ By pressing or pulling the button in the storage compartment. Pulling again resumes the opening operation.

Closing

From outside

- ▶ Press the button on the outside of the tailgate.
- ▶  Press and hold the button on the vehicle key until the tailgate has closed.

From inside



Press and hold button in driver's door storage compartment.

For this function, the vehicle key must be inside the vehicle.

From inside of the tailgate

Without Comfort Access:

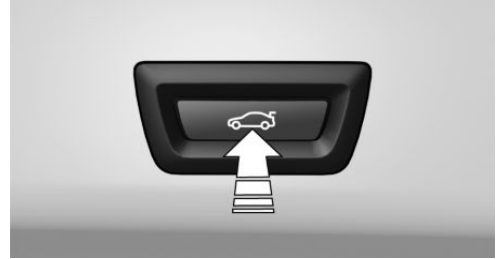

Press the button on the inside of the tailgate.

With Comfort Access:



- ▶ Press the button on the inside of the tailgate, arrow 1.
- ▶ Press the button, arrow 2.

The vehicle is locked after the tailgate has been closed. For this to happen, the driver's door must be closed and the vehicle key must be outside the vehicle in the vicinity of the tailgate.

Cancelling the closing operation

The closing procedure is interrupted in the following situations:

- ▶ When driving off suddenly.
- ▶ By pressing the button on the outside of the tailgate. Pressing again re-opens the tailgate.

- ▷ By pressing the button on the inside of the tailgate. Pressing again re-opens the tailgate.
- ▷ By releasing the button in the driver's door storage compartment. Pulling and holding the button again resumes the closing operation.
- ▷ By releasing the button on the vehicle key. Pressing and holding it again resumes the closing operation.

Malfunction

Safety note

WARNING

A jammed tailgate may move unexpectedly when being operated manually to release it. There is a risk of injury or material damage. Do not operate the tailgate manually if it is jammed. Have checks performed by a Service Partner of the manufacturer or another qualified Service Partner or a specialist workshop.

Manual operation

When operating the unlocked tailgate manually, do so slowly and without a sudden movement.

Only apply light pressure to the tailgate to fully close it. The closing operation is then performed automatically.

Driver profiles

Principle

Individual settings for several drivers can be saved in the driver profiles and retrieved as required.

General

Three profiles are provided, in which personal vehicle settings can be saved. Each vehicle key is assigned one of these driver profiles.

When the vehicle is unlocked with a vehicle key, the assigned driver profile is activated. All the settings saved in the driver profile are applied automatically.

If several drivers each use their own vehicle key, the vehicle will adjust to their personal settings when it is unlocked. These settings are also restored if the vehicle has been used in the meantime by someone with a different vehicle key.

Any changes made to settings are automatically saved to the current driver profile.

If a different driver profile is selected via iDrive, the settings saved there are automatically applied. The new driver profile is assigned to the vehicle key currently in use.

A guest profile is also available which is not assigned to any vehicle key. It can be used to perform settings on the vehicle without changing the personal driver profiles.

Operating requirements

To ensure that the correct driver profile is applied, the system needs to be able to match the detected vehicle key unambiguously with the driver.

This is ensured if the following conditions are met:

- ▷ The driver is only carrying their own vehicle key.
- ▷ The driver unlocks the vehicle.
- ▷ The driver enters the vehicle through the driver's door.

Settings

Settings for the following systems and functions, for example, are saved in the active profile. Which settings can be saved depends on the country and equipment.

- ▷ Unlocking and locking.
- ▷ Lights.
- ▷ Air conditioning.
- ▷ Radio.

- ▶ Instrument cluster.
- ▶ Functional bookmarks.
- ▶ Volumes, sound.
- ▶ Control display.
- ▶ Navigation.
- ▶ Park Distance Control PDC.
- ▶ Reversing Assist camera.
- ▶ Head-Up Display.
- ▶ Driving Experience Control.
- ▶ Seat position, exterior mirror position, steering wheel position if applicable.

The positions set via the seat memory and the last position set are saved.
- ▶ Intelligent Safety.

Profile management

Selecting a driver profile

Irrespective of which vehicle key is currently being used, it is possible to retrieve a different driver profile. This enables personal vehicle settings to be retrieved, even if the vehicle was not unlocked with the driver's own vehicle key.

Via iDrive:

1. "My Vehicle"
 2. "Driver profiles"
 3. Select a driver profile.
 4. "OK"
- ▶ The settings saved in the selected driver profile are applied automatically.
 - ▶ The selected driver profile is assigned to the currently used vehicle key.
 - ▶ If the driver profile has already been assigned to another vehicle key, this driver profile then applies to both vehicle keys.

Using a guest profile

The guest profile allows individual settings to be performed without saving them to any of the three driver profiles.

Via iDrive:

1. "My Vehicle"
2. "Driver profiles"
3. "Drive off (guest)"
4. "OK"

The guest profile cannot be renamed. It is not assigned to the currently used vehicle key.

Renaming the driver profile

To avoid mixing up driver profiles, it is possible to assign a personal name to the current driver profile.

Via iDrive:

1. "My Vehicle"
2. "Driver profiles"
3. Select a driver profile.
 -  The driver profile marked with this symbol can be renamed.
4. "Change driver profile name"
5. Enter a profile name.
6. **OK** Select the symbol.

Resetting the driver profile

The settings of the driver profile currently in use are reset to factory settings.

Via iDrive:

1. "My Vehicle"
2. "Driver profiles"
3. Select a driver profile.
 -  The driver profile marked with this symbol can be reset.
4. "Reset driver profile"
5. "OK"

Exporting a driver profile

Most of the settings of the current driver profile can be exported.

Exporting can be useful for backing up and calling up personal settings, for example before tak-

ing the vehicle into a workshop. Once backed up, the driver profiles can be taken into a different vehicle.

Via iDrive:

1. "My Vehicle"
2. "Driver profiles"
3. Select a driver profile.
 -  The driver profile marked with this symbol can be exported.
4. "Export driver profile (USB)"
 - If necessary, select the USB storage medium, see page 55.

Importing a driver profile

The existing settings of the current driver profile are overwritten with the settings of the imported driver profile.

Via iDrive:

1. "My Vehicle"
2. "Driver profiles"
3. Select the driver profile to be overwritten.
 -  The driver profile marked with this symbol can be overwritten.
4. "Import driver profile (USB)"
 - If necessary, select the USB storage medium.
5. Select the driver profile to be imported.

Displaying the driver profiles when starting

The driver profiles can be shown every time the vehicle is started so that the desired profile can be selected.

Via iDrive:

1. "My Vehicle"
2. "Driver profiles"
3. "Show driver profiles at start"

System limits

It is not always possible to match a vehicle key unambiguously to a driver. This may be the case in the following scenarios:

- ▶ The front passenger unlocks the vehicle with their vehicle key, but another person is driving.
- ▶ The driver unlocks the vehicle using Comfort Access and is carrying a number of vehicle keys.
- ▶ If there is a change of driver without the vehicle being locked and unlocked.
- ▶ If a number of vehicle keys are located in the area outside of the vehicle.

Settings

General



Various settings are possible for the vehicle key functions depending on the equipment and the national-market version.

These settings are saved for the current driver profile, see page 74.

Unlocking

Doors

Via iDrive:

1. "My Vehicle"
2. "Vehicle settings"
3. "Doors/Key"
4.  "Driver's door" or  "All doors"
5. Select the desired setting:
 - ▶ "Driver's door only"
 - Only the driver's door and fuel tank filler flap are unlocked. Pressing again unlocks the entire vehicle.
 - ▶ "All doors"
 - The entire vehicle is unlocked.

Tailgate

Depending on the equipment and national-market version, these settings may not be available.

Via iDrive:

1. "My Vehicle"
2. "Vehicle settings"
3. "Doors/Key"
4. 

The text next to the symbol indicates the current setting.

5. Select the desired setting:

- ▷ "Tailgate"

Depending on equipment, the tailgate is unlocked or opened.

- ▷ "Tailgate and door(s)"

Depending on equipment, the tailgate is unlocked or opened and the doors are unlocked.

- ▷ "Tailgate opens after unlocking"

The vehicle must be unlocked before the tailgate can be operated with the vehicle key.

- ▷ "Lock button"

It is not possible to operate the tailgate with the vehicle key.

Setting the last seat and mirror position

Via iDrive:

1. "My Vehicle"
2. "Driver profiles"
3. Select a driver profile.

 The setting can be made for the driver profile marked with this symbol.

4. "Last seat position automatic"

When the vehicle is unlocked, the driver's seat and exterior mirrors are adjusted to their last set positions.

The last position setting is independent of settings saved via the seat memory.

Vehicle acknowledgement signals

Via iDrive:

1. "My Vehicle"
2. "Vehicle settings"
3. "Doors/Key"
4. "Flash for lock/unlock"

Unlocking is acknowledged by two flashes, locking by one flash.

Automatic locking

Via iDrive:

1. "My Vehicle"
2. "Vehicle settings"
3. "Doors/Key"
4. Select the desired setting:

- ▷ "Relock automatically"

The vehicle is automatically locked again after a short while if no doors are opened after unlocking.

- ▷ "Lock after pulling away"

On driving off, the vehicle is locked automatically.

Automatic unlocking

Via iDrive:

1. "My Vehicle"
2. "Vehicle settings"
3. "Doors/Key"
4. "Unlock at end of journey"

After the engine is switched off by pressing the Start/Stop button, the locked vehicle is unlocked automatically.

Alarm system

General

The alarm system responds to the following changes in a locked vehicle:

- ▷ Unauthorised opening of a door, the bonnet or the tailgate.
- ▷ Movement inside the vehicle.
- ▷ A change in vehicle inclination, for instance if an attempt is made to jack it up and steal the wheels or to raise it prior to towing away.
- ▷ An interruption in the power supply from the battery.
- ▷ Improper use of the socket for on-board diagnosis.
- ▷ Locking of the vehicle while a device is connected to the socket for on-board diagnosis OBD. For socket for on-board diagnosis OBD, see page 288.

The alarm system indicates these changes visually and audibly:

- ▷ Audible alarm:
Depending on local regulations, the acoustic alarm may be suppressed.
- ▷ Visual alarm:
By flashing of the hazard warning lights and, if applicable, the headlights.

To safeguard operation of the alarm system, do not modify the system.

Switching on/off

The alarm system is switched off or on as soon as the vehicle is unlocked or locked with the vehicle key or using Comfort Access.

Opening the doors when the alarm system is switched on

The alarm is triggered when a door is opened if it has been unlocked via the door lock using the integrated key.

To stop the alarm, see page 79.

Opening the tailgate with the alarm system switched on

The tailgate can be opened even with the alarm system switched on.

When re-closed, the tailgate is locked and monitored again provided that the doors are locked. The hazard warning lights flash once.

Indicator lamp on the interior mirror

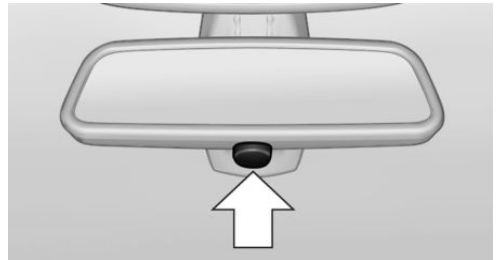

- ▷ Indicator lamp flashes every 2 seconds:
The alarm system is switched on.
- ▷ Indicator lamp flashes for approximately 10 seconds then switches to flashing every 2 seconds:
The interior movement detector and tilt alarm sensor are not active because the doors, bonnet or tailgate are not closed correctly. Correctly closed access points are secured.
Once the remaining open access points have been closed, the interior movement detector and tilt alarm sensor are switched on.
- ▷ The indicator lamp extinguishes after the vehicle has been unlocked:
This means that the vehicle is not being tampered with.
- ▷ The indicator lamp flashes after unlocking until the ignition is switched on, but for no longer than approximately 5 minutes:
The alarm has been triggered.

Tilt alarm sensor

The vehicle's angle of inclination is monitored.

The alarm system responds, for example when there is an attempt to steal a wheel or tow the vehicle away.

Interior movement detector

To ensure perfect functioning, the windows and glass sunroof must be closed.

Avoiding false warnings

General

The tilt alarm sensor and the interior movement detector may trigger an alarm without any unauthorised activity taking place.

Situations where false warnings may occur:

- ▷ In washing bays or car washes.
- ▷ In two-level garages.
- ▷ When transporting the vehicle via motorail, car ferry or trailer.
- ▷ When there are pets in the vehicle.
- ▷ When the vehicle is locked after starting to refuel.

The tilt alarm sensor and interior movement detector can be switched off for such situations.

Switching off the tilt alarm sensor and interior movement detector



Within 10 seconds of locking the vehicle, press the button on the vehicle key.

The indicator lamp illuminates for approximately 2 seconds and then flashes again.

The tilt alarm sensor and the interior movement detector are switched off until the next time the vehicle is locked.

Stopping the alarm

- ▷ Unlock the vehicle with the vehicle key.

- ▷ Unlock the vehicle with the integrated key and switch on the ignition using the emergency detection of the vehicle key, see page 65.
- ▷ With Comfort Access:
 - Fully grip the handle of the driver's or front passenger door while carrying the vehicle key.

Power window switches

General

In an accident of appropriate severity, the windows are automatically closed until just a small gap remains.

In the radio-ready state, the windows can still be operated for an extended period of time. After the radio-ready state has been switched off, the windows can still be operated for approx. one minute.

Safety note

WARNING

Parts of the body can become trapped when the windows are operated. There is a risk of injury or material damage. When opening and closing, make sure that the area of movement of the windows is kept clear.

Overview





Power window switches



Safety switch

Opening

- ▶  Push the switch as far as the resistance point.

The window opens for as long as the switch is held.

- ▶  Push the switch past the resistance point.

The window is opened automatically. Pressing the switch again stops the movement.

For comfort opening with the vehicle key, see page 63.

Closing

- ▶  Pull the switch as far as the resistance point.

The window closes for as long as the switch is held.

- ▶  Pull the switch past the resistance point.

The window closes automatically if the door is closed. Pulling the switch again stops the movement.

For comfort closing with the vehicle key, see page 64.

To close using Comfort Access, see page 68.

Anti-trap mechanism

Principle

The anti-trap mechanism prevents objects or parts of the body from becoming trapped between the door frame and window while a window is being closed.

General

If resistance or a blockage is detected while a window is being closed, the closing operation is interrupted.



Safety note

WARNING

Accessories on the windows, for example aerials, can impair the anti-trap mechanism. There is a danger of injury. Do not attach any accessories within the area of movement of the windows.

Closing with no anti-trap mechanism

If an external hazard or ice prevents you from closing the windows normally, proceed as follows:

1.  Pull the switch past the resistance point and hold it in this position.
The window is closed but with limited anti-trap mechanism. If the closing force exceeds a certain level, the closing operation is interrupted.
2.  Pull the switch past the resistance point again within approximately 4 seconds and hold it in this position.

The window is closed with no anti-trap mechanism.

Safety switch

General

The safety switch can be used to prevent children from opening and closing the rear windows with the switches in the rear, for example.

In the event of an accident of sufficient severity, the safety function is automatically switched off.

Switching on/off



Press the button.

The LED is illuminated when the safety function is switched on.

Panoramic glass sunroof

General

In the event of an accident of sufficient severity, the glass sunroof is automatically unlocked.

Safety note

WARNING

Parts of the body may become trapped when the glass sunroof is operated. There is a danger of injury. When opening and closing, make sure that the area of movement of the glass sunroof is kept clear.

Overview



Raising glass sunroof and closing raised glass sunroof



Push the switch briefly up.

- ▶ The closed glass sunroof is raised and the sun guard opens slightly.
- ▶ The opened glass sunroof closes to the raised position.

The sun guard does not move.

- ▶ The raised glass sunroof is closed.

Opening/closing the glass sunroof and sun guard separately

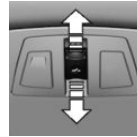

- ▶ Slide the switch backwards as far as the resistance point and hold.

The sun guard continues to open for as long as the switch is pressed. If the sun guard is already fully open, the glass sunroof is opened.

- ▶ Slide the switch forwards as far as the resistance point and hold.

The glass sunroof closes for as long as the switch is held. If the glass sunroof is already closed or is in the raised position, the sun guard is closed.

- ▶ Slide the switch backwards beyond the resistance point.

The sun guard is opened automatically. If the sun guard is already fully open, the glass sunroof is opened automatically.

Pressing the switch again stops the movement.

- ▶ Slide the switch forwards beyond the resistance point.

The glass sunroof is closed automatically. If the glass sunroof is already closed or is in the raised position, the sun guard is closed automatically.

Pressing the switch again stops the movement.

Opening/closing the glass sunroof and sun guard together

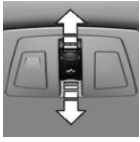

- ▶ Press the switch back beyond the resistance point twice in quick succession.

The glass sunroof and the sun guard open together.

Pressing the switch again stops the movement.

- ▶ Press the switch forwards beyond the resistance point twice in quick succession.
The glass sunroof and the sun guard close together.
Pressing the switch again stops the movement.

For comfort opening with the vehicle key, see page 63.

For comfort closing with the vehicle key, see page 64.

To close using Comfort Access, see page 68.

Comfort position

In some models, the wind noises in the car's interior are lowest when the glass sunroof is not fully open. In these models, the automatic function initially only opens the glass sunroof as far as this comfort position.

Pressing the switch again opens the glass sunroof fully.

After switching off the ignition

The glass sunroof can still be opened or closed for approximately 1 minute after the ignition has been switched off.

Anti-trap mechanism

General

If resistance or a blockage is detected while the glass sunroof is being closed, the closing operation is interrupted once the roof reaches the half-

open position or it is stopped when closing from the raised position.

The glass sunroof is opened slightly.

Closing with no anti-trap mechanism from an open position

In the event of danger from outside, proceed as follows:

1. Slide the switch forwards beyond the resistance point and hold it in this position.

The glass sunroof is closed with limited anti-trap mechanism. If the closing force exceeds a certain level, the closing operation is interrupted.

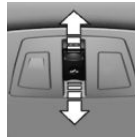

2. Press the switch forwards once again beyond the resistance point and hold until the glass sunroof closes with no anti-trap mechanism. Ensure that the closing area is clear.

Closing with no anti-trap mechanism from a raised position

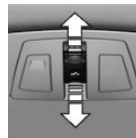

In the event of danger from outside, slide the switch forwards beyond the resistance point and hold it there.

The glass sunroof is closed with no anti-trap mechanism.

Initialising after a power failure

General

If a power failure occurs while the glass sunroof is opening or closing, it may only have limited functionality afterwards.

The system can be initialised if the following conditions are met.

- ▶ The vehicle is parked on level ground.

- ▶ The vehicle does not move until initialisation is complete.
- ▶ The engine is running.
- ▶ The outside temperature is above 5 °C/41 °F.

During initialisation, the glass sunroof closes with no anti-trap mechanism.

Ensure that the closing area is clear.

Initialising the system

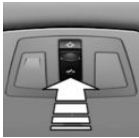

Press the switch up and hold until initialisation is complete.

Initialisation begins within 15 seconds.

- ▶ If the glass sunroof is closed, it opens, then closes again.
- ▶ If the glass sunroof is open, it first closes, then opens and closes again.

Initialisation is complete once the glass sunroof and sun guard have opened then closed again.

Seats, mirrors and steering wheel

Vehicle equipment

This chapter describes all standard, country-specific and optional equipment available for the model series. It may therefore describe equipment and functions which are not installed in your vehicle, for example on account of the optional equipment selected or the national-market version. This also applies to safety-relevant functions and systems. Please comply with the relevant laws and regulations when using the corresponding functions and systems.

Safe seating position

A seating position that suitably meets the needs of the occupants is essential for relaxed driving with minimum fatigue.

In an accident, the correct seating position plays an important role. For safe driving, additionally note the following chapters:

- ▷ Seats, see page 84.
- ▷ Seat belts, see page 88.
- ▷ Head restraints, see page 91.
- ▷ Airbags, see page 152.

Front seats

Safety notes

⚠ WARNING

Adjusting the seat during a journey could cause the seat to move unexpectedly. You could lose control of the vehicle. There is a risk of accident. Only adjust the seat on the driver's side when at a standstill.

⚠ WARNING

If the backrest is angled too far back, the protective function of the seat belt will no longer be guaranteed. There is a risk of sliding under the seat belt in the event of an accident. There is a risk of injury or even death. Adjust the seat before starting the journey. Adjust the backrest to the most upright position possible, and do not change it during the journey.

⚠ WARNING

There is a risk of entrapment when the seats are moved. There is a risk of injury or material damage. Before making any adjustment, make sure that the area of movement of the seat is clear.

Manually adjustable seats

Overview

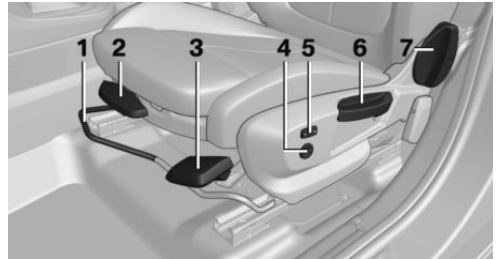

- 1 Longitudinal direction
- 2 High support
- 3 Seat angle
- 4 Lumbar support
- 5 Backrest width
- 6 Height
- 7 Backrest angle

Longitudinal direction

WARNING

If the seat is not locked, it could move unexpectedly during a journey. You could lose control of the vehicle. There is a risk of accident. After making an adjustment, move the seat forwards or backwards slightly to ensure that it is properly engaged.

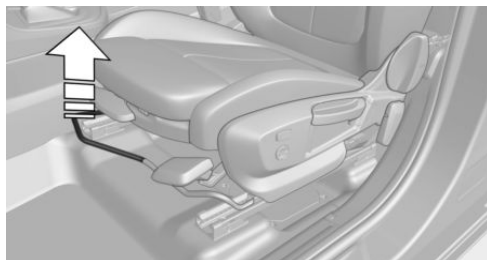

Pull the lever and slide the seat in the desired direction.

Height

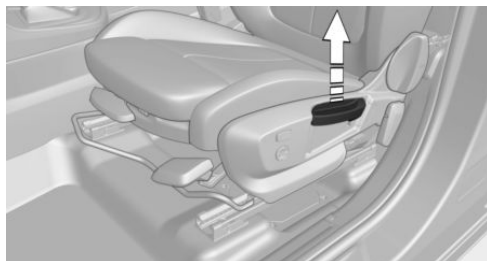

Pull the lever up or press the lever down as often as needed until the desired height is reached.

Backrest angle

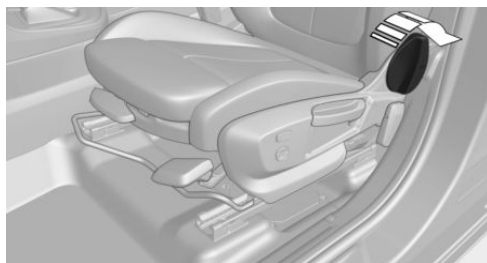

Push the lever and add or remove pressure on the backrest as required.

Seat angle

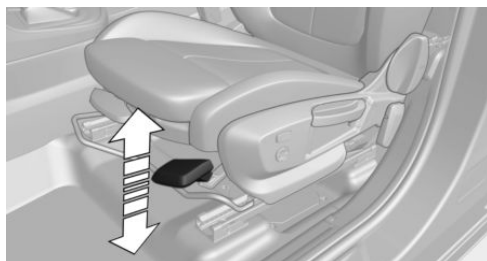

Pull the lever up or press the lever down repeatedly until the desired seat angle is reached.

Electrically adjustable seats

General

The driver's seat setting is saved for the current profile. When the vehicle is unlocked with the vehicle key, this setting is retrieved automatically provided that the function, see page 77, has been activated.

The current seat position can be saved using the memory function, see page 93.

Overview

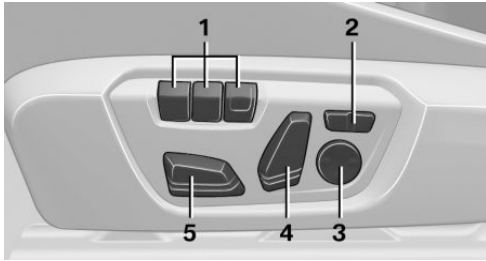

- 1 Memory function
- 2 Backrest width
- 3 Lumbar support
- 4 Backrest angle
- 5 Forward/back, height, seat angle

Seat angle

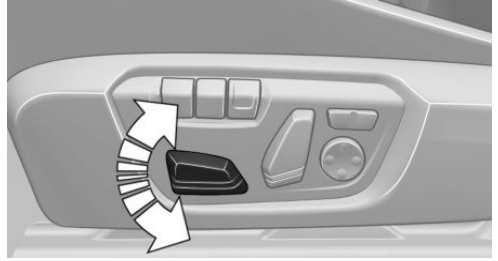

Tilt the switch up or down.

Backrest angle

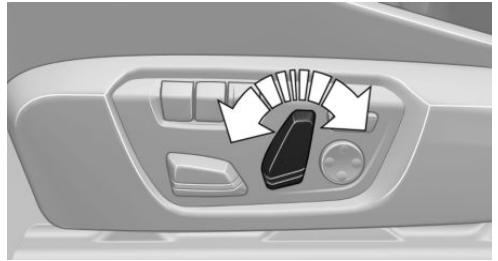

Tilt the switch forwards or backwards.

Longitudinal direction

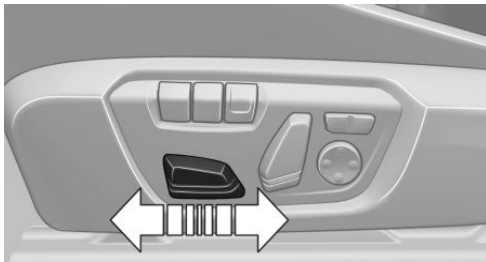

Press the switch forwards or backwards.

Thigh support

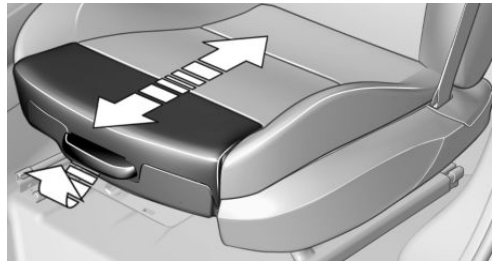

Pull the lever on the front of the seat and adjust the thigh support.

Height

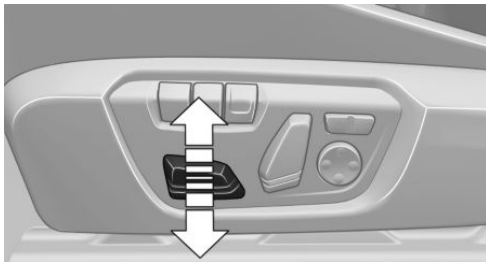

Press the switch up or down.

Lumbar support

The curvature of the backrest can be changed to provide support for the lumbar region, or lordosis. The upper edge of the pelvis and the spinal

column are supported to encourage an upright posture.



- ▶ Press the button at the front/rear:
The curvature is increased/decreased.
- ▶ Press the button at the top/bottom:
The curvature is shifted upwards/downwards.

Backrest width

Principle

To adjust the backrest width can improve lateral support when taking corners.

General

To change the width of the backrest, the side cushions of the backrest can be adjusted.

Adjusting



- ▶ Press the button forward: backrest width is reduced.
- ▶ Press the button back: backrest width is increased.

Seat heating, front

Overview



Seat heating

Switching on



Press the button once for each temperature level.

The highest setting is selected if the three LEDs are illuminated.

If you stop the vehicle temporarily and then resume your journey within approximately 15 minutes, the seat heating is automatically re-activated at the last setting.

If ECO PRO is activated, see page 246, the heating power is reduced.

Switching off



Press and hold the button until the LEDs are extinguished.

Rear seats

Two rows of seats

Safety notes

WARNING

There is a risk of entrapment when folding down the centre armrest in rear. There is a danger of injury. When folding down, make sure that the area of movement of the centre armrest is kept clear.

WARNING

The rear seat backrests may move unexpectedly during a journey if they are unintentionally released via the loops. There is a danger of injury. Use the loops solely for releasing the rear seat backrests. Do not attach objects to the loops.

Longitudinal direction

General

The rear seat is split 60–40. The left-hand seat is connected to the middle part.

Adjusting

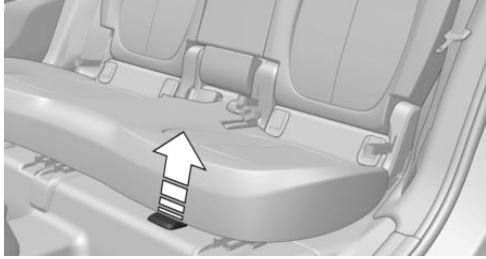

Pull the lever and slide the seat in the desired direction.

After releasing the lever, move the seat forwards or backwards slightly to ensure that it is properly engaged.

Backrest angle

1. Pull the loop to unlock the rear seat backrest.

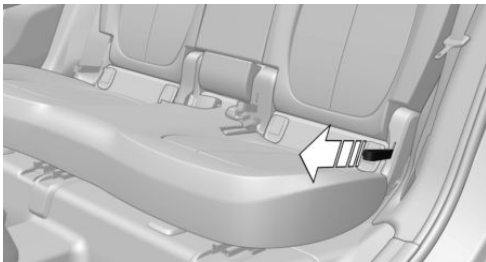

2. Add or remove pressure on the backrest as required.

After making an adjustment, move the backrest forwards or backwards slightly to ensure that it is properly engaged.

Seat belts

General

For the safety of the vehicle occupants, the vehicle is equipped with five seat belts. However, they can only provide protective effect when worn correctly.

Before every journey, make sure that all occupants have fastened their seat belts. The airbags supplement the seat belts as an additional safety device and are not a substitute for the seat belts.

All belt fastening points are designed to achieve the best possible protective effect of the seat belts with proper use of the seat belts and correct seat setting. Follow notes on sitting safely, see page 84.

The two outer seat belt buckles on the rear seat are intended for those sitting on the left and right.

The inner seat belt buckles of the rear seat are intended for the person sitting in the middle.

Safety notes

WARNING

If a seat belt is used by more than one person at the same time, the protective function of the seat belt is no longer guaranteed. There is a risk of injury or even death. Only one person should use each seat belt at any one time. Do not allow infants and children to travel on the lap of another occupant. Instead, secure the infant or child in a child restraint system intended for this purpose.

WARNING

The protective function of the seat belts may be limited or may even fail completely if the seat belts are worn incorrectly. If a seat belt is not worn correctly, additional injuries can be caused, for example in the event of an accident, braking or evasive action. There is a risk of in-

jury or even death. Make sure that all vehicle occupants have fastened their seat belts correctly.

WARNING

Seat belts are designed to bear upon the bony structure of the body and should be worn low across the front of the pelvis, or the pelvis, chest and shoulders, as applicable. Wearing the lap section of the belt across the abdominal area must be avoided.

Seat belts should be adjusted as firmly as possible, consistent with comfort, to provide the protection for which they have been designed. A slack seat belt will greatly reduce the protection afforded to the wearer.

Care should be taken to avoid contamination of the webbing by polishes, oils and chemicals and particularly battery acid. Cleaning may safely be carried out using a mild soap and water solution. The seat belt should be replaced if the seat belt strap becomes frayed, contaminated or damaged. Seat belts should not be worn with straps twisted. Each seat belt assembly must only be used by one occupant; it is forbidden to put a belt around a child being carried on the occupant's lap.

It is essential to replace the entire assembly after it has been worn in a severe impact even if damage to the assembly is not obvious.

WARNING

No modifications or additions should be made by the user that will either prevent the seat belt adjusting devices from operating to remove slack, or prevent the seat belt assembly from being adjusted to remove slack.

WARNING

If the rear seat backrest is not locked, the protective effect of the middle seat belt is not ensured. There is a risk of injury or even death. Lock the wider rear seat backrest when using the middle seat belt.

WARNING

The protective function of the seat belts may be limited or may even fail completely in the following situations:

- ▷ If the seat belts or belt buckles are damaged, dirty or have been modified in another way.
- ▷ If the belt tensioners or belt retractors have been modified.

Seat belts can be damaged in an accident without the damage necessarily being apparent. There is a risk of injury or even death. Do not modify seat belts, belt buckles, belt tensioners, belt retractors and belt anchor points and ensure that they are kept clean. After an accident, have the seat belts inspected at a Service Partner of the manufacturer or another qualified Service Partner or a specialist workshop.

Correct seat belt use

- ▷ Place the seat belt tightly over the pelvis and shoulder, close to the body and without twisting.
- ▷ Make sure that the seat belt is positioned low at the hips in the area of the pelvis. The seat belt must not press on the abdomen.
- ▷ The seat belt must not be allowed to rub against sharp edges, be routed over solid or breakable objects or be trapped.
- ▷ Avoid wearing bulky clothing.
- ▷ Keep the seat belt taut by occasionally pulling upwards on the upper section.

Adjustment for automatic retracting seat belts

- ▶ Draw the buckle tongue attached to the seat belt across the body and press it into the buckle catch until a 'click' is heard.
- ▶ Adjustment of the belt length is very important. To adjust the lap belt and check whether the buckle has locked correctly, pull upwards on the shoulder strap until the lap belt fits tightly.
- ▶ The length of the diagonal shoulder strap adjusts itself automatically to allow freedom of movement.
- ▶ To release the seat belt, press the button on the buckle catch unit.

Fastening the seat belt

1. When fastening the seat belt, guide it slowly over the shoulder and pelvis.
2. Insert the seat belt tongue in the belt buckle. The seat belt buckle must be heard to engage.

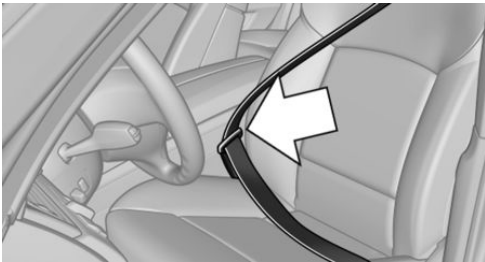

Unfastening the seat belt

1. Hold the seat belt firmly.
2. Press the red button on the belt buckle.
3. Guide the seat belt back up to the reel mechanism.

Middle seat belt in the rear

Fastening the seat belt

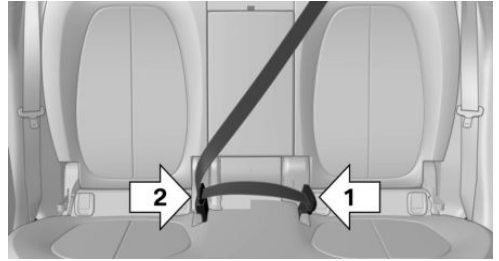

1. Pull the seat belt tongues out of the holder in the roof.
 2. Insert the lower seat belt tongue in the belt lock, arrow 1.
 3. Insert upper seat belt tongue in belt lock, arrow 2.
- Belt locks must engage audibly.

Unfastening the seat belt

1. Hold the seat belt firmly.
2. Press the red button on the belt buckle.
3. Use the seat belt tongue, arrow 1, to open the second belt buckle, arrow 2.

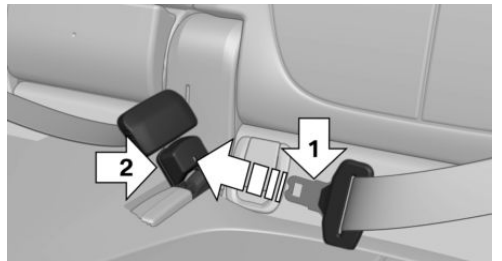

4. Guide the seat belt to the holder in headliner.

Seat belt reminder for driver and front seat passenger seat

General

The seat belt reminder is activated when the seat belt on the driver's side is not fastened.

On some national-market versions, the seat belt reminder is also active if the front passenger seat belt is not fastened and heavy objects are on the front passenger seat.

Display in the instrument cluster



A Check Control message is shown. Check whether the seat belt has been fastened correctly.

Seat belt reminder for rear seats

General

The seat belt reminder is automatically activated every time the engine starts.

The seat belt reminder will also be activated if a rear seat belt is unfastened during the journey.

Display in the instrument cluster

The indicator lamp in the instrument cluster is illuminated after the engine starts.

Symbol	Description
	Green: seat belt fastened on the corresponding rear seat.
	Red: seat belt not fastened on the corresponding rear seat.



Front head restraints

Safety notes

WARNING

If the head restraints are removed or incorrectly adjusted, they cannot provide protection as intended and head and neck injuries may result. There is a danger of injury.

- ▷ Before a journey, re-install any removed head restraints on all occupied seats.

- ▷ Adjust the head restraint so that its centre supports the back of the head at eye level where possible.
- ▷ Adjust the distance so that the head restraint is as close as possible to the back of the head. If necessary, adjust the distance by adjusting the backrest angle.

WARNING

Parts of the body can become trapped when the head restraints are moved. There is a danger of injury. When moving the head restraint, make sure that the area of movement is kept clear.

WARNING

Objects on the head restraint impair the protective function of the head restraint in the head and neck area. There is a danger of injury.

- ▷ Do not fit any covers on the seats or head restraints.
- ▷ Do not hang objects such as coat hangers directly on the head restraint.
- ▷ Only use accessories that have been classified as safe for attaching to the head restraint.
- ▷ Do not use any accessories, for example cushions, during the journey.

Adjusting the height

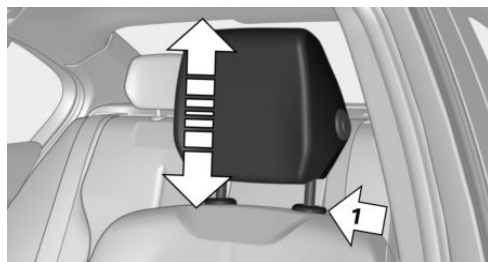

- ▷ Up: push the head restraint upwards.

- ▷ Down: press the button, arrow 1, and slide the head restraint downwards.

After adjusting the height, make sure that the head restraint engages correctly.

Removing

Only remove the head restraint if no-one is intending to sit in the seat in question.

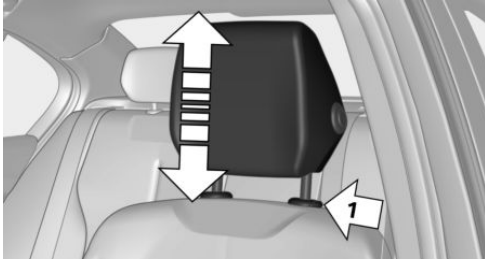

1. Push the head restraint up until resistance is felt.
2. Press the button, arrow 1, and pull the head restraint fully out.

Installing

Proceed in the reverse order to install the head restraint.

Rear head restraints

Safety notes

⚠ WARNING

If the head restraints are removed or incorrectly adjusted, they cannot provide protection as intended and head and neck injuries may result. There is a danger of injury.

- ▷ Before a journey, re-install any removed head restraints on all occupied seats.
- ▷ Adjust the head restraint so that its centre supports the back of the head at eye level where possible.

- ▷ Adjust the distance so that the head restraint is as close as possible to the back of the head. If necessary, adjust the distance by adjusting the backrest angle.

⚠ WARNING

Parts of the body can become trapped when the head restraints are moved. There is a danger of injury. When moving the head restraint, make sure that the area of movement is kept clear.

⚠ WARNING

Objects on the head restraint impair the protective function of the head restraint in the head and neck area. There is a danger of injury.

- ▷ Do not fit any covers on the seats or head restraints.
- ▷ Do not hang objects such as coat hangers directly on the head restraint.
- ▷ Only use accessories that have been classified as safe for attaching to the head restraint.
- ▷ Do not use any accessories, for example cushions, during the journey.

Height

Adjusting

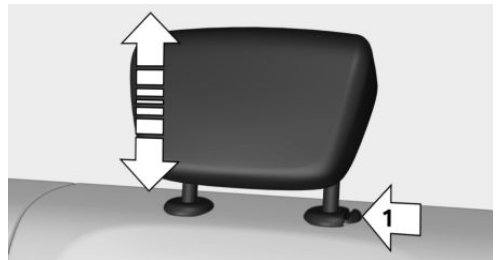

- ▷ Down: press the button, arrow 1, and slide the head restraint downwards.

- ▶ Up: push the head restraint upwards.

After adjusting the height, make sure that the head restraint engages correctly.

Removing

Only remove the head restraint if no-one is intending to sit in the seat in question.

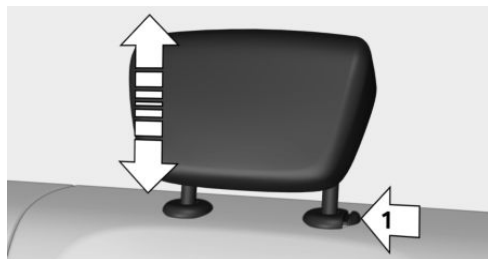

1. Push the head restraint up until resistance is felt.
2. Press the button, arrow 1, and pull the head restraint fully out.

Installing

Proceed in the reverse order to install the head restraint.

Memory function

Principle

The memory function enables the following settings to be stored and retrieved when required:

- ▶ Seat position.
- ▶ Exterior mirror position.
- ▶ Height of the Head-Up Display.

General

Two memory slots can be assigned with different settings.

Depending on the equipment, the following settings are not saved:

- ▶ Backrest width.

- ▶ Lumbar support.

Safety notes

⚠ WARNING

Using the memory function while driving may cause the seat to move unexpectedly. You could lose control of the vehicle. There is a risk of accident. Only call up the memory function when the vehicle is at standstill.

⚠ WARNING

There is a risk of entrapment when the seats are moved. There is a risk of injury or material damage. Before making any adjustment, make sure that the area of movement of the seat is clear.

Overview



Saving

1. Switch on the ignition.
2. Set the desired position.
3.  Press the button. The LED in the button is illuminated.
4. Press the desired button 1 or 2 while the LED is illuminated. The LED is extinguished.

 If the button was pressed inadvertently:
Press the button again.

The LED is extinguished.

Retrieving settings

The saved position is retrieved automatically.

Press the desired button 1 or 2.

The operation is halted when you press a seat adjustment switch or one of the memory buttons.

Adjustment of the driver's seat position is disabled a short while after driving off.

Recall disabled

Recall of the saved seat positions is disabled after a short while to protect the battery.

To reactivate recall:

- ▷ Open or close a door or the tailgate.
- ▷ Press a button on the vehicle key.
- ▷ Press the Start/Stop button.

Mirrors

Exterior mirrors

General

The mirror setting is saved for the current driver profile. When the vehicle is unlocked with the vehicle key, this setting is retrieved automatically provided that the function, see page 77, has been activated.

The current exterior mirror position can be saved with the memory function, see page 93.

Safety note

WARNING

Objects reflected in the mirror are closer than they appear. The distance from road users behind the vehicle could be incorrectly estimated, for example when changing lane. There is a risk of accident. Look over your shoulder to estimate the distance from following traffic.

Overview



- 1 To adjust
- 2 To select a mirror, automatic parking function
- 3 Folding in and out

Selecting a mirror



To switch to the other mirror:
Push the switch.

Electrical adjustment



Press the button.

The mirror moves according to the button movement.

Malfunction

In the event of an electrical fault, press the edges of the mirror glass to adjust the mirror.

Folding in and out

NOTE

Because of its width, the vehicle could sustain damage in car washes. There is a risk of material damage. Before washing, fold the mirrors in manually or with the button.



Press the button.

The mirrors can be folded in at vehicle speeds up to approx. 20 km/h, 15 mph.

Folding the mirrors in and out is useful in the following situations:

- ▷ In car washes.
- ▷ In narrow streets.

Mirrors which are folded in automatically fold out when the vehicle reaches a speed of approximately 40 km/h, 25 mph.

Automatic heating

If required, both exterior mirrors are automatically heated when the ignition is switched on.

Automatic dimming

The exterior mirror on the driver's side is dimmed automatically. Photocells in the interior mirror are used to control this function.

Automatic parking function, exterior mirror

Principle

When reverse gear is engaged, the passenger-side mirror glass is tilted downwards. When parking, for example, this gives the driver a better view of the kerb or other objects near the ground.

Activating

1.  Push the switch to the driver's mirror position.
2. Engage selector lever position R.

The automatic parking function is deactivated when the trailer socket is in use.

Deactivating

Push the switch to the passenger-side mirror position.

Interior mirror, manual dim

Turning button

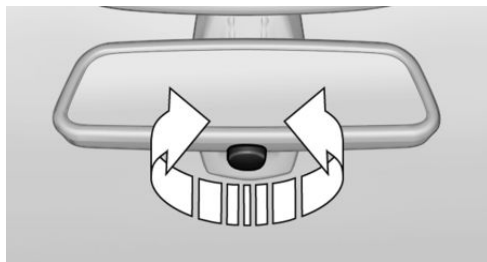

Reduce glare from the interior mirror by turning the button.

Interior mirror with automatic dimming function

Overview

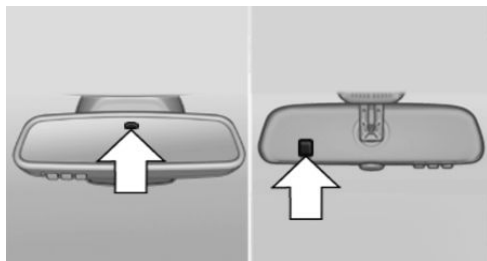

The function is controlled by photocells:

- ▷ In the mirror glass.
- ▷ On the back of the mirror.

Operating requirements

- ▷ Keep the photocells clean.
- ▷ Do not obstruct the zone between the interior mirror and the windscreen.

Steering wheel

Safety note

WARNING

Adjusting the steering wheel while driving may cause the steering wheel to move unexpectedly. You could lose control of the vehicle. There is a risk of accident. Only adjust the steering wheel when the vehicle is at a standstill.

Adjusting

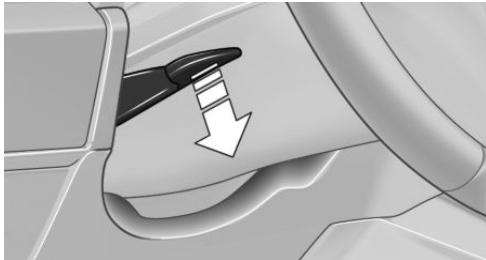

1. Switch on the ignition.
2. Fold the lever down.
3. Move the steering wheel to the preferred height and angle to suit your seating position.
4. Fold the lever back up.
5. Switch off the ignition again if necessary.

Steering wheel heating

Overview



Steering wheel heating

Switching on/off



Press the button.

- ▷ On: the LED is illuminated.
- ▷ Off: the LED is extinguished.

Electric steering wheel lock

General

Depending on the vehicle equipment, the steering wheel locks automatically when the driver's door is opened from inside.

Switch on standby state to unlock.

Safety note

WARNING

If steering wheel lock is activated, the vehicle cannot be steered. There is a risk of accident. Switch on the ignition prior to moving the vehicle.

Carrying children safely

Vehicle equipment

This chapter describes all standard, country-specific and optional equipment available for the model series. It may therefore describe equipment and functions which are not installed in your vehicle, for example on account of the optional equipment selected or the national-market version. This also applies to safety-relevant functions and systems. Please comply with the relevant laws and regulations when using the corresponding functions and systems.

Important considerations

Safety notes

WARNING

Unsupervised children or pets in the vehicle can set the vehicle in motion and endanger themselves or other road users, for example by the following actions:

- ▷ Pressing the Start/Stop button.
- ▷ Releasing the parking brake.
- ▷ Opening and closing doors or windows.
- ▷ Engaging selector lever position N.
- ▷ Operating vehicle equipment.

There is a risk of accident or injury. Do not leave children or pets unsupervised in the vehicle. When leaving the vehicle, take the vehicle key with you and lock the vehicle.

WARNING

Hot vehicles can have fatal consequences, in particular for children or pets. There is a risk of injury or even death. Do not leave anyone unsupervised in the vehicle, especially children or pets.

WARNING

Child restraint systems and their parts can get very hot when exposed to direct sunlight. Contact with hot parts can cause burns. There is a danger of injury. Do not expose the child restraint system to direct sunlight; cover the child restraint system if necessary. If necessary, allow the child restraint system to cool down before transporting a child. Do not leave children unsupervised in the vehicle.

Children on the rear seats

General

Accident research has shown that the safest place for children is on the rear seat.

Wherever possible, children younger than 12 years old or shorter than 150 cm, 5 ft should only be transported in the rear using child restraint systems appropriate for their age, weight and stature. Children aged 12 years and older must be secured with a seat belt as soon as use of a child restraint system is no longer appropriate due to their age, weight or stature.

Safety note

WARNING

Children shorter than 150 cm, 5 ft cannot wear the seat belt correctly without using additional child restraint systems. The protective function of the seat belts may be limited or may even fail completely if the seat belts are worn incorrectly. If a seat belt is not worn correctly, additional injuries can be caused, for example in the event of an accident, braking or evasive action. There is a risk of injury or even death. Children shorter than 150 cm, 5 ft must be secured in suitable child restraint systems.

Not for Australia/New Zealand: Children on the front passenger seat

General

When using a child restraint system on the front passenger seat, make sure that the front and side airbags on the passenger side are deactivated. Front passenger airbags can only be deactivated with the key switch for front passenger airbags, see page 154. If the front passenger airbags cannot be deactivated, do not carry children on the front passenger seat, even in suitable child restraint systems.

Safety notes

WARNING

Active front passenger airbags can injure a child in a child restraint system when they deploy. There is a danger of injury. Make sure that the front passenger airbags are deactivated and the PASSENGER AIRBAG OFF indicator lamp is illuminated.

Fitting child restraints

General

When selecting, installing and using child restraint systems, comply with the information provided by the manufacturer of the child restraint system.

Safety notes

WARNING

If the seat is not adjusted properly or the child seat has been installed incorrectly, the child restraint system may have limited stability or may not be stable at all. There is a risk of injury or even death. Make sure that the child restraint system rests firmly against the backrest. Wherever possible, adapt the backrest angle of all the relevant seat backrests and adjust the seats correctly. Make sure that the seats and their backrests are correctly engaged or locked. If possible, adjust the height of the head restraints, or remove them.

WARNING

If child restraint systems and their attachment systems have been damaged or subjected to stresses in an accident, their protective function may be limited or may fail completely. A child might not be adequately restrained, for example in the event of an accident, braking or evasive action. There is a risk of injury or even death.

Do not continue to use child restraints which are damaged or have been subjected to stresses in an accident.

If attachment systems have been damaged or subjected to stresses in an accident, have them checked and replaced by a Service Partner of the manufacturer, another qualified Service Partner or a specialist workshop.

Before installation

Make sure rear seat backrests are locked in place before fitting child restraints.

Move rear seats to rearmost position to make it easier to fit child restraint.

For Australia/New Zealand: installation of child restraints

Please note the following warning because your vehicle has been equipped with a front airbag for the front passenger's seat that cannot be deactivated:



It is recommended not to use any kind of child restraint system on the front passenger's seat.

⚠ Extreme hazard

Do not use a rearward-facing child restraint on a seat protected by an airbag in front of it.

Not for Australia/New Zealand: On the front passenger seat

Deactivating airbags

⚠ WARNING

Active front passenger airbags can injure a child in a child restraint system when they deploy. There is a danger of injury. Make sure that the front passenger airbags are deactivated and the PASSENGER AIRBAG OFF indicator lamp is illuminated.

Before fitting a child restraint on the front passenger seat, make sure that the front and side airbags on the passenger side are disabled.

Deactivating the front passenger airbags with key switch, see page 154.

Rearward-facing child restraint systems

⚠ DANGER

If triggered, active front passenger airbags can fatally injure a child in a child restraint system which is mounted facing backwards. There is a risk of injury or even death. Make sure that the front passenger airbags are deactivated and the PASSENGER AIRBAG OFF indicator lamp is illuminated.



Follow the information on the front passenger sun visor.

Never use a rearward-facing child restraint on a seat protected by an active airbag in front of it, as death or serious injury to the child can occur.

Seat position and height

After installing a universal child restraint system, move the front passenger seat as far back as it will go and, if possible, adjust it to the highest position to achieve the best possible routing of the belt and protection in the event of an accident.

If the upper attachment point of the seat belt is located ahead of the child seat's belt guide, carefully move the front passenger seat forwards until the best possible belt guidance is achieved.

Backrest width

With adjustable backrest width: before fitting a child restraint system on the front passenger seat, fully open the backrest width. Do not

change the backrest width from this point on and do not call up a memory position.

ISOFIX child safety seat fasteners

General

Please comply with the operating and safety instructions provided by the child restraint system manufacturer when attaching and using ISOFIX child restraint systems.

Suitable ISOFIX child restraint systems

Only certain ISOFIX child restraints may be used in the seats intended for this purpose. The corresponding size class and size category are denoted by a letter or ISO reference on a plate on the child seat.

Information about which child restraint systems can be used on the seats in question and if the child restraint systems are suitable for or comply with ISOFIX can be found under: Suitable seats for child restraint systems, see page 102.

Fixtures for lower ISOFIX anchors

General

Observe the following when attaching child restraint systems with an integrated strap to the lower ISOFIX anchors:

Do not exceed the total weight of the child and child restraint system of 33 kg, 73 lbs.

Safety notes



WARNING

If the ISOFIX child restraint systems are not engaged correctly, the protective effect of the ISOFIX child restraint systems will be limited. There is a risk of injury or even death. Make sure the lower anchor point has engaged correctly and the ISOFIX child restraint system rests firmly against the backrest.

WARNING

The attachment points for child restraint systems in the vehicle are intended for attaching child restraint systems only. The mounting points can be damaged if other objects are attached. There is a risk of injury or material damage. Only attach child restraint systems to the corresponding attachment points.

Rear seat: Position

Symbol	Meaning
	The corresponding symbol shows the fixtures for the lower ISOFIX anchors.
	
	

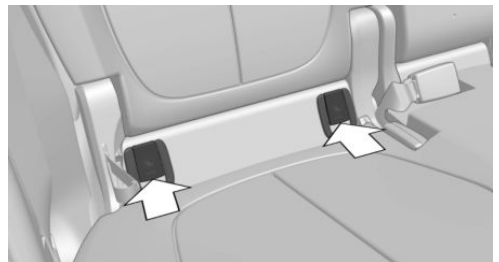

The fixtures for the lower ISOFIX anchors are located behind the marked covers.

Not for Australia/New Zealand: Front passenger seat

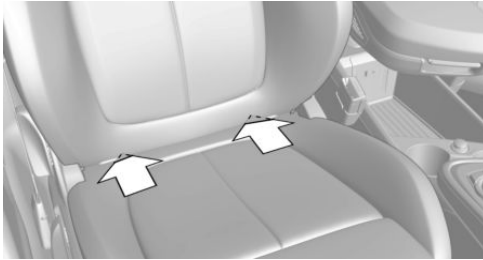

The fixtures for the lower ISOFIX anchors are located in the gap between the seat and backrest.

Before fitting ISOFIX child restraints

Pull the seat belt away from the area of the child seat mountings.

Fitting ISOFIX child restraint systems

1. Install the child restraint system, see the manufacturer's instructions.
2. Make sure that both ISOFIX anchors are engaged correctly.

Fixtures for the upper retaining strap

Safety notes

WARNING

If the upper retaining strap is used incorrectly on the child restraint system, the protective effect will be reduced. There is a danger of injury. Make sure that the upper retaining strap is not twisted and is not routed to the upper mounting point over sharp edges.

WARNING

If the rear seat backrest is not locked, the protective effect of the child restraint system will be limited or lost. The rear seat backrest can fold forward in certain situations, for example when braking or in the event of an accident. There is a risk of injury or even death. Make sure that the rear seat backrests are locked.

WARNING

The attachment points for child restraint systems in the vehicle are intended for attaching child restraint systems only. The mounting points can be damaged if other objects are attached. There is a risk of injury or material damage. Only attach child restraint systems to the corresponding attachment points.

Mounting points



The symbol shows the mounting point for the upper retaining strap.

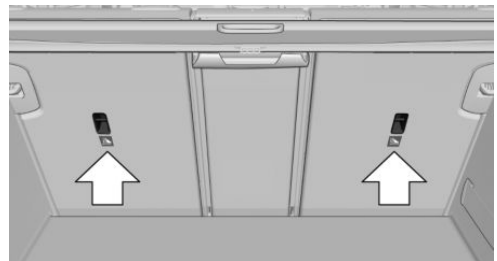

There are two mounting points for the upper retaining strap of ISOFIX child restraint systems.

Routing the retaining strap

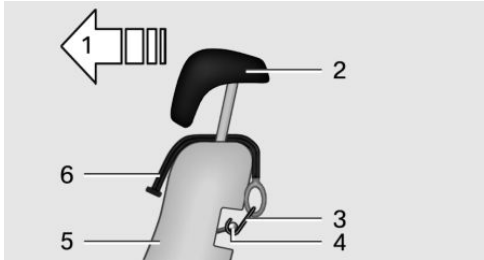

- 1 Direction of travel
- 2 Head restraint
- 3 Hook for the upper retaining strap
- 4 Mounting point
- 5 Seat backrest
- 6 Upper retaining strap

Attaching the upper retaining strap to the mounting point

WARNING

In the event of an accident, persons sitting in the rear can come in contact with the tensioned retaining strap of the child restraint system on the front passenger seat. There is a risk of injury or even death. Do not transport persons on the rear seat behind the front passenger seat if a child restraint system is mounted.

1. Raise head restraint if necessary.
2. On the rear seat: Guide the upper retaining strap between or along both sides of the head restraint mounts to the mounting point.
3. Guide the retaining strap between the seat backrest and the luggage compartment cover.
4. Attach the hook of the retaining strap to the mounting point.
5. Tighten the retaining strap by pulling it firmly down.
6. Push the head restraint down if necessary and engage it in place.

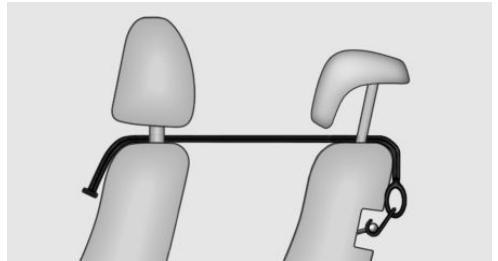

Not for Australia/New Zealand – Front passenger seat: guide the upper retaining strap between the head restraint mounts on the front passenger seat and the rear seat on the passenger side. If the vehicle is equipped with an integrated head restraint: guide the upper retaining strap over the head restraint.

Suitable seats for child restraint systems

General

The legal provisions determining which child seat is permitted for which age and body size may vary from country to country. Please comply with the relevant national legal provisions.

Additional information is available from a Service Partner of the manufacturer or another qualified Service Partner or a specialist workshop.

Detailed information on the use of child restraint systems can be found under Seats for child restraint systems, see page 324.

Seats and child restraint systems

The following section provides information on which child restraint system is suitable for which seat in the vehicle.

Left-hand drive vehicles, seats:

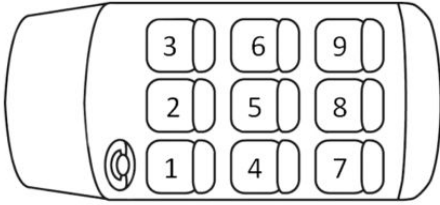

Seat	Airbag, front passenger	Fastening			
1		X			
3 - a)	ON	X			
	OFF	U	L		
4, 6 - b)		U	L		
5		X			









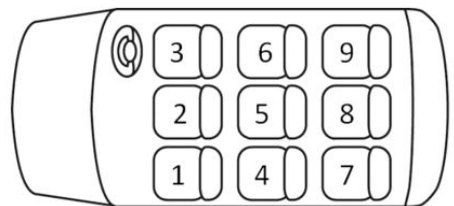

a) Adapt the forward/back position of the front passenger seat and, if necessary, move it to the high-position to achieve the best possible belt fit.

b) When using child seats on the rear seats, if necessary adjust the forward/back position of the front seat and adjust or remove the head restraint of the rear seat. If necessary, adjust the angle of the rear seat backrest to achieve the best possible belt fit.







c) Depending on the equipment or national-market version.

Right-hand drive vehicle, seats:



Seat	Airbag, front passenger	Fastening			
1 -a)	ON				
	OFF				
				e)	
3					
4, 6 - b)					
5 - c, d)					

- a) Adapt the forward/back position of the front passenger seat and, if necessary, move it to the highest position to achieve the best possible belt fit.
- b) When using child seats on the rear seats, if necessary adjust the forward/back position of the front seat and adjust or remove the head restraint of the rear seat.
- c) Only occupy the outer seats if the belt buckles are easily accessible.
- d) The seat is not suitable for child seats with a support stand.
- e) Depending on the equipment or national-market version.

Symbol	Meaning	Symbol	Meaning
	Not suitable for child restraint systems.		Suitable for ISOFIX child restraint systems.
	Suitable for Universal-category child restraint systems approved for use in this weight group.		Suitable for ISOFIX and i-Size child restraint systems.
	Suitable for child restraint systems in the Semi-Universal category if the vehicle and the seat are listed in the list of vehicle models from the manufacturer of the child restraint system.		Suitable for child restraint systems with an upper retaining strap.

Recommended child seats

Please comply with the operating and safety instructions provided by the child restraint system

manufacturer when selecting, attaching and using child restraint systems.

- ▶ Maxi-Cosi CabrioFix.
- ▶ Maxi-Cosi FamilyFix base.

- ▷ Römer TRIFIX 2.
- ▷ Römer KIDFIX series.

For Australia/New Zealand: Child restraints

General

In accordance with ADR 34/03, provisions have been made to allow installation of a child restraint system at each rear seat position.

The anchoring hooks which belong to the upper restraining strap of the child restraint - AS 1754, can be applied immediately to the relevant mounting.

Please refer strictly to the installation instructions supplied with the child restraint system.

Each seating position is fitted with a head rest.

Safety notes

⚠ WARNING

Child restraint anchorages are designed to withstand only those loads imposed by correctly fitted child restraints. Under no circumstances are they to be used for adult seat belts, harnesses or for attaching other items or equipment to the vehicle. After using and removing child restraints, fold away the anchor brackets if necessary.

⚠ WARNING

If the upper retaining strap is used incorrectly on the child restraint system, the protective effect will be reduced. There is a danger of injury. Make sure that the upper retaining strap is not twisted and is not routed to the upper mounting point over sharp edges.

⚠ WARNING

If the rear seat backrest is not locked, the protective effect of the child restraint system will be limited or lost. The rear seat backrest can fold forward in certain situations, for example when braking or in the event of an accident. There is a risk of injury or even death. Make sure that the rear seat backrests are locked.

Mounting points



The symbol shows the mounting point for the upper retaining strap.

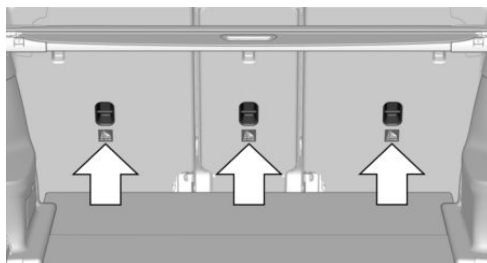

There are three mounting points for child restraint systems with an upper retaining strap.

Routing the retaining strap

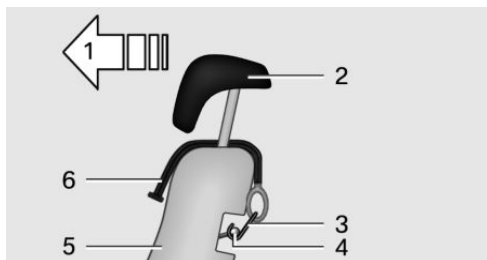

- 1 Direction of travel
- 2 Head restraint
- 3 Hook for the upper retaining strap
- 4 Mounting point

- 5 Seat backrest
- 6 Upper retaining strap

Various functions are disabled and cannot be operated in the rear.

Attaching the upper retaining strap to the mounting point

1. Raise head restraint if necessary.
2. Guide the upper retaining strap between the head restraint mounts.
3. Guide the retaining strap between the seat backrest and the luggage compartment cover.
4. Attach the hook of the retaining strap to the mounting point.
5. Tighten the retaining strap by pulling it firmly down.
6. Push head restraint down if necessary and lock it in place.

Securing doors and windows in the rear

Rear doors

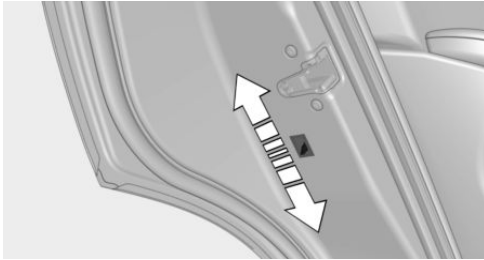

Push up the locking levers on the rear doors.

The door in question can now only be opened from the outside.

Safety switch for the rear



Press the button on the driver's door.

The LED is illuminated when the safety function is switched on.

Driving

Vehicle equipment

This chapter describes all standard, country-specific and optional equipment available for the model series. It may therefore describe equipment and functions which are not installed in your vehicle, for example on account of the optional equipment selected or the national-market version. This also applies to safety-relevant functions and systems. Please comply with the relevant laws and regulations when using the corresponding functions and systems.

Start/Stop button

Principle



The ignition is switched on or off and the engine is started by pressing the Start/Stop button.

Steptronic transmission: the engine starts if the brakes are applied when the Start/Stop button is pressed.

Manual transmission: the engine starts if the clutch pedal is pressed when pressing the Start/Stop button.

Ignition on

Steptronic transmission: press the Start/Stop button again without pressing the brake pedal.

Manual transmission: press the Start/Stop button, do not press the clutch pedal.

All systems are operational.

Most of the indicator and warning lamps in the instrument cluster illuminate for varying lengths of time.

To save battery power when the engine is off, switch off the ignition and any unnecessary power consumers.

Ignition off

Steptronic transmission: press the Start/Stop button again without pressing the brake pedal.

Manual transmission: press the Start/Stop button again, do not press the clutch pedal.

All indicator lamps in the instrument cluster extinguish.

To save battery power when the engine is off, switch off the ignition and any unnecessary power consumers.

Safety measures

If the vehicle is stationary with the engine switched off, the ignition switches off automatically under the following circumstances:

- ▷ When the vehicle is locked, even if the low-beam headlights are switched on.
- ▷ Shortly before the battery is discharged so that an engine start remains possible.
- ▷ When opening or closing the driver's door, if the driver's seat belt is unfastened and the low-beam headlights are switched off.
- ▷ When the driver's seat belt is unfastened, if the driver's door is open and the low-beam headlights are switched off.
- ▷ When opening the front doors, if there is no other person on the front seats.

After some minutes without further operation, the low-beam headlights are changed over to side lights.

Steptronic transmission with a tap-operated selector lever, see page 120: when the ignition is switched off, the selector lever will shift automatically to position P if it was previously in position R, D or M/S.

Radio-ready state

General

In the radio-ready state, individual current consumers remain ready for operation.

Activating

When the engine is running, press the Start/Stop button.

If engine is switched off and the ignition is switched on: the system automatically activates radio-ready state when the door is opened if the lights are switched off or the daytime running lights are switched on.

Radio-ready state remains active when ignition is switched off automatically, such as for the following reasons:

- ▷ When the driver's door is opened or closed.
- ▷ When the driver's seat belt is unfastened.
- ▷ When the low-beam headlights are automatically switched to side lights.

Switching off automatically

The radio-ready state is automatically switched off in the following situations:

- ▷ When the driver's or front passenger door is opened when exiting the vehicle, with the engine stopped manually.
- ▷ If the ignition is switched off manually with the Start/Stop button.
- ▷ After approximately 8 minutes.
- ▷ When locking via the central locking system.
- ▷ Shortly before the battery is discharged so that an engine start remains possible.

Engine start

Safety notes

DANGER

A blocked exhaust pipe or inadequate ventilation can allow harmful exhaust fumes to enter the vehicle. The exhaust fumes contain pollutants which are colourless and odourless. In enclosed spaces, exhaust fumes can also build up outside the vehicle. There is a risk of death. Keep the exhaust pipe clear and ensure sufficient ventilation.

WARNING

An unsecured vehicle can start moving and rolling away. There is a risk of accident. Before leaving the vehicle, secure it to prevent it from rolling away.

Observe the following to ensure that the vehicle is secured against rolling away:

- ▷ Apply the parking brake.
- ▷ Turn the front wheels towards the kerb on upward or downward gradients.
- ▷ Additionally secure the vehicle on upward or downward gradients, for example with a chock.

NOTE

Repeated attempts to start the engine or starting it several times in quick succession can cause the starter to overheat. Fuel will also be unburned or insufficiently burned, which could cause the catalytic converter to overheat. There is a risk of material damage. Avoid repeatedly starting in quick succession.

Diesel engine

With the engine cold and at temperatures below 0 °C, 32 °F the starting operation can be delayed slightly due to automatic preheating.

A Check Control message is shown.

Full drive power may not be available until the engine is at operating temperature. Observe the engine temperature display for this. In this case, the vehicle will not accelerate in the usual way.

Petrol engine

Depending on the engine version, full drive power may only be available approx. 30 seconds after starting the engine. In this case, the vehicle will not accelerate in the usual way.

Steptronic transmission

Starting the engine

1. Press the brake.
2. Press the Start/Stop button.

The starting process runs automatically for a short time and stops as soon as the engine starts.

Manual transmission

Starting the engine

1. Press the brake.
2. Press the clutch and engage idle position.
3. Press the Start/Stop button.

The starting process runs automatically for a short time and stops as soon as the engine starts.

Stopping the engine

Safety notes

WARNING

Unsupervised children or pets in the vehicle can set the vehicle in motion and endanger themselves or other road users, for example by the following actions:

- ▷ Pressing the Start/Stop button.
- ▷ Releasing the parking brake.
- ▷ Opening and closing doors or windows.
- ▷ Engaging selector lever position N.
- ▷ Operating vehicle equipment.

There is a risk of accident or injury. Do not leave children or pets unsupervised in the vehicle. When leaving the vehicle, take the vehicle key with you and lock the vehicle.

WARNING

An unsecured vehicle can start moving and rolling away. There is a risk of accident. Before leaving the vehicle, secure it to prevent it from rolling away.

Observe the following to ensure that the vehicle is secured against rolling away:

- ▷ Apply the parking brake.
- ▷ Turn the front wheels towards the kerb on upward or downward gradients.
- ▷ Additionally secure the vehicle on upward or downward gradients, for example with a chock.

Steptronic transmission

Stopping the engine

1. Apply the parking brake when the vehicle is stationary.
2. Engage selector lever position P.

- Press the Start/Stop button.
The engine is switched off.
The radio-ready state is switched on.

Manual transmission

Stopping the engine

- Press the Start/Stop button when the vehicle is at standstill.
- Engage first gear or reverse.
- Apply the parking brake.

Automatic Start/Stop function

Principle

The Auto Start Stop function helps you to save fuel. The system switches the engine off when stationary, for example in congestion or at traffic lights. The ignition remains switched on. For driving off, the engine starts automatically.

General

Each time the engine is started via the Start/Stop button, the Automatic Start/Stop function is switched to standby.

The function is activated from a speed of around 5 km/h, 3 mph.

Depending on selected drive mode, the system is activated or deactivated automatically.

Stopping the engine

Operating requirements

The engine is automatically shut down when stationary under the following conditions:

Steptronic transmission:

- Selector lever in selector lever position D.
- Brake pedal remains pressed while the vehicle is at a standstill.

- Driver's seat belt buckled or driver's door closed.

To be able to release the brake pedal when the vehicle is stationary, engage the selector lever in the P position. The engine remains switched off.

Press the brake pedal to continue driving. The engine starts automatically when a gear is engaged.

Manual transmission:

- Gearbox in neutral and clutch pedal not pressed.
- Driver's seat belt buckled or driver's door closed.

The air flow rate of the air conditioning system is reduced when the engine is not running.

Steptronic transmission: manual engine stop

Depending on the equipment and national-market version, the engine can be switched off manually, if the engine was not switched off automatically when the vehicle came to a stop:

- Rapidly press the brake pedal from the current position.
- Engage selector lever position P.

If all the operating requirements have been met, the engine is shut down.

Displays in the instrument cluster



The READY display in the revolution counter indicates that the Automatic Start/Stop function is ready for automatic engine starting.



The display indicates that the preconditions for an automatic engine stop are not met.

Functional limitations

The engine is not shut down automatically in the following situations, for example:

- ▷ On steep downward gradients.
- ▷ Outside temperature too low.
- ▷ High outside temperature and operation of the automatic air conditioning.
- ▷ Interior not heated or cooled to the desired temperature.
- ▷ Engine is not yet at operating temperature.
- ▷ Sharp steering angle or steering operation.
- ▷ After reversing.
- ▷ Where there is a risk of condensation when the automatic air conditioning is switched on.
- ▷ Vehicle battery is heavily discharged.
- ▷ At high altitudes.
- ▷ Bonnet is unlocked.
- ▷ Park Assist is activated.
- ▷ Stop-and-go traffic.
- ▷ Selector lever position in N, M/S or R.
- ▷ Use of fuel with high ethanol content.

Engine start

For driving off, the engine automatically starts under the following conditions:

- ▷ Steptronic transmission: by releasing the brake pedal.
- ▷ Manual transmission: by depressing the clutch pedal.

After starting the engine, accelerate as normal.

Safety function

After an automatic shut down, the engine will not restart automatically, if one of the following conditions is met:

- ▷ Driver's seat belt unbuckled and driver's door open.
- ▷ Bonnet has been unlocked.

Several indicator lamps illuminate for various lengths of time.

The engine can only be started using the Start/Stop button.

Functional limitations

Even if you do not want to drive off, the engine restarts automatically in the following situations:

- ▷ Very high temperature in the interior when the cooling function is switched on.
- ▷ When the steering wheel is turned.
- ▷ Steptronic transmission: shift from selector lever position D to N, R or M/S.
- ▷ Steptronic transmission: shift from selector lever position P to N, D, R or M/S.
- ▷ Vehicle starts to roll.
- ▷ Where there is a risk of condensation when the automatic air conditioning is switched on.
- ▷ Vehicle battery is heavily discharged.
- ▷ Very low temperature in the interior when the heating is switched on.
- ▷ Low brake vacuum, for example because the brake pedal has been pressed a number of times in succession.

Automatic Start/Stop additional function

Depending on the equipment and national-market version, the vehicle has various sensors to record the traffic situation. This enables the Automatic Start/Stop function to adapt to various traffic situations and, where necessary, behave in an anticipatory manner.

For example, in the following situations:

- ▷ If a situation is detected in which the duration of the stop is likely to be very short, the engine is not stopped automatically. Depending on the situation, a message is shown on the control display.
- ▷ If a situation is detected in which the vehicle should drive off immediately, the stopped engine is started automatically.

The function may be limited if the navigation data is invalid, outdated or not available, for example.

Manually deactivating/activating the system

Using the button

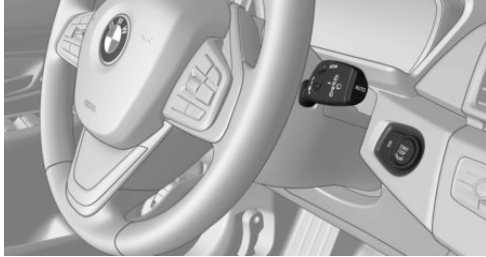

Press the button.

- ▷ LED illuminates: Automatic Start/Stop function is deactivated.
During an automatic engine stop, the engine is started.
The engine can be started or stopped only by means of the Start/Stop button.
- ▷ The LED is extinguished: Automatic Start/Stop function is activated.

Parking the vehicle during automatic engine stop

During an automatic engine stop, the vehicle can be parked safely, for example in order to leave it.

Steptronic transmission:

1. Engage selector lever position P.
2. Press the Start/Stop button. The ignition is switched off. The Automatic Start/Stop function is deactivated.
3. Apply the parking brake.

Manual transmission:

1. Press the Start/Stop button. The ignition is switched off. The Automatic Start/Stop function is deactivated.

2. Engage first gear or reverse.
3. Apply the parking brake.

Start engine as usual, using the Start/Stop button.

Automatic deactivation

In certain situations the Automatic Start/Stop function is deactivated automatically for safety reasons, for example if the absence of the driver is detected.

Malfunction

The Automatic Start/Stop function no longer shuts down the engine automatically. A Check Control message is shown. It is possible to keep driving. Have the system checked by a Service Partner of the manufacturer or another qualified Service Partner or a specialist workshop.

Parking brake

Principle

The parking brake is used to prevent the vehicle from rolling when it is parked.

Safety notes

WARNING

An unsecured vehicle can start moving and rolling away. There is a risk of accident. Before leaving the vehicle, secure it to prevent it from rolling away.

Observe the following to ensure that the vehicle is secured against rolling away:

- ▷ Apply the parking brake.
- ▷ Turn the front wheels towards the kerb on upward or downward gradients.
- ▷ Additionally secure the vehicle on upward or downward gradients, for example with a chock.

⚠ WARNING

Unsupervised children or pets in the vehicle can set the vehicle in motion and endanger themselves or other road users, for example by the following actions:

- ▷ Pressing the Start/Stop button.
- ▷ Releasing the parking brake.
- ▷ Opening and closing doors or windows.
- ▷ Engaging selector lever position N.
- ▷ Operating vehicle equipment.

There is a risk of accident or injury. Do not leave children or pets unsupervised in the vehicle. When leaving the vehicle, take the vehicle key with you and lock the vehicle.

Overview

 Parking brake

Engaging**When the vehicle is stationary**

 Pull the switch.
The LED is illuminated.

 The indicator lamp illuminates red. The parking brake is engaged.

The parking brake may be applied automatically depending on the parking situation.

Steptronic transmission: in some parking situations, the parking brake is automatically applied when selector lever position P is engaged. In these cases, the parking brake is automatically disengaged when shifting from selector lever position P.

While the vehicle is in motion

The parking brake can be used as an emergency brake while driving:

Pull and hold the switch. The vehicle brakes hard for as long as the switch is pulled.



The indicator lamp illuminates red, a signal sounds and the brake lights illuminate.

A Check Control message is shown.

If the vehicle is braked to a standstill, the parking brake is applied.

Releasing**Releasing manually**

1. Switch on the ignition.
2.  Manual transmission: press the button with the brakes applied.



Steptronic transmission: press the switch with the brakes applied or selector lever position P engaged.

The LED and indicator lamp are illuminated.
The parking brake is released.

Automatic release with Steptronic transmission

Depress the accelerator pedal to release automatically.

The LED and indicator lamp are illuminated.

The parking brake is automatically released by operating the accelerator pedal if the following conditions are met:

- ▷ Engine on.

- ▷ Drive position engaged.
- ▷ Driver's seat belt fastened and door closed.

Automatic release with manual gearbox

Drive off as usual. The parking brake is released when the clutch pedal is released.

The LED and indicator lamp are illuminated.

Under the following preconditions, the parking brake is released automatically:

- ▷ Engine on.
- ▷ Gear engaged.
- ▷ Driver's seat belt fastened and door closed.
- ▷ Engine power is sufficient to start off.

Malfunction

If the parking brake has failed or malfunctioned, secure the vehicle to prevent it from rolling away before leaving the vehicle.

A Check Control message is shown.

After getting out, secure the vehicle to prevent it from rolling away, for example with a chock.

After a power failure

Initial operation

1. Switch on the ignition.
2.  Press the switch with the brakes applied or selector lever position P engaged.

It may take a few seconds to restore parking brake functionality. Any sounds that occur are normal.



The indicator lamp in the instrument cluster extinguishes when the parking brake is operational again.

Turn indicators, high-beam headlights, headlight flasher

Turn indicator

Turn indicator in exterior mirror

Do not fold in the exterior mirrors while driving or while operating the turn indicators or hazard warning lights to ensure that the indicator lamps in the exterior mirrors are well recognisable.

Indicating

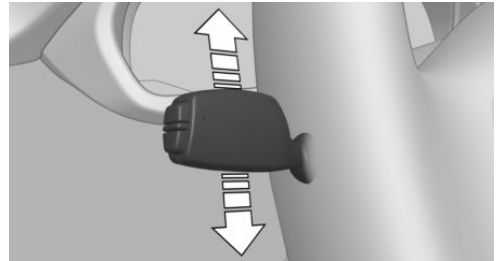

Press the lever beyond the resistance point.

The lever returns to its initial position after activation. To cancel the signal manually, press the lever gently as far as the resistance point.

Triple turn signal

Briefly press the lever up or down. The turn indicator flashes three times.

This function can be enabled or disabled.

Via iDrive:

1. "My Vehicle"
2. "Vehicle settings"
3. "Lights"
4. "Exterior lighting"
5. "One-touch turn signal"
6. Select the desired setting.

The setting is saved for the current profile.

Indicating a turn briefly

Press the lever as far as the resistance point and hold it there for as long as you wish to indicate a turn.

Malfunction

If the indicator lamp flashes more rapidly than usual, a turn indicator bulb has failed.

When towing a trailer, the light might also indicate failure of one of the turn signal lights of the trailer.

High-beam headlights, headlight flasher

Push the lever forwards or pull it back.

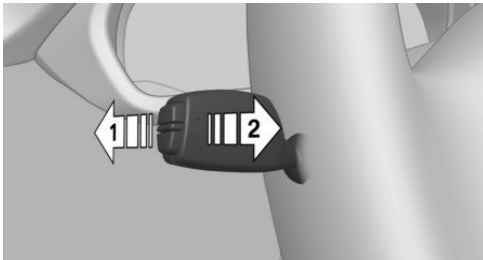

- ▶ High-beam headlights on, arrow 1.
The high-beam headlights are illuminated when the low-beam headlights are switched on.
- ▶ High-beam headlights off/headlight flasher, arrow 2.

Wiper system

General

Do not use the wipers on a dry windscreen, otherwise the wiper blades will wear or become damaged more quickly.

Safety notes

WARNING

If the wipers start moving when they are folded away from the windscreen, parts of the body may become trapped or the vehicle may be damaged. There is a risk of injury or material damage. Make sure that the vehicle is switched off when the wipers are folded away from the windscreen, and that the wipers are in contact with the windscreen when switching on.

NOTE

If the wipers are frozen to the windscreen, switching them on may cause the wiper blades to tear off and the wiper motor to overheat. There is a risk of material damage. Defrost the windscreen before switching on the wipers.

Switching on

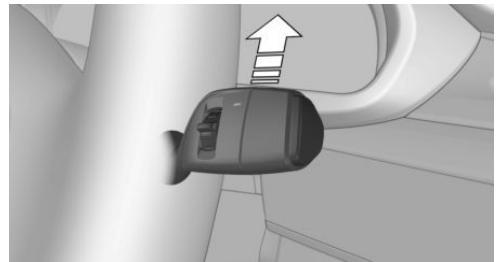

Tap the lever up or push it beyond the resistance point.

- ▶ Normal wiping speed: tap up once.
When the vehicle is at a standstill, the wipers switch to intermittent mode.
- ▶ Fast wiping speed: press upwards twice or press once beyond the resistance point.
When the vehicle is at a standstill, the wipers switch to normal speed.

The lever returns to the base position when released.

Switching off and flick-wiping

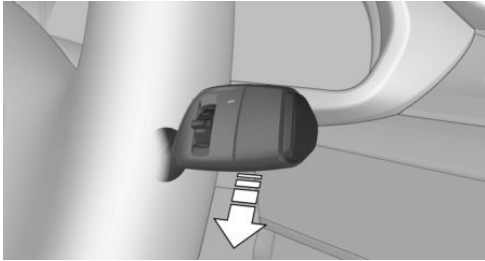

Press the lever down.

- ▶ To switch off fast wiping speed: press downwards twice.
- ▶ To switch off normal wiping speed: press downwards once.
- ▶ To flick-wipe: press downwards once.

The lever returns to the base position when released.

Intermittent mode or rain sensor

Principle

The rain sensor automatically controls the wiper operation depending on the level of rainfall.

General

The sensor is mounted on the windscreen, directly in front of the interior mirror. Without rain sensor, the interval for the wiper operation is pre-set.

Safety note

NOTE

In car washes, the wipers may inadvertently start moving if the rain sensor is activated. There is a risk of material damage. Deactivate the rain sensor in car washes.

Activating/deactivating

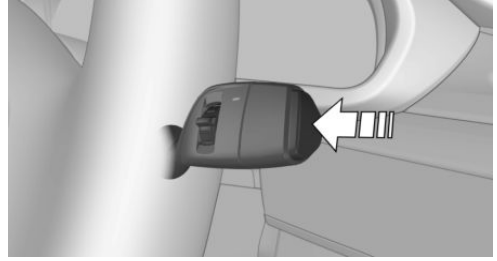

Press the button on the wiper lever.

Wiping is started.

If a rain sensor is fitted: the LED in the wiper lever is illuminated.

If there is frost, wiping may not start.

If the journey is interrupted when the rain sensor is switched on: if the journey is continued within about 15 minutes, the rain sensor is reactivated automatically.

Setting the interval time or sensitivity of the rain sensor

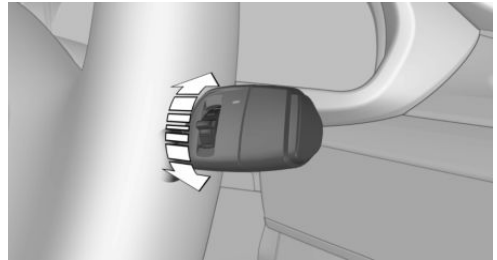

Turn the knurled wheel.

If the rain sensor is deactivated: set the interval time.

If the rain sensor is activated: set the sensitivity of the rain sensor.

Up: short interval or high sensitivity of the rain sensor.

Down: long interval or low sensitivity of the rain sensor.

Windscreen washer

Safety notes

⚠ WARNING

At low temperatures, the washer fluid can freeze onto the windscreen and restrict visibility. There is a risk of accident. Only use the washer systems if there is no possibility of the washer fluid freezing. Use antifreeze if required.

⚠ NOTE

If the washer fluid reservoir is empty, the washer pump cannot operate as intended. There is a risk of material damage. Do not use the washer system with the washer fluid reservoir empty.

Cleaning the windscreen

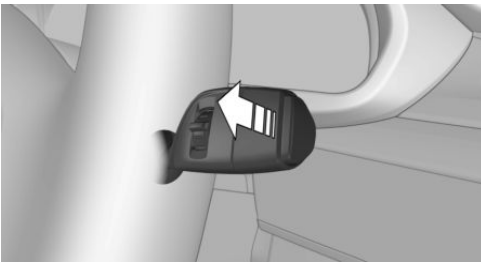

Pull the lever.

Fluid from the washer fluid reservoir is sprayed onto the windscreen and the wipers are operated briefly.

Windscreen washer jets

Both windscreen washer jets are automatically heated when the ignition is switched on.

Rear window wiper

Overview

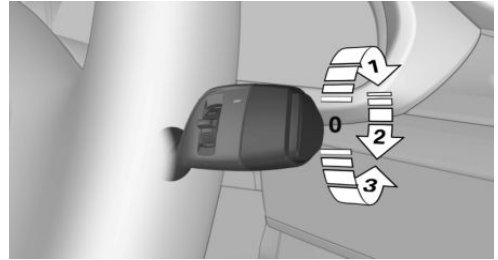

Switching on

Turn the outer switch upwards.

- ▷ Park position of the wiper, position 0.
- ▷ Intermittent mode, arrow 1. Engaging reverse gear activates continuous operation.

Cleaning the rear window

Turn the outer switch in the desired direction.

- ▷ In wiper park position: turn the switch downwards, arrow 3. The switch returns to the park position when released.
- ▷ In intermittent mode: turn the switch further, arrow 2. The switch returns to the intermittent position when released.

The function is deactivated if the washer fluid level in the reservoir is low.

Fold-out position of the wipers

Principle

In the fold-out position, the wipers can be folded away from the windscreen.

General

This is necessary for example when replacing the wiper blades or to keep them away from the windscreen when there is frost.

Safety notes

WARNING

If the wipers start moving when they are folded away from the windscreen, parts of the body may become trapped or the vehicle may be damaged. There is a risk of injury or material damage. Make sure that the vehicle is switched off when the wipers are folded away from the windscreen, and that the wipers are in contact with the windscreen when switching on.

NOTE

If the wipers are frozen to the windscreen, switching them on may cause the wiper blades to tear off and the wiper motor to overheat. There is a risk of material damage. Defrost the windscreen before switching on the wipers.

Folding out the wipers

1. Switch the ignition on and back off again.
2. If there is a risk of frost, make sure that the wiper blades are not frozen to the windscreen.
3. Press the wiper lever upwards beyond the resistance point and hold it there for approximately 3 seconds until the wipers stop in an approximately vertical position.
4. Lift the wipers completely away from the windscreen.

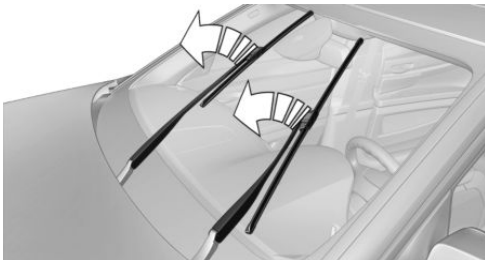

Folding in the wipers

After folding the wipers in, the wiper system must be reactivated.

1. Fold the wipers fully down onto the windscreen.
2. Switch on the ignition.
3. Press the wiper lever downwards. The wipers move back to the rest position and are operational once again.

Washer fluid

General

All washer jets are supplied from one reservoir. Use a mixture of tap water and screenwash concentrate for the windscreen washer system, if necessary with the addition of antifreeze.

Recommended minimum fill level: 1 litre, 1.7 Imp. pints.

Safety notes

WARNING

Some antifreezes can contain toxic substances, and are flammable. There is a risk of fire and injury. Please comply with the instructions on the containers. Keep antifreezes away from sources of combustion. Do not pour operating fluids into other bottles. Keep operating fluids out of the reach of children.

WARNING

Washer fluid can ignite on contact with hot parts of the engine and catch fire. There is a risk of injury or material damage. Only top up washer fluid when the engine has cooled down. Afterwards fully close the cap of the washer fluid reservoir.

NOTE

Silicone additives mixed with the washer fluid for their water beading effect on the windows may damage the washer system. There is a risk of material damage. Do not add silicone additives to the washer fluid.

NOTE

Mixing different screenwash concentrates or antifreezes may damage the washer system. There is a risk of material damage. Do not mix different screenwash concentrates or antifreezes. Please comply with the instructions and mixing ratios stated on the containers.

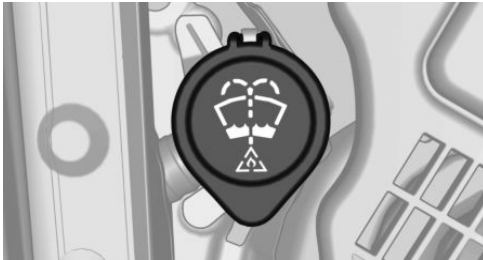
Overview

The reservoir for the washer fluid is located in the engine compartment.

Malfunction

Using undiluted screenwash concentrate or anti-freeze based on alcohol may result in false readings at low temperatures below -15 °C/+5 °F.

Manual transmission**Safety notes****WARNING**

An unsecured vehicle can start moving and rolling away. There is a risk of accident. Before leaving the vehicle, secure it to prevent it from rolling away.

Observe the following to ensure that the vehicle is secured against rolling away:

- ▷ Apply the parking brake.
- ▷ Turn the front wheels towards the kerb on upward or downward gradients.
- ▷ Additionally secure the vehicle on upward or downward gradients, for example with a chock.

NOTE

When shifting into a lower gear, high engine speeds can damage the engine. There is a risk of material damage. Push the shift lever to the right while shifting into the 5th or 6th gear.

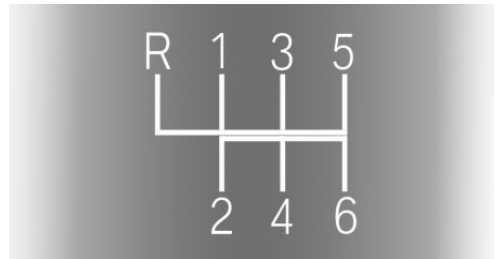
Schematic diagram

- ▷ 1 – 6: forward gears.
- ▷ R: reverse.

Shifting gears

General

Depending on the motorisation, the rotational speed is automatically adjusted as required during a gear shift for a harmonious gear change.

Reverse gear

Engage this position only when the vehicle is stationary.

To overcome the resistance, move the shift lever firmly to the left towards the left and engage the reverse gear with a gear shift movement forwards.

Rolling or pushing the vehicle

In some situations, the vehicle is to roll without its own power, for example in a car wash, or be pushed.

1. Switch on the ignition.
2. Press the clutch and change out of a forward gear or reverse.
3. Releasing the parking brake.

Steptronic transmission

Principle

The Steptronic transmission combines the functions of an automatic transmission with the opportunity of changing gear manually if required.

Safety note

WARNING

An unsecured vehicle can start moving and rolling away. There is a risk of accident. Before leaving the vehicle, secure it to prevent it from rolling away.

Observe the following to ensure that the vehicle is secured against rolling away:

- ▷ Apply the parking brake.
- ▷ Turn the front wheels towards the kerb on upward or downward gradients.
- ▷ Additionally secure the vehicle on upward or downward gradients, for example with a chock.

Selector lever version

General

Depending on the equipment, a transmission with either a latching selector lever or a tap-operated selector lever is installed.

Transmission with a latching selector lever

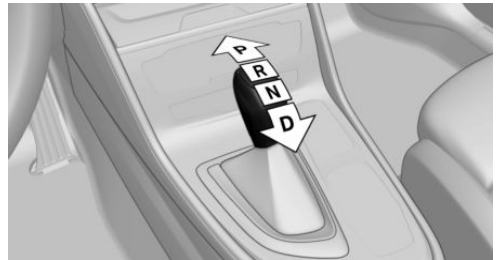

The selector lever positions P, R, N and D are selected by moving the selector lever into the respective selector lever position. The selector lever engages in the selector lever positions.

Transmission with a tap-operated selector lever

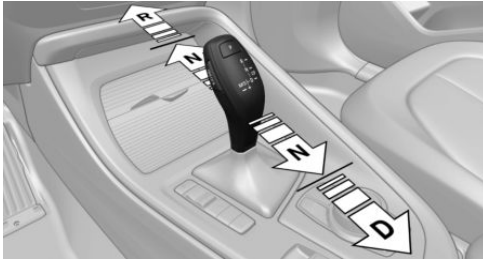

To select the selector lever positions R, N and D, tap the selector lever forwards or back. The selector lever returns to the middle position when released.

To select park, press button P on the selector lever; alternatively, it is automatically engaged, see page 121, in certain situations.

Selector lever positions

D drive position

Selector lever position for all normal driving. All gears for forward driving are selected automatically.

R Reverse

Only engage selector lever position R when the vehicle is stationary.

N neutral

In selector lever position N, the vehicle can be pushed or can roll without power from the engine, for example in car washes, see page 123.

P Park

General

Selector lever position for parking the vehicle, for example.

In selector lever position P, the transmission blocks the drive wheels.

Only engage selector lever position P when the vehicle is stationary.

Before leaving the vehicle, ensure that selector lever position P is engaged. The vehicle could otherwise start to move. Also apply the parking brake.

Automatic parking position for a transmission with a tap-operated selector lever

Selector lever position P is automatically engaged in the following situations, for example:

- ▶ After stopping the engine in the radio-ready state, see page 108, or ignition off, see page 107, when selector lever position R, D or M/S is engaged.
- ▶ If, while the vehicle is at a standstill and selector lever position D, M/S or R is engaged, the driver's seat belt is unfastened, the driver's door is opened and the brake pedal is not depressed.
- ▶ After switching off the ignition, if selector lever position N is engaged.

Engaging selector lever positions: with a latching selector lever

General

Keep the brakes applied until you are ready to drive off, otherwise the vehicle will move when a drive position is selected.

Operating requirements

The selector lever will only move from position P to another selector lever position if the ignition is switched on or the engine is running.

Engaging selector lever position D, N, R or P

With the vehicle stationary, depress the brake pedal before shifting out of selector lever position P or N, otherwise the shift lock will not be

deactivated and the shift command will not be executed.

A selector lever lock prevents the following incorrect operation:

- ▷ Inadvertent shifting to selector lever position P or R.
 - ▷ Inadvertent change from selector lever position P to another selector lever position.
1. To cancel the selector lever lock: with the brake pedal pressed, press the button on the front of the selector lever.

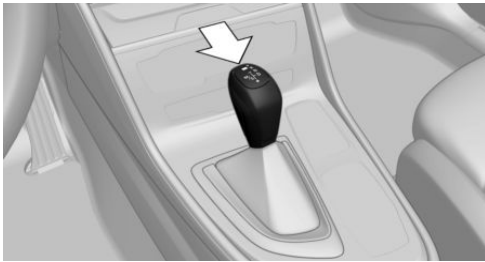

2. Move the selector lever to the desired position.

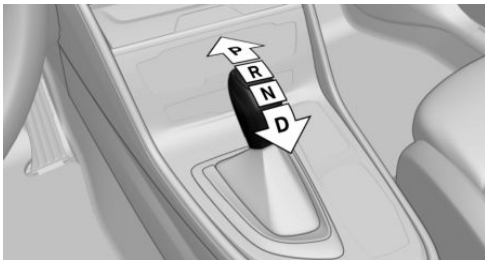

Engaging selector lever positions: with a tap-operated selector lever

General

Keep the brakes applied until you are ready to drive off, otherwise the vehicle will move when a drive position is selected.

Operating requirements

A change from selector lever position P to another selector lever position only takes place when the brake pedal is pressed.

Depending on the transmission version, the engine may have to be running too.

It may not be possible to move out of selector lever position P until all technical conditions are met.

Engaging selector lever positions D, N, R

A selector lever lock prevents the following incorrect operation:

- ▷ Inadvertent shifting to selector lever position R.
- ▷ Inadvertent change from selector lever position P to another selector lever position.

1. Fasten the driver's seat belt.
2. Press and hold the button to cancel the selector lever lock.

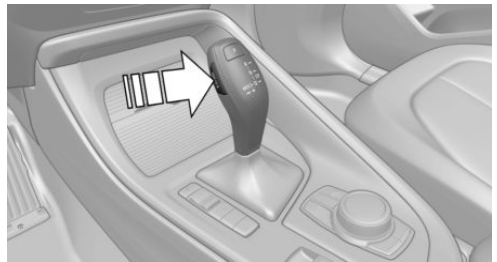

3. Briefly press the selector lever in the desired direction, possibly overcoming a resistance point. The selector lever returns to the middle position when released.



Engaging selector lever position P

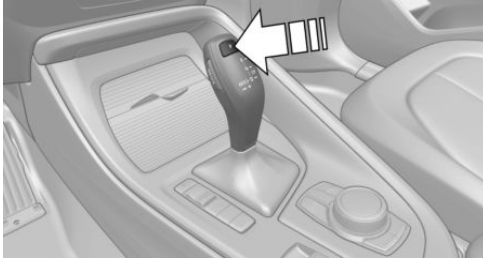

Press button P.

Rolling or pushing the vehicle

General

In some situations, the vehicle may need to be rolled a short distance without power, for example in a car wash, or may need to be pushed.

Engaging selector lever position N: with a latching selector lever

1. Switch on the ignition.
2. If necessary, release the parking brake.
3. Press the brake.
4. Operate the selector lever lock and engage selector lever position N.
5. Release the brake.

The vehicle can now roll.

If there is a fault, it may not be possible to change the selector lever position.

Unlock the transmission lockout manually, see page 125, if necessary.

Engaging selector lever position N: with a tap-operated selector lever

NOTE

Selector lever position P is automatically engaged when the ignition is switched off. There is a risk of material damage. Do not switch the ignition off in car washes.

1. Start the engine with the brakes applied.
2. If necessary, release the parking brake.
3. Press the brake.
4. Operate the selector lever lock and engage selector lever position N.
5. Stop the engine.

In this way the ignition remains switched on and a Check Control message is displayed.

The vehicle can now roll.

Irrespective of the ignition status, the selector lever position P is engaged automatically after approximately 15 minutes.

If there is a fault, it may not be possible to change the selector lever position.

Unlock the transmission lockout electronically if necessary, see page 126.

Kick-down

Kick-down is used to achieve maximum performance.

Press the accelerator pedal down beyond the regular full-throttle position; some resistance will be felt.

Sport program M/S

Principle

In the sport program, the gear shift points and gear shift times are configured for more sporty driving. For example, the transmission shifts up later and the gearshift times are shorter.

Activating the sport program

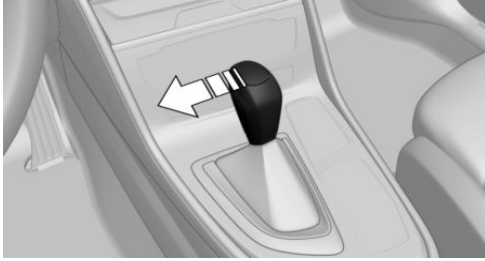

Push the selector lever out of selector lever position D to the left.

The gear selected is displayed in the instrument cluster, for example S1.

The sport program of the gearbox is activated.

Exiting sport program

Press the selector lever to the right.

D is shown in the instrument cluster.

Manual mode M/S

Principle

The gears can be changed manually in manual mode.

Activating manual mode

1. Press the selector lever from selector lever position D to the left, arrow 1.

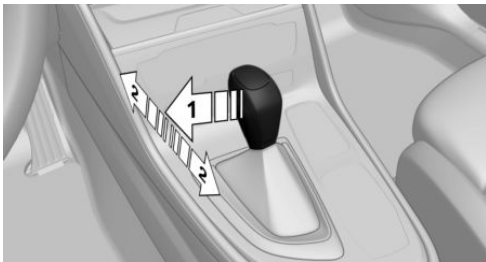

2. Press the selector lever forwards or pull it backwards, arrows 2.

Manual mode becomes active and the gear is shifted.

The gear selected is displayed in the instrument cluster, for example M1.

Shifting gears

- ▷ To shift down: press the selector lever forwards.
- ▷ To shift up: pull the selector lever backwards.

In certain situations, the transmission continues to shift automatically, for example when engine speed limits are reached.

With a tap-operated selector lever: when M2 is set manually while the vehicle is stationary, the transmission will no longer shift back to M1. This shifting behaviour is retained until you engage M1 manually or exit M.

Steptronic sport transmission: preventing automatic upshift in manual mode M/S

If certain engine speed limits are reached, it is automatically upshifted as needed in manual mode M/S.

In manual mode M/S, the Steptronic Sport transmission does not automatically shift up when certain engine speed limits are reached, if one of the following conditions is met:

- ▷ Dynamic Stability Control DSC deactivated.
- ▷ Dynamic Traction Control DTC activated.

In addition, there is no down shift for kick-down.

In the corresponding gearbox version, operating the kick-down and the left shift paddle at the same time allows you to change down to the lowest possible gear. This is not possible in a brief change from selector lever position D to manual mode M/S using the shift paddles.

Exiting manual mode

Press the selector lever to the right.

D is shown in the instrument cluster.

Shift paddles

Principle

Shift paddles on steering wheel enable fast gear-shifting without taking hands off steering wheel.

General

Gearshift

Gear shifting is only carried out if the engine speed and vehicle speed are appropriate.

Short-term manual operation

In selector lever position D, operating a shift paddle causes the system to switch to manual mode temporarily.

The gearbox reverts to automatic mode from manual mode after a certain period of time of moderate driving without acceleration or gear shifts using the shift paddles.

Changing to automatic mode is possible as follows:

- ▷ Pull and hold right shift paddle.
- ▷ In addition to briefly pulling right shift paddle, briefly pull left shift paddle.

Permanent manual mode

In selector lever position S, operating a shift paddle causes the system to switch permanently to manual mode.

Shifting gears



- ▷ Change up: pull right shift paddle briefly.

- ▷ Change down: pull left shift paddle briefly.
- ▷ Pull and hold left shift paddle to shift to the lowest possible gear.

The gear selected appears briefly on the instrument cluster, followed by the gear currently in use.

Displays in the instrument cluster



The selector lever position is displayed, for example P.

Releasing the transmission lockout manually: with a latching selector lever

If the selector lever is blocked in selector lever position P in spite of the ignition being switched on, the brake pedal depressed and button pressed on the selector lever, the transmission lockout can be released manually:

Before the transmission lockout is released manually, apply the parking brake to prevent vehicle from rolling away.

1. Release the sleeve from selector lever at the bottom from the centre console.



2. Lift the sleeve. Remove the cable plug connector as appropriate.

- With the screwdriver from the on-board tool kit, see page 290, push the yellow release lever down, arrow.

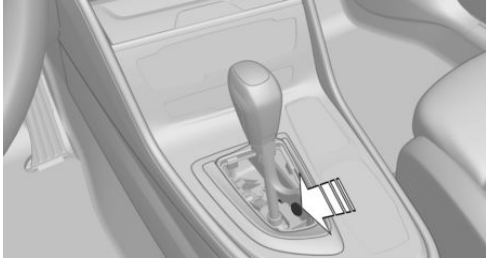

- Press the button on the front of the selector lever and move the selector lever back slightly.
Release the release lever.
- Move the selector lever to the desired position.

More information can be found in the Tow-starting and towing chapter.

Releasing the transmission lockout electronically: with a tap-operated selector lever

General

Unlock the transmission lockout electronically to manoeuvre the vehicle out of danger.

Before releasing the transmission lockout, apply the parking brake to prevent the vehicle from rolling away.

Engaging selector lever position N

Unlocking is possible if the starter is able to turn the engine.

- Apply the brakes and keep them applied.
- Press the Start/Stop button. The starter must be heard to start turning.
- Press the button on the selector lever, arrow 1, push the selector lever to selector lever position N and hold it there, arrow N,

until selector lever position N is displayed in the instrument cluster.

A Check Control message is shown.

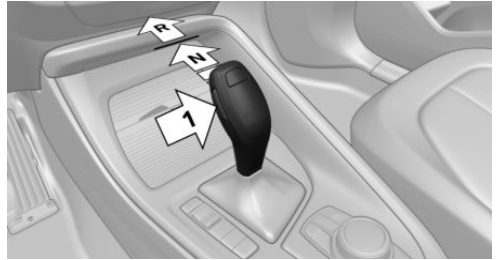

- Release the selector lever.
- Release the brake as soon as the starter stops.
- Manoeuvre the vehicle out of danger and then secure it against rolling away.

More information can be found in the Tow-starting and towing chapter.

Steptronic sport transmission: Launch Control

Principle

When the ambient conditions are dry, Launch Control permits optimised acceleration on a road surface that offers plenty of grip.

General

Use of Launch Control causes premature component wear, as the function subjects the vehicle to very high stresses and loads.

Do not use Launch Control when running in, see page 226.

To start with Launch Control, point the front wheels straight forwards.

Operating requirements

Launch Control is available as soon as the engine and transmission are at operating temperature.

Depending on the outside temperature and driving style, the engine and transmission require an

uninterrupted journey of up to 50 km, 30 miles in order to reach the operating temperature needed for Launch Control.

Starting with Launch Control

With the engine running:

-  Press the button and select SPORT with the Driving Experience Control. TRACTION is displayed in instrument cluster in combination with SPORT and DSC OFF indicator lamp is illuminated.
- Engage selector lever position S.
- Press the brake firmly with the left foot.
- Press the accelerator pedal down beyond the resistance at the full-throttle position and hold, kick-down.
A flag symbol is shown in the instrument cluster.
- The starting engine speed is adjusted. Wait briefly until the engine speed is constant. Keep the accelerator pedal in this position.
- Release the brake within 3 seconds of the flag symbol illuminating.
The vehicle accelerates.
Upshifts are automatic as long as the flag symbol is displayed and the accelerator pedal is not released.

Using again during a journey

Once Launch Control has been used, the transmission requires approximately 5 minutes to cool down before Launch Control can be used again.

After using Launch Control

To assist driving stability, reactivate Dynamic Stability Control, DSC.

System limits

An experienced driver may be able to achieve better acceleration values in DSC OFF mode.

Displays

Vehicle equipment

This chapter describes all standard, country-specific and optional equipment available for the model series. It may therefore describe equipment and functions which are not installed in

your vehicle, for example on account of the optional equipment selected or the national-market version. This also applies to safety-relevant functions and systems. Please comply with the relevant laws and regulations when using the corresponding functions and systems.

Overview, instrument cluster

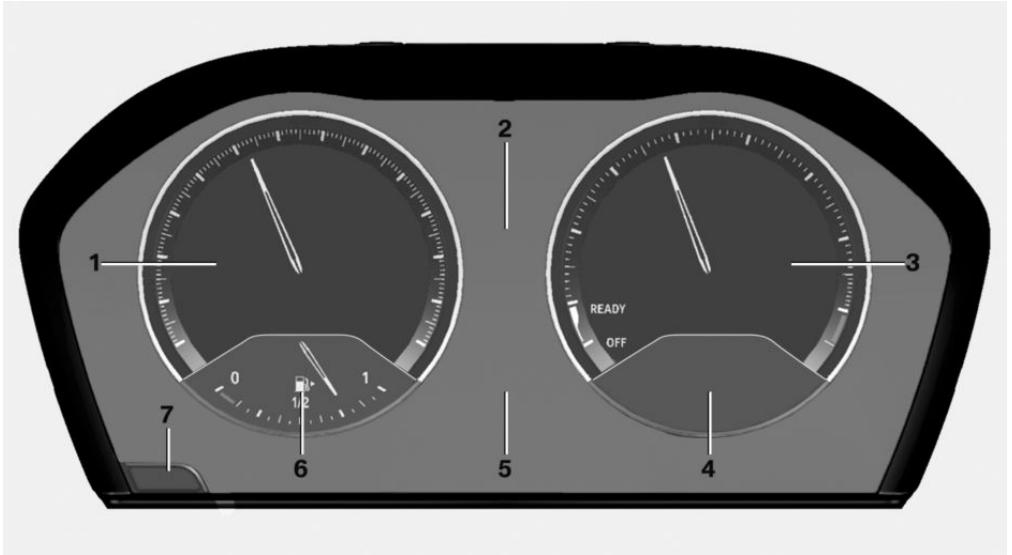

- 1 Speedometer
- 2 Messages, for example, Check Control
- 3 Revolution counter [132](#)
- 4 Current consumption
- 5 Electronic displays
- 6 Fuel gauge [132](#)
- 7 To reset the trip distance recorder [133](#)

Check Control

Principle

Check Control monitors vehicle functions and alerts you to any faults in the monitored systems.

General

A Check Control message is displayed as a combination of indicator or warning lamps and text messages in the instrument cluster and the Head-Up Display.

If required, an acoustic signal is also output and a text message shown on the control display.

Indicator and warning lamps

General

Indicator and warning lamps in the instrument cluster can illuminate in a variety of combinations and colours.

When the engine starts or the ignition is switched on, the functionality of some lights is checked and they illuminate briefly.

Red lights

Seat belt reminder



The driver's side seat belt is not fastened. On some national-market versions: the front passenger seat belt is not fastened or objects are detected on the front passenger seat.

If the indicator lamp flashes or is illuminated: seat belt on the driver's or front passenger side is not fastened. The seat belt reminder can also be triggered if there are objects in the front passenger seat.

Check whether the seat belt has been fastened correctly.

Seat belt reminder for rear seats



Seat belt on the corresponding rear seat is not fastened.

Airbag system



Airbag system and belt tensioners may be faulty.

Have the vehicle checked immediately by a Service Partner of the manufacturer or another qualified Service Partner or a specialist workshop.

Parking brake



The parking brake is engaged.

To release the parking brake, see page 113.

Brake system



Brake system malfunctioning. Continue driving at moderate speed.

Have the vehicle checked immediately by a Service Partner of the manufacturer or another qualified Service Partner or a specialist workshop.

Collision warning



Indicator lamp illuminates: an advance warning is given for example if there is an impending risk of collision or the distance from the vehicle ahead is very short.

Increase the distance.

Indicator lamp flashes: acute warning indicating an imminent risk of a collision because the vehicle is approaching another vehicle at a relatively high differential speed.

Intervene by braking and, if necessary, taking evasive action.

Person warning



Symbol in the instrument cluster.

If there is a risk of collision with a detected person, the symbol illuminates and a signal sounds.

Orange lights

Active Cruise Control



The number of transverse bars shows the selected distance to the vehicle in front.

Camera-based Cruise Control with Stop&Go function, ACC, see page 180.

Vehicle recognition, Active Cruise Control



Indicator lamp illuminates: system has detected a vehicle ahead.

Indicator lamp flashes: the requirements for operation of the system are no longer being met.

The system has been deactivated but will continue to brake until the driver actively takes control of the vehicle by depressing the brake or accelerator pedal.

Yellow lights

Anti-lock Brake System ABS



Braking force boost may be faulty. Avoid sudden braking. Bear in mind that stopping distances will be longer.

Have the vehicle checked immediately by a Service Partner of the manufacturer or another qualified Service Partner or a specialist workshop.

Dynamic Stability Control DSC



Indicator lamp flashes: DSC is regulating the acceleration and braking forces. The vehicle is being stabilised. Decrease

speed and adjust driving style to the road conditions.

Indicator lamp illuminates: DSC has failed.

Have the system checked by a Service Partner of the manufacturer or another qualified Service Partner or a specialist workshop.

DSC, see page [175](#).

Dynamic Stability Control DSC deactivated, or Dynamic Traction Control DTC activated



DSC is deactivated or DTC is activated.

DSC, see page [175](#), and DTC, see page [176](#).

Runflat indicator RPA



RPA reports a loss of tyre inflation pressure in a tyre.

Reduce your speed and carefully stop the vehicle. Avoid heavy braking and sudden steering manoeuvres.

Runflat indicator RPA, see page [160](#).

Tyre Pressure Monitor TPM



Indicator lamp illuminates: the Tyre Pressure Monitor is reporting a low tyre inflation pressure or a flat tyre. Note the information in the Check Control message.

Indicator lamp flashes and then illuminates continuously: no flat tyres or loss of tyre inflation pressure can be detected.

- ▶ Fault due to systems or devices with the same radio frequency: the system is automatically reactivated upon leaving the field of interference.
- ▶ TPM could not complete the reset: perform a system reset again.
- ▶ A wheel without TPM wheel electronics is fitted: if necessary, have it checked by a Service Partner of the manufacturer or another qualified Service Partner or a specialist workshop.
- ▶ Malfunction: have the system checked by a Service Partner of the manufacturer or another qualified Service Partner or a specialist workshop.

For Tyre Pressure Monitor TPM, see page [156](#).

Steering system



The steering system may be faulty.

Have the system checked by a Service Partner of the manufacturer or another qualified Service Partner or a specialist workshop.

Engine warning light



Engine malfunction.

Have the vehicle checked by a Service Partner of the manufacturer or another qualified Service Partner or a specialist workshop.

Socket for on-board diagnosis, see page 288.

Lane Departure Warning



System is switched on and warns you under certain conditions if you leave a detected lane without indicating first.

Lane Departure Warning, see page 169.

Rear fog light



Rear fog light is switched on.

Rear fog light, see page 149.

Green lights

Seat belt reminder for rear seats



Seat belt on the corresponding rear seat is fastened.

Turn indicator



The turn indicator is switched on.

If the indicator lamp flashes more rapidly than usual, a turn indicator bulb has failed.

Turn indicators, see page 114.

Side lights, driving lights



The side lights or driving lights are switched on.

Side lights/low-beam headlights, driving lights control, see page 145.

Front fog lights



The front fog lights are switched on.

Front fog lights, see page 149.

High beam assistant



High beam assistant is switched on.

The high-beam headlights are switched on and off automatically according to traffic conditions.

High beam assistant, see page 148.

Cruise Control



The system is switched on. The speed set using the controls on the steering wheel is maintained.

Manual speed limiter



Indicator lamp illuminates: the system is switched on.

Indicator lamp flashes: set speed limit is exceeded. An acoustic signal may sound.

Reduce speed or deactivate the system.

Blue lights

High-beam headlights



The high-beam headlights are switched on.

High-beam headlights, see page 115.

Hiding Check Control messages

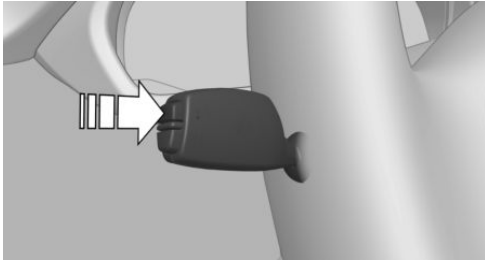

Press the button on the turn indicator lever.

Continuous display

Some Check Control messages are displayed permanently and remain until the fault has been repaired. If a number of malfunctions have occurred at the same time, the messages are displayed in succession.

The messages can be hidden for approximately 8 seconds. Afterwards they are displayed again automatically.

Temporary display

Some Check Control messages are automatically hidden after approximately 20 seconds. The Check Control messages remain saved and can be displayed again.

Displaying saved Check Control messages

Via iDrive:

1. "My Vehicle"
2. "Vehicle status"
3.  "Check Control"
4. Select a text message.

Display

Check Control



At least one Check Control message is displayed or saved.

Text messages

Text messages and symbols in the instrument cluster explain what a Check Control message means and what the indicator and warning lamps signify.

Supplementary text messages

Additional information, for example the cause of the fault and any action required, can be called up via Check Control.

If the message is urgent, the supplementary text is shown in the control display automatically.

Messages displayed at the end of a journey

Certain messages displayed during a journey are displayed again when the ignition is switched off.

Fuel gauge

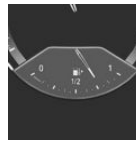

An arrow next to the petrol pump symbol shows on which side of the vehicle the fuel tank filler flap is located.

The angle of the vehicle may cause the display to fluctuate.

Note the information about refuelling.

Revolution counter

It is vital to avoid engine speeds in the red warning zone. In this zone, the fuel supply is interrupted to protect the engine.

Odometer and trip distance recorder

Display



- ▷ Odometer, arrow 1.
- ▷ Trip distance recorder, arrow 2.

Showing/resetting the distance



Press the button.

- ▷ When the ignition is switched off, the time, outside temperature and odometer are displayed.
- ▷ When the ignition is switched on, the trip distance recorder is reset.

Outside temperature

General

If the display drops to +3 °C/+37 °F or lower, a signal sounds.

A Check Control message is shown.

There is an increased risk of black ice.

Safety note

WARNING

Even at temperatures above +3 °C/+37 °F there may be an increased risk of black ice, for example on bridges or on shaded sections of road. There is a risk of accident. At low temperatures, adjust driving style to the weather conditions.

Display



The outside temperature is displayed in the instrument cluster.

Time

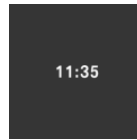

The time is shown in the instrument cluster.

The time can be set on the control display.

Date

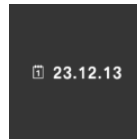

The date is displayed on the instrument cluster.

The date can be set on the control display.

Range

General

If the remaining range is low:

- ▷ A Check Control message is displayed briefly.
- ▷ The on-board computer shows the remaining range.
- ▷ If a sporty driving style is adopted, for example fast cornering, engine function cannot be ensured at all times.

If the range drops below approximately 50 km, 30 miles the Check Control message is displayed continuously.

Safety notes

NOTE

If the range drops below 50 km, 30 miles, the engine may no longer be supplied with sufficient fuel. Engine function is no longer ensured. There is a risk of material damage. Refuel in good time.

Display

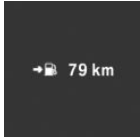

The current range is shown in the instrument cluster.

Current consumption

Instrument cluster



Shows the momentary fuel consumption. It is possible to check the economy and environmental compatibility of your driving style.

Instrument cluster with extended functionality

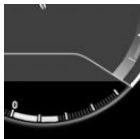

Shows the momentary fuel consumption. It is possible to check the economy and environmental compatibility of your driving style.

Displaying the current consumption

Depending on equipment, the current consumption can be shown as a bar display in the instrument cluster.

Via iDrive:

1. "My Vehicle"
2. "iDrive settings"
3. "Displays"
4. "Instrument cluster"
5. "Analogue additional displays"

Energy recuperation

Display



In overrun mode, the kinetic energy of the vehicle is converted into electrical energy. The vehicle battery is partially charged and fuel consumption can be lowered.

Service requirements

Principle

The function shows the current service requirements and related maintenance jobs.

General

The distance or time remaining until the next service is displayed briefly in the instrument cluster after the ignition is switched on.

The current service requirements can be read out from the vehicle key by a service advisor.

Display

Detailed information on service requirements



More detailed information on the maintenance work required can be displayed on the control display.

Via iDrive:

1. "My Vehicle"
2. "Vehicle status"

3. Tilt the Controller to the left.
4.  "Service requirements"
Maintenance routines and any statutory inspections required are displayed.
5. Select an entry to display more detailed information.

Symbols

Symbols	Description
	No servicing is currently needed.
	Maintenance or a statutory inspection is due soon.
	Service interval has been exceeded.

Entering deadlines

Enter deadlines for statutory vehicle inspections. Ensure that the date and time are set correctly in the vehicle.

Via iDrive:

1. "My Vehicle"
2. "Vehicle status"
3. Tilt the Controller to the left.
4.  "Service requirements"
5. "Vehicle inspection"
6. "Date:"
7. Select the desired setting.

Automatic Service notification

Information on the vehicle's service status and statutory inspections is transmitted to the Service Partner automatically when a service or inspection is due.

It is possible to check when the Service Partner was notified.

Via iDrive:

1. "My Vehicle"
2. "Vehicle status"
3. Tilt the Controller to the left.
4.  "Teleservice Call"

Service history

Principle



Maintenance that has been performed can be displayed on the control display. The function is available as soon as a maintenance visit has been logged in the vehicle data.

General



Have maintenance work performed by a Service Partner of the manufacturer or another qualified Service Partner or a specialist workshop. The maintenance work carried out is entered in the vehicle data.

Displays

Via iDrive:

1. "My Vehicle"
2. "Vehicle status"
3. Tilt the Controller to the left.
4.  "Service requirements"
5.  "Service history"
6. Select an entry to display more detailed information.

Symbols

Symbols	Description
	Green: maintenance has been carried out on time.
	Yellow: maintenance has been carried out later than scheduled.
	Maintenance has not been carried out.

Optimum shift indicator

Principle

The system recommends the most efficient gear for the current driving situation.





General

Depending on the equipment and the national-market version, the optimum shift indicator is active in the manual mode of the Steptronic transmission and with the manual gearbox.



Information on up or down shifting are displayed in the instrument cluster.

For vehicles without optimum shift indicator, the gear engaged is shown.

Manual transmission: displays

Symbol	Description
	Most efficient gear is engaged.
	Shift up into most efficient gear.
	Shift down into most efficient gear.
	Shift to neutral.

Steptronic transmission: displays

Example	Description
	Most efficient gear is engaged.
	Shift to a more efficient gear.

Speed Limit Info with no-overtaking indicator

Speed Limit Info

Principle

Speed Limit Info shows the currently detected speed limit in the instrument cluster.

General

The camera located near the interior mirror detects road signs at the edge of the road as well as variable overhead signs. Road signs with additional instructions, for example restrictions applicable in wet conditions, are also detected, compared with internal vehicle data, for example from the rain sensor, and displayed, depending on the situation.

If a navigation system is installed, the system considers the information saved in the navigation data and also displays the speed limits present on unmarked sections of road.

If a navigation system is not installed, the system has certain technical limitations. Only road signs with speed limits are detected and displayed.

Speed limits when driving into and leaving built-up areas and motorway signs, for example, are not displayed. Speed limits with textual supplementary signs are always shown.

Speed limits for towing a trailer are not shown.

No-overtaking indicator

Principle

Overtaking restriction signs and end of restriction signs which have been detected by the camera are indicated by corresponding symbols in the instrument cluster.

General

The system only considers overtaking restrictions and ends of restrictions that are indicated by means of road signs.

Nothing will be displayed in the following situations:

- ▶ In countries where overtaking restrictions are primarily shown by road markings.
- ▶ On routes without road signs.
- ▶ In the case of railway crossings, lane markings and other situations which indicate an overtaking restriction but which are not signposted to this effect.

Overtaking restrictions for towing a trailer are not shown.

Safety note

WARNING

The system does not relieve you of your personal responsibility to assess the visibility conditions and traffic situation correctly. There is a risk of accident. Adapt your driving style to the traffic conditions. Observe the traffic situation and intervene actively if the situation warrants it.

Overview

Camera

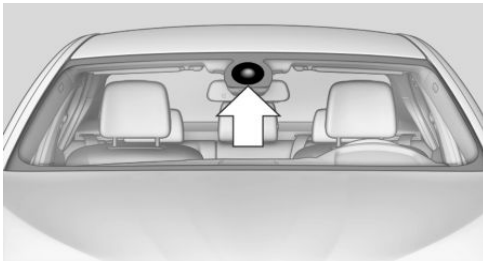

The camera is located near the interior mirror. Keep the windscreen clean and clear in this area.

Display

General

Speed Limit Info is shown continuously in the instrument cluster.

Overtaking restrictions are displayed together with Speed Limit Info.

Speed Limit Info



Last detected speed limit.

If no navigation system is installed, the traffic sign is greyed out after turning off or on longer sections of road.

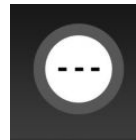

With navigation system:

Speed Limit Info unavailable.

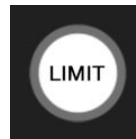

Without navigation system:

No speed limit or end of restriction detected.

Speed Limit Info can also be shown in the Head-Up Display.

No-overtaking indicator



No overtaking.

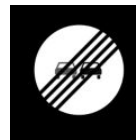

End of overtaking restriction.

Overtaking restrictions can also be shown in the Head-Up Display.

System limits

Functionality may be limited or incorrect information may be displayed in some situations such as:

- ▷ In thick fog and heavy rain or snow.
- ▷ If signs are fully or partially obscured by objects, stickers or paint.
- ▷ If the vehicle is too close to the vehicle ahead.
- ▷ In the case of bright oncoming light or strong reflections.
- ▷ If the area of windscreen in front of the interior mirror is covered with condensation, dirt, stickers, labels, etc.
- ▷ As a result of incorrect detection by the camera.
- ▷ If the speed limits saved in the navigation system are wrong.
- ▷ In areas not covered by the navigation system.
- ▷ If there are navigation discrepancies, for example due to changes in road layout.
- ▷ When overtaking buses or trucks with speed stickers.
- ▷ If traffic signs do not correspond to the standard.
- ▷ During the camera calibration process immediately after vehicle delivery.
- ▷ If signs are detected that apply to a parallel road.

Selection lists

General

Depending on the equipment, the following can be operated via the buttons and the knurled wheel on the steering wheel and shown on the instrument cluster displays and the Head-Up Display:

- ▷ Current audio source.
- ▷ Telephone redial.

- ▷ Activation of the voice control system.

Activating the list and selecting a setting

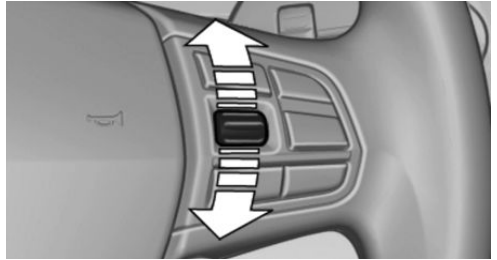

Turn the knurled wheel on the right-hand side of the steering wheel to activate the corresponding list.

1. Turn the knurled wheel and select the required setting.
2. Press the knurled wheel.

Display

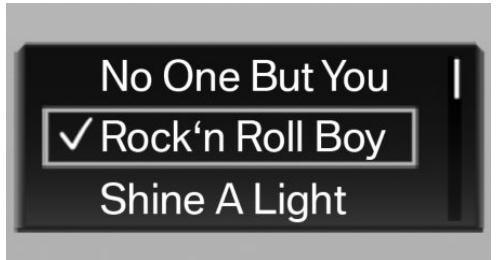

Depending on the equipment, the list in the instrument cluster may differ from the illustration.

On-board computer

Principle

The on-board computer shows various vehicle-related data, for example average values, in the instrument cluster.

Calling up information on the information display

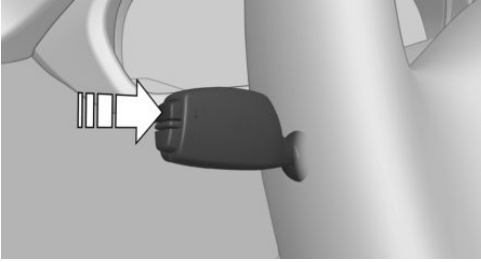

Press the button on the turn indicator lever.

Information is displayed on the information display in the instrument cluster. Press the button repeatedly to display further information.

Overview of information shown

Repeated pressing of the button on the turn indicator lever shows the following information on the information display:

- ▷ Range.
- ▷ Average consumption, fuel.
- ▷ Average consumption since leaving the factory.
- ▷ Current consumption, fuel.
- ▷ Average speed.
- ▷ Date.
- ▷ Engine temperature display.
- ▷ Speed.
- ▷ Depending on the equipment version, arrival time.

When route guidance is activated in the navigation system.

- ▷ Depending on the equipment version, distance to destination.

When route guidance is activated in the navigation system.

- ▷ ECO PRO bonus range.

Selecting information

It is possible to select which information from the on-board computer can be called up on the information display in the instrument cluster.

Via iDrive:

1. "My Vehicle"
2. "iDrive settings"
3. "Displays"
4. "Instrument cluster"
5. Select the desired setting.

Display in the information display

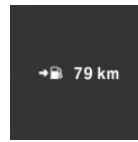

The information from the on-board computer is displayed on the instrument cluster's information display.

Information in detail

Range

Displays the estimated range available with the remaining fuel.

The range is calculated based on your driving style over the last 30 km, 20 miles.

Average consumption

The average consumption is calculated for the period during which the engine is running.

The average consumption is calculated on the route travelled since the last reset of the on-board computer.

Average speed

The calculation of average speed ignores any stationary periods where the engine was switched off manually.

Resetting average values

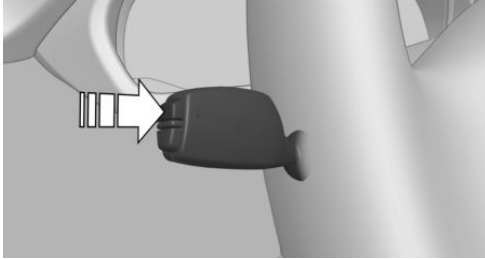

Press and hold the button on the turn indicator lever.

The average consumption since leaving the factory cannot be reset.

Engine temperature display

Principle

Depending on the equipment, the current engine temperature is displayed, based on a combination of the coolant temperature and engine oil temperature. If the engine is at its optimum operating temperature, the display is in the centre position.

General

If the engine oil or coolant and therefore the engine become too hot, a Check Control message is displayed as well.

To check the coolant level, see page [285](#).

Display



Distance to destination

Depending on the equipment, the remaining distance to the destination is displayed if a destination was entered in the navigation system before starting the journey.

The distance to the destination is transferred automatically.

Arrival time

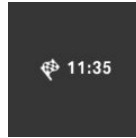

Depending on the equipment, the estimated time of arrival is displayed if a destination was entered in the navigation system before starting the journey.

This requires the time to be set correctly.

On-board computer on the control display

Principle

The on-board computer shows various vehicle-related data, for example average values, on the control display.

General

Two types of on-board computer are available on the control display:

- ▶ "On-board computer": average values, for example consumption, are displayed. The values can be reset individually.
- ▶ "Trip computer": values provide an overview of a particular route, and can be reset as often as required.

Calling up the on-board computer or trip computer

Via iDrive:

1. "My Vehicle"
2. "Driving information"
3. "On-board computer" or "Trip computer"



Resetting the on-board computer

Via iDrive:

1. "My Vehicle"
2. "Driving information"
3. "On-board computer"
4. "Consumption" or "Speed"
5. "OK"

Resetting the trip computer

Via iDrive:

1. "My Vehicle"
2. "Driving information"
3. "Trip computer"
4. If necessary, tilt the Controller to the left.
 - ▷  "Reset": all values are reset.
 - ▷  "Reset automatically": all values are reset if the vehicle is at a standstill for approximately 4 hours.
5. If necessary, "OK"

Sport displays

Principle

On the control display, sports instruments can be shown and the vehicle status can be checked before using the SPORT program.

Sports instruments

General

Values for performance and torque are shown on the control display.

Displaying sports instruments

Via iDrive:

1. "My Vehicle"
2. "Technology in action"
3.  "Sports instruments"

Via the Driving Experience Control:

1. Activate SPORT.
2. "Sport displays"

Vehicle status

General

Following vehicle and ambient data is evaluated:

- ▷ Engine temperature.
- ▷ Outside temperature.
- ▷ Tyre temperature and tyre inflation pressure.

Tyre temperature and tyre inflation pressure are measured while driving.

Checking vehicle status

Via iDrive:

1. "My Vehicle"
2. "Technology in action"
3.  "Vehicle and surroundings"

Via the Driving Experience Control:

1. Activate SPORT.
2. "Sport displays"

Speed warning

Principle

The system can be used to set a speed limit which triggers a warning when it is exceeded.

General

The warning is repeated if the vehicle speed exceeds the set speed limit again, after it has dropped below 5 km/h/3 mph.

Adjusting

Via iDrive:

1. "My Vehicle"
2. "Vehicle settings"

3. "Speed warning"
4. "Warning at:"
5. Turn the Controller until the desired speed is displayed.
6. Press the Controller.

Activating/deactivating

Via iDrive:

1. "My Vehicle"
2. "Vehicle settings"
3. "Speed warning"
4. "Speed warning"

Setting the current speed as the speed warning

Via iDrive:

1. "My Vehicle"
2. "Vehicle settings"
3. "Speed warning"
4. "Select current speed"

Head-Up Display

Principle

The system projects important information, for example the speed, into the driver's field of vision.

The driver is able to absorb this information quickly and concentrate on the traffic conditions.

General

Follow the instructions for cleaning the Head-Up Display. For further information, see chapter "Care".

Safety notes

WARNING

Parts of the body can be trapped on extending and retracting the projection screen of the Head-Up Display. There is a danger of injury. When extending and retracting, make sure that the area of movement of the projection screen is kept clear.

NOTE

The Head-Up Display consists of sensitive components which can be easily scratched or damaged. There is a risk of material damage. Do not place objects onto the Head-Up Display, attach them to system components or insert them into the system. Do not move moving parts manually.

Overview



Switching on/off

When switching on, the projection screen on the Head-Up Display is extended. When switching off, the projection screen on the Head-Up Display is retracted again.

Via iDrive:

1. "My Vehicle"
2. "iDrive settings"
3. "Displays"

4. "Head-up display"
5. "Head-up display"

Display

Overview

The following information is displayed in the Head-Up Display:

- ▷ Speed.
- ▷ Navigation instructions.
- ▷ Check Control messages.
- ▷ Selection list from the instrument cluster.
- ▷ Driver assistance systems.

Some of this information is only shown briefly when needed.

Selecting displays in the Head-Up Display

Via iDrive:

1. "My Vehicle"
2. "iDrive settings"
3. "Displays"
4. "Head-up display"
5. "Information displayed"
6. Select the desired setting.

The setting is saved for the current profile.

Adjusting the brightness

The brightness adapts automatically to the ambient light.

The default setting can be adjusted manually.

Via iDrive:

1. "My Vehicle"
2. "iDrive settings"
3. "Displays"
4. "Head-up display"
5. "Brightness"

6. Turn the Controller until the desired brightness is obtained.
7. Press the Controller.

The brightness of the Head-Up Display can also be adjusted via the instrument lighting if the low-beam headlights are switched on.

The setting is saved for the current profile.

Adjusting the height

Via iDrive:

1. "My Vehicle"
2. "iDrive settings"
3. "Displays"
4. "Head-up display"
5. "Height"
6. Turn the Controller until the desired height is obtained.
7. Press the Controller.

The setting is saved for the current profile.

The height of the Head-Up Display can also be saved with the memory function, see page [93](#).

Adjusting the rotation

The image of the Head-Up Display can be rotated about its axis.

Via iDrive:

1. "My Vehicle"
2. "iDrive settings"
3. "Displays"
4. "Head-up display"
5. "Rotation"
6. Turn the Controller until the desired setting is reached.
7. Press the Controller.

The setting is saved for the current profile.

Visibility of the display

The visibility of the information shown on the Head-Up Display can be affected by the following:

- ▷ Seat position.
- ▷ Objects placed on the Head-Up Display cover.
- ▷ Sunglasses with certain polarisation filters.
- ▷ Wet roads.
- ▷ Adverse lighting conditions.

If the image is distorted, have the default settings checked by a Service Partner of the manufacturer or another qualified Service Partner or a specialist workshop.

Follow the instructions for cleaning the Head-Up Display, see page [312](#).

Vehicle status

General



The status of some systems can be displayed and actions performed on them.



Calling up the vehicle status

Via iDrive:

1. "My Vehicle"
2. "Vehicle status"

Overview of information shown

Symbols	Description
	"Flat Tyre Monitor": status of the runflat indicator RPA, see page 160 .
	"Tyre Pressure Monitor": status of the Tyre Pressure Monitor TPM, see page 156 .
	"Engine oil level": electronic oil level check, see page 281 .

Symbols	Description
	"Check Control": to display saved Check Control messages, see page 132 .
	"Service requirements": to display service requirements, see page 134 .
	"Teleservice Call": Teleservice Call.

Lights

Vehicle equipment

This chapter describes all standard, country-specific and optional equipment available for the model series. It may therefore describe equipment and functions which are not installed in your vehicle, for example on account of the optional equipment selected or the national-market version. This also applies to safety-relevant functions and systems. Please comply with the relevant laws and regulations when using the corresponding functions and systems.

Overview

Switches in the vehicle



The light switch panel is located next to the steering wheel.

Symbol	Function
	Front fog lights.
	Rear fog light.
	Automatic driving lights control. Adaptive light functions.

Symbol	Function
	Lights off. Daytime running lights.
	Side lights.
	Low-beam headlights.
	Manual headlight beam throw adjustment.
	Instrument lighting.

Side lights, low-beam headlights and parking light

General

Switch position: 0 ,  , 

If the driver's door is opened when the ignition is switched off, the exterior lights are switched off automatically.

Side lights

Switch position: 

The vehicle is illuminated all round.

Do not leave the side lights on for extended periods of time, as this could drain the battery and you might not have enough power to start the engine.

To park, switch on the one-sided parking light, see page 146.

Low-beam headlights

Switch position: 

The low-beam headlights illuminate when the ignition is switched on.

Parking light

Principle

The vehicle can be illuminated on one side.

Switching on

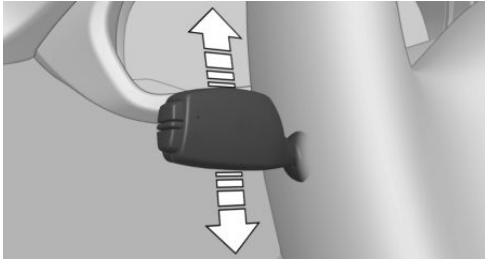

With radio-ready state switched off, push the lever up or down beyond the resistance point for approximately 2 seconds.

Switching off

Press the lever briefly in the opposite direction as far as the resistance point.

Welcome lights and home lights

Welcome lights

General

Depending on the equipment and the ambient brightness, individual light functions may be switched on briefly when the vehicle is unlocked.

Activating/deactivating

Switch position:  , 

Via iDrive:

1. "My Vehicle"
2. "Vehicle settings"
3. "Lights"
4. "Exterior lighting"
5. "Welcome lights"

The setting is saved for the current driver profile.

Home lights

General

If the headlight flasher is activated after switching off the radio-ready state, the low-beam headlights remain on for a time.

Setting the duration

Via iDrive:

1. "My Vehicle"
2. "Vehicle settings"
3. "Lights"
4. "Exterior lighting"
5. "Home lights"
6. Set the duration.

The setting is saved for the current driver profile.

Automatic driving lights control

Principle

Depending on ambient light conditions, the system switches the low-beam headlights on or off automatically, for example in a tunnel, at twilight and in rain or snow.

General

The headlights may also come on when the sun is low against a blue sky.

The low-beam headlights always remain on when the fog lights are switched on.

Activating

Switch position: 

The indicator lamp in the instrument cluster is illuminated when the low-beam headlights are switched on.

System limits

The automatic driving lights control is no substitute for using your own judgement to assess the light conditions.

The sensors are unable to recognise fog or hazy weather, for example. In such situations, switch on the lights manually.

Daytime running lights

General

Switch position: 0, 

The daytime running lights illuminate when the ignition is switched on.

Activating/deactivating

In some countries daytime running lights are compulsory, in which case the daytime running lights cannot be deactivated.

Via iDrive:

1. "My Vehicle"
2. "Vehicle settings"
3. "Lights"
4. "Exterior lighting"
5. Select the desired setting.

The setting is saved for the current profile.

Adaptive light functions

Principle

Adaptive light functions makes it possible to illuminate the road responsively.

General

The adaptive light functions consist of one system or multiple systems, depending on the equipment version:

- ▷ Adaptive Headlights, see page 147.
- ▷ Variable light distribution, see page 147.
- ▷ Cornering light, see page 148.

Activating

Switch position: 

The adaptive light functions are active when the engine is running.

Adaptive Headlights

The headlight beams follow the road ahead in response to the steering angle and other parameters.

To prevent dazzling oncoming vehicles, the Adaptive Headlights do not swivel to the opposite side of the road when the vehicle is at standstill.

Variable light distribution

Principle

Variable light distribution illuminates the road even more effectively.

General

The light distribution is automatically adapted to the speed.

City light

The light beam from the low-beam headlights is extended at the sides.

Motorway beam pattern

The range of the low-beam headlights is increased.

Cornering light

When turning off or on tight bends, for example hairpin bends, up to a certain speed, a cornering light is added that better illuminates the inside area of the bend.

The cornering light is switched on automatically depending on the steering angle or, where applicable, activation of the turn indicators.

When reversing, the cornering light is activated automatically as appropriate, irrespective of the steering angle.

Manual headlight beam throw adjustment

General

Depending on the equipment, adjust the beam throw of the low-beam headlights manually in accordance with the vehicle load. Otherwise, the glare will disturb drivers of oncoming vehicles.

Settings

Values after / are applicable when towing a trailer.

- ▷ 0/1 = 1 to 2 persons without luggage.
- ▷ 1/1 = 5 persons without luggage.
- ▷ 1/2 = 5 persons with luggage.
- ▷ 2/2 = 1 person, luggage compartment fully loaded.

Adaptive headlight beam throw adjustment

Adaptive headlight beam throw adjustment compensates for acceleration and braking manoeuvres and vehicle load conditions to prevent oncoming vehicles from being dazzled. Illumination of the road is optimised.

High beam assistant

Principle

High beam assistant detects other road users in good time and activates or deactivates the high beam according to traffic conditions.

General

High beam assistant ensures that the high-beam headlights are switched on when the traffic situation allows. The system does not switch on the high-beam headlights at low speeds.

The system responds to the lights from oncoming traffic and traffic driving ahead of you, and to ambient lighting, for example in built-up areas.

The high-beam headlights can be switched on and off manually at any time.

If Selective Beam is installed, the high-beam headlights are not switched off for oncoming vehicles or vehicles driving ahead of you. Instead, the system masks only those areas of the beam which would otherwise dazzle oncoming traffic or traffic driving ahead. In this case, the blue indicator lamp continues to illuminate.

Activating/deactivating

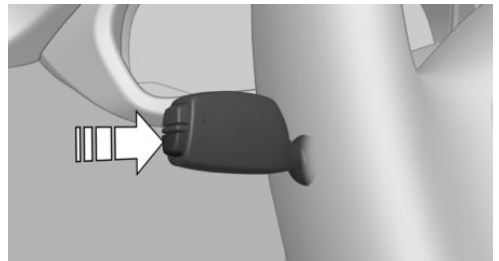

Switch position, depending on the equipment:



Press the button on the turn indicator lever.



The indicator lamp in the instrument cluster is illuminated when the low-beam headlights are switched on.

The system will switch automatically between low-beam and high-beam headlights.



The blue indicator lamp in the instrument cluster illuminates if the high beam is switched on by the system.

High beam assistant is deactivated by switching the high beams on and off manually, see page 115.

To reactivate high beam assistant, press the button on the turn indicator lever.

System limits

High beam assistant cannot replace the driver's own judgement as to when to use the high-beam headlights. Therefore activate the dipped headlights manually if the situation requires it.

In the following situations, the system will not operate or its operation will be impaired and your intervention may be required:

- ▶ In extremely adverse weather conditions such as fog or heavy precipitation.
- ▶ When detecting poorly lit road users such as pedestrians, cyclists, horse riders or carriages and when trains or ships are close to the road, or when animals are crossing the road.
- ▶ On tight bends, on steep brows or hollows of hills, when there is crossing traffic or if the view of oncoming vehicles on a motorway is partly obstructed.
- ▶ In poorly lit towns and where there are highly reflective signs.
- ▶ If the area of windscreen in front of the interior mirror is covered with condensation, dirt, stickers, labels, etc.

Fog lights

Front fog lights

Principle

The front fog lights work alongside the low-beam headlights to illuminate a wider area of the roadway.

Operating requirements

Before the front fog lights are switched on, the side lights or low-beam headlights must be switched on.

Switching on/off



Press the button.

The green indicator lamp illuminates if the fog lights are switched on.

If automatic driving lights control, see page 146, has been activated, the low-beam headlights illuminate automatically when the front fog lights are switched on.

Guiding fog lights

Switch position: 

The light distribution of the low-beam headlights may be adapted to the foggy conditions according to the speed.

Rear fog light

Operating requirements

Before the rear fog light is switched on, the low-beam headlights or the front fog lights must be switched on.

Switching on/off



Press the button.

The yellow indicator lamp illuminates when the rear fog light is switched on.

If automatic driving lights control, see page 146, has been activated, the low-beam headlights switch on automatically when the rear fog light is switched on.

Left-hand/right-hand traffic

General

When driving in countries where vehicles drive on the opposite side of the road to your vehicle's country of registration, you will need to prevent your headlights from dazzling oncoming vehicles.

Halogen headlights

The Service Partner of the manufacturer or another qualified Service Partner or a specialist workshop has light benders available. When affixing the masking foil, follow the instructions provided.

LED headlights

The light distribution of the headlights prevents the dipped-beam headlights from dazzling other road users even when driving in a country where vehicles drive on the other side of the road to your vehicle's country of registration.

Adaptive Headlights

When driving in countries which drive on the other side of the road to your vehicle's country of registration, do not drive with the switch in position . Otherwise, the variable light distribution may dazzle other road users.

Instrument lighting

Operating requirements

The brightness can only be adjusted when the side lights or the low-beam headlights are switched on.

Adjusting



The brightness can be adjusted using the knurled wheel.

Interior light

General

Depending on equipment, the interior light, the footwell lights, door entry lighting and the ground lighting are controlled automatically.

The brightness of some equipment is controlled by the knurled wheel for the instrument lighting.

Overview



- 1 Interior light
- 2 Reading lights

Switching the interior light on/off



Press the button.

To switch off permanently: press and hold the button for approximately 3 seconds.

Switching the reading lights on/off



Press the button.

Depending on the equipment version, there are reading lights located at the front and in the rear beside the interior light.

Ambient lighting

General

Depending on the equipment, the lighting for some of the interior lights can be adjusted.

Selecting the colour scheme

Via iDrive:

1. "My Vehicle"
2. "Vehicle settings"
3. "Lights"
4. "Interior lighting"
5. "Lighting design"
6. Select the desired setting.

To deactivate the ambient lighting: "Off".

Adjusting the brightness

Via iDrive:

1. "My Vehicle"
2. "Vehicle settings"
3. "Lights"
4. "Interior lighting"
5. "Brightness"
6. Adjust the brightness.

Safety

Vehicle equipment

This chapter describes all standard, country-specific and optional equipment available for the model series. It may therefore describe equipment and functions which are not installed in

your vehicle, for example on account of the optional equipment selected or the national-market version. This also applies to safety-relevant functions and systems. Please comply with the relevant laws and regulations when using the corresponding functions and systems.

Airbags

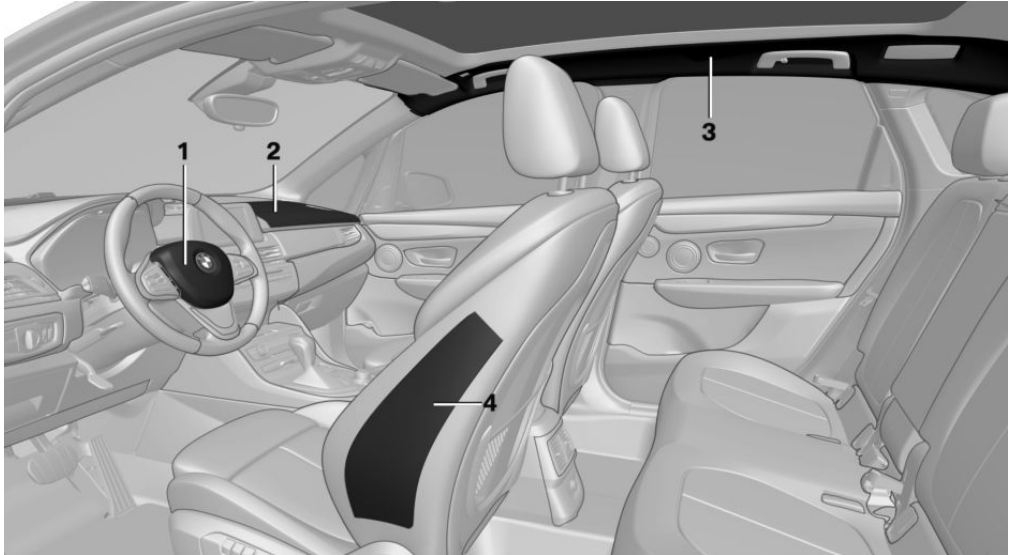

- 1 Front airbag, driver
- 2 Front airbag, front passenger
- 3 Head airbag
- 4 Side airbag

Front airbags

Front airbags protect the driver and front passenger in the event of a head-on collision where the protection of the seat belts alone would no longer be sufficient.

Side airbag

In a side-on crash, the side airbag protects the side of the body in the chest and pelvic area.

Head airbag

The head airbag protects the head in the event of a side-on crash.

Protective function

Airbags are not activated in every collision, for example in minor accidents and rear-end collisions.

Information for optimum airbag effectiveness

WARNING

If the seat position is incorrect or the deployment area of the airbag is restricted, the airbag system cannot provide the intended level of protection or may cause additional injuries when it deploys. There is a risk of injury or even death. Observe the following to achieve optimum protective function.

- ▶ Keep a distance from the airbags.
 - ▶ Always grip the steering wheel at the steering wheel rim. Place your hands in the 3 o'clock and 9 o'clock positions to minimise the risk of injury to hands or arms when the airbag deploys.
 - ▶ Adjust the seat and steering wheel so the driver can reach over the steering wheel diagonally. Select the settings so that, when reaching over, the shoulders stay in contact with the backrest and the upper body stays as far away from the steering wheel as possible.
 - ▶ Make sure that vehicle occupants keep their head away from the side airbag.
 - ▶ Make sure that the front-seat passenger is sitting correctly, i.e. with their feet and legs in the footwell, not resting on the dashboard.
 - ▶ Do not place any other persons, pets or objects between the airbags and occupants.
 - ▶ Keep the dashboard and windscreen area on the passenger side clear, for example do not attach adhesive foil or covers and do not fit brackets for navigation devices or mobile telephones, for example.
 - ▶ Do not glue the airbag covers and do not cover or modify them in any way.
- ▶ Do not use the front airbag cover on the front passenger's side as a tray.
 - ▶ Do not install seat covers, cushions or other objects on the front seats if they are not specifically designed for use on seats with integral side airbags.
 - ▶ Do not hang items of clothing, for example coats or jackets, over the backrests.
 - ▶ Do not modify individual components of the system or its wiring. This also applies to the covers of the steering wheel, the dashboard and seats.
 - ▶ Do not dismantle the airbag system.

Even if all this information is observed, injuries resulting from contact with the airbag cannot be entirely ruled out in every situation.

The noise caused by the deployment of an airbag may lead to temporary hearing loss in vehicle occupants sensitive to noise.

Operational readiness of the airbag system

Safety notes

WARNING

Individual components of the airbag system may be hot after airbag deployment. There is a danger of injury. Do not touch individual components.

WARNING

Work carried out incorrectly can cause the airbag system to fail, malfunction or deploy accidentally. If there is a malfunction, the airbag system might not deploy as intended in an accident, even if the impact is of the appropriate severity. There is a risk of injury or even death. Have the airbag system tested, repaired or removed and disposed of by a Service Partner of

the manufacturer or another qualified Service Partner or a specialist workshop.

Correct function



When the ignition is switched on, the warning lamp in the instrument cluster illuminates briefly to indicate that the entire airbag system and the belt tensioners are operational.

Airbag system malfunction

- ▷ The warning lamp does not illuminate after the ignition is switched on.
- ▷ The warning lamp is permanently illuminated.

Not for Australia/New Zealand: Key switch for front passenger airbags

General

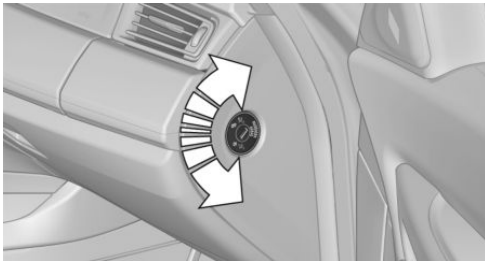

The front and side airbags for the front passenger can be deactivated and reactivated using the integrated key from the vehicle key.

Deactivating the front passenger airbags



1. Insert the key and press inwards where necessary.
2. While the key is pressed inwards, turn it to the OFF position as far as it will go. Once the stop position has been reached, remove the key.
3. Make sure that the key switch is in the end position so that the airbags are deactivated.

The front passenger airbags are deactivated.
The driver's airbags remain active.

If a child restraint system is no longer installed on the front passenger seat, reactivate the front passenger airbags so that they can deploy as intended in the event of an accident.

The status of the airbags is shown by the front passenger airbag indicator lamp, see page 155.

Activating the front passenger airbags



1. Insert the key and press inwards where necessary.
2. While the key is pressed inwards, turn it to the ON position as far as it will go. Once the stop position has been reached, remove the key.
3. Make sure that the key switch is in the end position so that the airbags are activated.

The front passenger airbags are reactivated and can deploy correctly if the need arises.

Indicator lamp for front passenger airbags

Display



Depending on the equipment, there will be one of the illustrated indicator lamps.



The indicator lamp for the front passenger airbags shows the operating status of the front passenger airbags.

After switching on the ignition, the light illuminates briefly and then shows whether the airbags are activated or deactivated.

Depending on the equipment version, different indicator lamps may illuminate.

Display

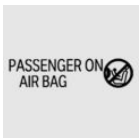

If the front passenger airbag is activated, the indicator lamp illuminates for a short period and then extinguishes.



When the front passenger airbags are deactivated, the indicator lamp remains illuminated.



When the front passenger airbags are activated, the indicator lamp is not illuminated.

Active pedestrian protection

Principle

The active pedestrian protection system raises the bonnet if the vehicle's front end collides with a pedestrian. Sensors underneath the bumper are used for detection. This provides additional deformation space underneath the bonnet for the subsequent head impact.

Safety notes

WARNING

The system may trigger inadvertently if contact is made with individual components of the hinges and bonnet locks. There is a risk of injury or material damage. Do not touch individual components of the hinges and bonnet locks.

WARNING

Modifications to the pedestrian protection system can lead to a failure, a malfunction or accidental triggering of the pedestrian protection system. There is a risk of injury or even death. Do not modify the pedestrian protection system, its individual components or its wiring. Do not dismantle the system.

WARNING

Work carried out incorrectly can lead to a failure, malfunction or accidental triggering of the system. If there is a malfunction, the system might not trigger as intended in an accident, even if the impact is of the appropriate severity. There is a risk of injury or even death. Have the system tested, repaired or removed and disposed of by a Service Partner of the manufacturer or another qualified Service Partner or a specialist workshop.

⚠ WARNING

If the system has been deployed or is damaged, its functionality will be limited or it may no longer work at all. There is a risk of injury or even death.

If the system has been triggered or is damaged, have it checked and renewed at a Service Partner of the manufacturer or another qualified Service Partner or a specialist workshop.

⚠ NOTE

Opening the bonnet when the pedestrian protection system has triggered may damage the bonnet or the pedestrian protection system. There is a risk of material damage. Do not open the bonnet after the Check Control message is displayed. Have checks performed by a Service Partner of the manufacturer or another qualified Service Partner or a specialist workshop.

System limits

The active pedestrian protection system is only triggered at speeds between approximately 30 km/h, 18 mph and 55 km/h, 34 mph.

For safety reasons, the system may also trigger in rare instances where impact with a pedestrian cannot be excluded beyond all doubt, for example:

- ▷ Collision with a skip or a boundary post.
- ▷ Collision with animals.
- ▷ Stone impact.
- ▷ Driving into a snow drift.

Malfunction

A Check Control message is shown. The system has been triggered or is faulty.

Have the system checked immediately by a Service Partner of the manufacturer or another

qualified Service Partner or a specialist workshop.

**Tyre Pressure Monitor
TPM****Principle**

The system monitors the tyre inflation pressure in the four tyres installed on the vehicle. The system warns if the tyre inflation pressure in one or more tyres has fallen considerably.

General

Sensors in the tyre valves measure the tyre inflation pressure and, depending on the model, the tyre temperature.

When operating the system, please also comply with the additional information and notes under Tyre inflation pressure, see page 262.

Operating requirements

The following requirements must be met for the system, otherwise reliable signalling of a loss of tyre inflation pressure is not ensured:

- ▷ After every tyre or wheel change, the system must be reset once the tyre inflation pressures are correct.
- ▷ A reset must be carried out after the tyre inflation pressure has been adjusted to a new value.
- ▷ Wheels with TPM wheel electronics.

Status display**Current status**

The status of the system, for example whether the system is active, can be shown on the control display.

Via iDrive:

1. "My Vehicle"

2. "Vehicle status"
3.  "Tyre Pressure Monitor"

The current status is displayed.

Tyre statuses

General

The status of the system and tyres is indicated by the wheel colour and a message on the control display.

All wheels green

System is active and is using the tyre inflation pressures saved during the last reset for the warning.

One to four wheels yellow

There is a flat tyre or major loss of tyre inflation pressure in the tyres shown.

Wheels grey

Tyre pressure losses may not be detected.

Possible causes:

- ▶ Malfunction.
- ▶ System reset is being performed.

Additional information

The current tyre inflation pressures and, depending on the model, tyre temperatures are also displayed in the condition indicator. The values shown are current values and may change due to the effects of driving conditions or weather conditions.

Performing a reset

Via iDrive:

1. "My Vehicle"
2. "Vehicle status"
3.  RESET "Tyre Pressure Monitor"
4. Start the engine but do not drive off.

5. Reset the tyre inflation pressure: "Perform reset".

6. Drive off.

The wheels are shown grey and the following appears on the display: "Resetting Tyre Pressure Monitor...".

After driving for several minutes, the set tyre inflation pressures are accepted as reference values. The reset is completed automatically during the journey.

If the reset was successful, the wheels are shown in green on the control display and "Tyre Pressure Monitor active. See label for recommended pressures." appears.

You can interrupt your journey at any time. The reset resumes automatically when you continue your journey.

Messages

General

Dynamic Stability Control DSC will be activated if necessary as soon as a message for low tyre inflation pressure appears.

Safety note

WARNING

A damaged standard tyre with too little or no tyre inflation pressure impairs driving characteristics, for example steering and braking. Tyres with run-flat properties allow a limited level of stability to be maintained. There is a risk of accident. Do not continue driving if the vehicle is fitted with standard tyres. Comply with the notes on run-flat tyres and continuing a journey with these tyres.

If a tyre inflation pressure check is required

Message

A symbol with a Check Control message is shown on the control display.

Symbol Possible cause



The system has detected a wheel change, but no reset has been performed.

No reset has been performed on the system. System warnings are based on the tyre inflation pressures saved during the last reset.

The tyre was not inflated properly.



The tyre inflation pressure has dropped compared to the last reset.

Action

1. Check the tyre inflation pressure and adjust as necessary.
2. Perform a reset of the system.

If the tyre inflation pressure is too low

Message



A yellow warning lamp is illuminated in the instrument cluster.

In addition, a symbol with a Check Control message is shown on the control display.

Symbol Possible cause



There has been a loss of tyre inflation pressure.

No reset has been performed on the system. System warnings are based on the tyre inflation pressures saved during the last reset.

Action

1. Reduce speed and continue driving at moderate speed. Do not exceed a speed of 130 km/h, 80 mph.
2. At the next opportunity, for example at a filling station, check the tyre inflation pressure in all four tyres and correct if necessary.
3. Perform a reset of the system.

If there is a significant loss of tyre inflation pressure

Message



A yellow warning lamp is illuminated in the instrument cluster.

In addition, a symbol indicating the affected tyre is shown in a Check Control message on the control display.

Symbol Possible cause



There is a flat tyre or substantial loss of tyre inflation pressure.

No reset has been performed on the system. System warnings are based on the tyre inflation pressures saved during the last reset.

Action

1. Reduce your speed and carefully stop the vehicle. Avoid heavy braking and sudden steering manoeuvres.
2. Check whether the vehicle is equipped with standard tyres or run-flat tyres.

The symbol identifying run-flat tyres, see page 266, is a circle with the letters RSC on the tyre side wall.

What to do in the event of a flat tyre

Standard tyres

1. Identify the damaged tyre.

To do this, check the air pressure in all four tyres, for example using the tyre inflation pressure indicator of a flat tyre kit.

If all four tyres are inflated to the correct tyre inflation pressures, the Tyre Pressure Monitor might not have been reset. Perform a reset.

If it is not possible to identify tyre damage, contact a Service Partner of the manufacturer or another qualified Service Partner or a specialist workshop.

2. Repair the flat tyre, for example using a flat tyre kit or by changing the wheel.

The use of sealant, for example a flat tyre kit, can damage the TPM wheel electronics. In this case, have the electronics replaced at the next opportunity.

Run-flat tyres

Safety notes

WARNING

A run-flat tyre with too little or no tyre inflation pressure will change the vehicle's handling characteristics, for example there may be reduced directional stability when braking, longer braking distances and different self-steering characteristics. There is a risk of accident. Drive with care and do not exceed a speed of 80 km/h, 50 mph.

WARNING

Continuing to drive with a flat tyre can result in heavy trailers starting to slalom. There is a risk of accident or material damage. When driving with a trailer and a flat tyre, do not exceed the speed of 60 km/h, 35 mph. If the trailer starts to snake, brake immediately and make the necessary steering corrections as carefully as possible.

Maximum speed

If a tyre is damaged you can continue your journey, but do not exceed a maximum speed of 80 km/h, 50 mph.

Continuing a journey with a flat tyre

If you continue a journey with a flat tyre:

1. Avoid heavy braking and sudden steering manoeuvres.
2. Do not exceed a speed of 80 km/h, 50 mph.
3. At the next opportunity, check the tyre pressure in all four tyres.

If all four tyres are inflated to the correct tyre inflation pressures, the Tyre Pressure Monitor might not have been reset. Perform a reset.

Possible driving distance with a deflated tyre

The possible driving distance varies depending on the load and stresses the vehicle is subjected to, for example speed, the nature of the road surface, outside temperature. The driving distance may be shorter but can be increased if a careful driving style is adopted.

If the vehicle is moderately loaded and subjected to low stress, it is possible to travel up to 80 km, 50 miles.

Driving properties with damaged tyres

Driving with damaged tyres changes the vehicle's handling characteristics and may lead to the following situations, for example:

- ▷ The vehicle losing traction more quickly.
- ▷ Longer stopping distances.
- ▷ Different self-steering characteristics.

Adapt your driving style. Avoid abrupt steering or driving over obstacles, for example kerbs or pot-holes.

Final tyre failure

Vibration or loud noises during the journey may be an indication that the tyre has finally failed.

Reduce your speed and stop the vehicle. Parts of the tyre could detach, which might lead to an accident.

Do not continue driving, but instead contact a Service Partner of the manufacturer or another qualified Service Partner or a specialist workshop.

System limits

Temperature

The tyre inflation pressure depends on the temperature of the tyre.

The pressure increases as the temperature of the tyre increases, for example while driving or when exposed to sunlight.

The pressure decreases when the tyre temperature drops.

Due to the system's inherent warning thresholds, therefore, this behaviour may cause a warning to be triggered when significant temperature drops occur.

Sudden loss of tyre inflation pressure

No warning can be given in the event of extreme, sudden tyre failure caused by external factors.

Reset not carried out

The system will not function correctly if a reset has not been carried out, for example, a flat tyre may be reported even though the tyre pressure is correct.

Malfunction



The yellow warning lamp flashes and then illuminates continuously. A Check Control message is shown. Tyre pressure losses may not be detected.

In these cases:

- ▶ A wheel without TPM wheel electronics is fitted: have the wheels checked if necessary.

- ▶ A wheel without TPM wheel electronics is fitted, for example spare wheel: have the wheels checked if necessary.
- ▶ Malfunction: have the system checked.
- ▶ The system was unable to complete the reset. Perform a system reset again.
- ▶ Fault due to systems or devices with the same radio frequency: the system is automatically reactivated upon leaving the field of interference.

Runflat indicator RPA

Principle

The system identifies a loss of tyre inflation pressure by comparing the rotational speeds of the individual wheels during the journey.

A loss of tyre inflation pressure changes the diameter, and with it the rotational speed, of the corresponding wheel. The discrepancy is detected and reported as a flat tyre.

The system does not measure the tyre inflation pressure as such.

Operating requirements

The following requirements must be met for the system, otherwise reliable signalling of a loss of tyre inflation pressure is not ensured:

- ▶ After every tyre or wheel change, the system must be initialised once the tyre inflation pressures are correct.
- ▶ The system must be initialised after the tyre inflation pressure is adjusted to a new value.

Status display

It is possible to display the current status of the runflat indicator, for example to check whether the RPA is active.

Via iDrive:

1. "My Vehicle"
2. "Vehicle status"

3. "Flat Tyre Monitor"

The status is displayed.

Initialisation required

An initialisation must be performed in the following situations:

- After adjusting the tyre inflation pressure.
- After changing a tyre or wheel.

Initialising

Initialisation saves the set tyre inflation pressures as reference values for subsequent detection of a flat tyre. Initialisation is started by confirming the correct tyre inflation pressures.

Do not initialise the system if driving with snow chains fitted.

Via iDrive:

1. "My Vehicle"
2. "Vehicle status"
3.  "Flat Tyre Monitor"
4. Start the engine but do not drive off.
5. Start the initialisation: "Perform reset"
6. Drive off.

Initialisation is completed during the journey; this process can be interrupted at any time.

Initialising resumes automatically when you continue your journey.

Messages

General

Dynamic Stability Control DSC is activated if necessary as soon as the message for a flat tyre appears.

Safety note

WARNING

A damaged standard tyre with too little or no tyre inflation pressure impairs driving characteristics, for example steering and braking. Tyres with run-flat properties allow a limited level of stability to be maintained. There is a risk of accident. Do not continue driving if the vehicle is fitted with standard tyres. Comply with the notes on run-flat tyres and continuing a journey with these tyres.

Flat tyre message



A yellow warning lamp is illuminated in the instrument cluster.

In addition, a symbol with a Check Control message is shown on the control display.

Symbol Possible cause



There is a flat tyre or substantial loss of tyre inflation pressure.

Action

1. Reduce your speed and carefully stop the vehicle. Avoid heavy braking and sudden steering manoeuvres.
2. Check whether the vehicle is equipped with standard tyres or run-flat tyres.

The symbol identifying run-flat tyres, see page 266, is a circle with the letters RSC on the tyre side wall.

What to do in the event of a flat tyre

Standard tyres

1. Identify the damaged tyre.

To do this, check the air pressure in all four tyres, for example using the tyre inflation pressure indicator of a flat tyre kit.

If all four tyres are inflated to the correct tyre inflation pressures, the runflat indicator might not have been initialised. In this case initialise the system.

If it is not possible to identify tyre damage, contact a Service Partner of the manufacturer or another qualified Service Partner or a specialist workshop.

2. Repair the flat tyre, for example using a flat tyre kit or by changing the wheel.

Run-flat tyres

Safety notes

WARNING

A run-flat tyre with too little or no tyre inflation pressure will change the vehicle's handling characteristics, for example there may be reduced directional stability when braking, longer braking distances and different self-steering characteristics. There is a risk of accident. Drive with care and do not exceed a speed of 80 km/h, 50 mph.

WARNING

Continuing to drive with a flat tyre can result in heavy trailers starting to slalom. There is a risk of accident or material damage. When driving with a trailer and a flat tyre, do not exceed the speed of 60 km/h, 35 mph. If the trailer starts to snake, brake immediately and make the necessary steering corrections as carefully as possible.

Maximum speed

If a tyre is damaged you can continue your journey, but do not exceed a maximum speed of 80 km/h, 50 mph.

Continuing a journey with a flat tyre

If you continue a journey with a flat tyre:

1. Avoid heavy braking and sudden steering manoeuvres.
2. Do not exceed a speed of 80 km/h, 50 mph.
3. At the next opportunity, check the tyre pressure in all four tyres.

If all four tyres are inflated to the correct tyre inflation pressures, the runflat indicator might not have been initialised. In this case initialise the system.

Possible driving distance with a deflated tyre

The possible driving distance varies depending on the load and stresses the vehicle is subjected to, for example speed, the nature of the road surface, outside temperature. The driving distance may be shorter but can be increased if a careful driving style is adopted.

If the vehicle is moderately loaded and subjected to low stress, it is possible to travel up to 80 km, 50 miles.

Driving properties with damaged tyres

Driving with damaged tyres changes the vehicle's handling characteristics and may lead to the following situations, for example:

- ▶ The vehicle losing traction more quickly.
- ▶ Longer stopping distances.
- ▶ Different self-steering characteristics.

Adapt your driving style. Avoid abrupt steering or driving over obstacles, for example kerbs or pot-holes.

Final tyre failure

Vibration or loud noises during the journey may be an indication that the tyre has finally failed.

Reduce your speed and stop the vehicle. Parts of the tyre could detach, which might lead to an accident.

Do not continue driving, but instead contact a Service Partner of the manufacturer or another qualified Service Partner or a specialist workshop.

System limits

In the following situations, the system could be slow to respond or could work incorrectly:

- ▷ A natural, even loss of tyre inflation pressure in all four tyres that occurs over time will not be detected. Therefore check the tyre inflation pressure at regular intervals.
- ▷ No warning can be given in the event of sudden tyre failure caused by external factors.
- ▷ If the system has not been initialised.
- ▷ When driving on snow-covered or slippery surfaces.
- ▷ Dynamic driving style: drive wheels slipping, high lateral acceleration.
- ▷ When driving with snow chains.

Intelligent Safety

Principle

Intelligent Safety enables the driver assistance systems to be operated centrally. Depending on the equipment, Intelligent Safety consists of one or more systems which can help to avoid the risk of a collision.

- ▷ Collision warning with light city braking function, see page 164.
- ▷ Person warning, see page 167.
- ▷ Lane Departure Warning, see page 169.

Safety notes

WARNING

The system does not relieve you of your personal responsibility to assess the visibility conditions and traffic situation correctly. There is a risk of accident. Adapt your driving style to the traffic conditions. Observe the traffic situation and intervene actively if the situation warrants it.

WARNING

Displays and warnings do not relieve you of your personal responsibility. System limitations can mean that warnings or system responses are not issued or are issued too late, incorrectly or without justification. There is a risk of accident. Adapt your driving style to the traffic conditions. Observe the traffic situation and intervene actively if the situation warrants it.

WARNING

Due to system limitations, individual functions may not work properly when tow-starting/towing with activated Intelligent Safety Systems. There is a risk of accident. Switch off all Intelligent Safety Systems before tow-starting/towing.

Overview

Button in the vehicle



 Intelligent Safety button

Switching on/off

Some Intelligent Safety Systems are automatically active at the start of each journey. Some Intelligent Safety Systems are activated depending on their last setting.

 Press the button briefly:

- ▶ The menu for the Intelligent Safety Systems is shown. The systems are switched off individually depending on the individual setting.
- ▶ The LED illuminates orange or is extinguished, depending on the individual setting.

Press the button twice if necessary to switch off the collision warning.

Settings can be performed. The individual settings are saved for the current profile.



Press the button again:

- ▶ All Intelligent Safety Systems are switched on.
- ▶ The LED is illuminated green.



Press and hold down the button:

- ▶ All Intelligent Safety Systems are switched off.
- ▶ The LED is extinguished.

Collision warning with light city braking function

Principle

The system can help avoid accidents. If an accident cannot be avoided, the system helps to reduce the speed of impact.

The system warns of the possible risk of collision and brakes automatically, as necessary.

The automatic braking intervention is done with limited force and duration.

The system is controlled by a camera in the area of the interior mirror.

The collision warning is operational even if Cruise Control is disabled.

When deliberately moving closer to a vehicle, the collision warning and braking intervention are activated later to avoid unwarranted system responses.

General

From speeds of approximately 5 km/h, 3 mph, the system provides a two-stage warning of any possible risk of collision with vehicles. The timing of these warnings may vary depending on the current driving situation.

A brake intervention may take place. Depending on the equipment and national-market version, the brake intervention takes place at speeds of up to approximately 60 km/h, 35 mph or up to approximately 80 km/h, 50 mph.

Safety notes

WARNING

The system does not relieve you of your personal responsibility to assess the visibility conditions and traffic situation correctly. There is a risk of accident. Adapt your driving style to the traffic conditions. Observe the traffic situation and intervene actively if the situation warrants it.

WARNING

Displays and warnings do not relieve you of your personal responsibility. System limitations can mean that warnings or system responses are not issued or are issued too late, incorrectly or without justification. There is a risk of accident. Adapt your driving style to the traffic conditions. Observe the traffic situation and intervene actively if the situation warrants it.

WARNING

Due to system limitations, individual functions may not work properly when tow-starting/towing with activated Intelligent Safety Systems. There is a risk of accident. Switch off all Intelligent Safety Systems before tow-starting/towing.

Overview

Button in the vehicle



 Intelligent Safety button

Camera

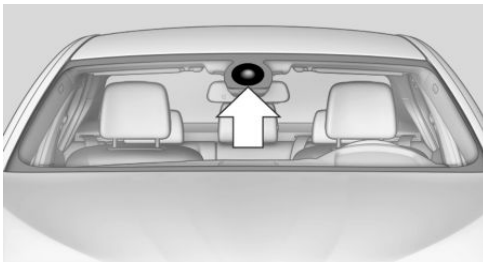

The camera is located near the interior mirror.
Keep the windscreen clean and clear in this area.

Detection range

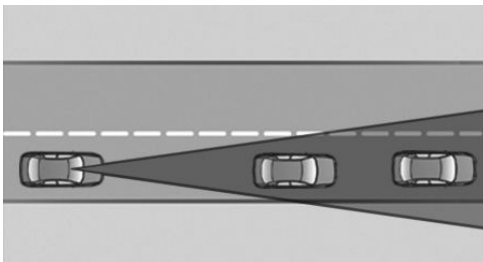

Objects detected by the system are taken into account.

Switching on/off

Automatic activation

The system is automatically activated at the start of each journey.

Switching on/off manually



Press the button briefly:

- ▶ The menu for the Intelligent Safety Systems is shown. The systems are switched off individually depending on the individual setting.
- ▶ The LED illuminates orange or is extinguished, depending on the individual setting.

Press the button twice if necessary to switch off the collision warning.

Settings can be performed. The individual settings are saved for the current driver profile.



Press the button again:

- ▶ All Intelligent Safety Systems are switched on.
- ▶ The LED is illuminated green.



Press and hold down the button:

- ▶ All Intelligent Safety Systems are switched off.
- ▶ The LED is extinguished.

Setting the warning time

The warning time can be set.

Via iDrive:

1. "My Vehicle"
2. "Vehicle settings"
3. "Intelligent Safety"
4. "Warning point"
5. Select the desired setting.

The selected time is saved for the current profile.

Warning with braking function

Display

If there is a risk of collision with a detected vehicle, a warning symbol is shown in the instrument cluster and in the Head-Up Display.

Symbol	Action
	Symbol illuminates red: advance warning. Brake and increase the distance.
	Symbol flashes red and an acoustic signal sounds: acute warning. Brake and take evasive action if necessary.



Advance warning

An advance warning is given for example if there is an impending risk of collision or the distance from the vehicle ahead is very short.

The driver must intervene personally when an advance warning is given.

Acute warning with braking function

An acute warning is given when the vehicle is approaching another object at a high differential speed and there is an immediate risk of a collision.

The driver must intervene personally when an acute warning is given. If necessary, the driver is assisted by slight automatic brake intervention if there is a risk of collision.

An acute warning can be triggered even without a previous advance warning.

Brake intervention

The warning prompts the driver to take action. Maximum braking force is used when the brakes are applied during a warning. Braking force support requires the brake pedal to be pressed sufficiently quickly and firmly. The system can also assist by applying the brakes lightly if there is the

risk of a collision. At low speeds, the vehicle can be braked to a stop.

Manual transmission: when the vehicle is braked to a stop, the engine may shut off.

A brake intervention can be discontinued either by pressing the accelerator pedal or by actively moving the steering wheel.

Object detection may be limited. Take into account the detection range limits and the functional limitations.

System limits

Safety note

WARNING

The system may not respond at all, or may respond too late, incorrectly or without justification due to system limitations. There is a risk of accident or material damage. Observe the information on the system limits and intervene actively if necessary.

Detection range

The detection ability of the system is limited.

For this reason, the system may fail to respond or only respond after a delay.

For example it is possible that the following may not be detected:

- ▶ Slow-moving vehicle when approaching it at high speed.
- ▶ Vehicles suddenly cutting in or braking heavily.
- ▶ Vehicles with an unusual rear appearance.
- ▶ Two-wheeled vehicles ahead.

Functional limitations

The system may have limited functionality in the following situations, for example:

- ▶ In thick fog, wet conditions or snow.
- ▶ On sharp bends.

- ▶ If vehicle stability control systems are deactivated, for example DSC OFF.
- ▶ If the field of view of the camera in the mirror is soiled or covered.
- ▶ Up to 10 seconds after starting the engine using the Start/Stop button.
- ▶ During the camera calibration process immediately after vehicle delivery.
- ▶ If there is sustained glare due to oncoming light, for example if the sun is low in the sky.

Sensitivity of the warnings

The higher the sensitivity of the warning settings, for example warning time, the more warnings are displayed. As a result, there may also be an increased number of premature or unjustified warnings and responses.

Person warning with city braking function

Principle

The system can help to avoid accidents with pedestrians.

The system warns of the possible risk of collision with pedestrians in the urban speed range and also has a braking function.

The system is controlled by the camera located near the interior mirror.

General

Provided that the light conditions are sufficiently bright, the system operates and issues warnings from approximately 10 km/h, 6 mph up to approximately 60 km/h, 35 mph if there is a risk of collision with pedestrians and provides assistance by briefly applying the brakes before a collision.

Persons are taken into account if they are located within the detection range of the system.

Safety notes

WARNING

The system does not relieve you of your personal responsibility to assess the visibility conditions and traffic situation correctly. There is a risk of accident. Adapt your driving style to the traffic conditions. Observe the traffic situation and intervene actively if the situation warrants it.

WARNING

Displays and warnings do not relieve you of your personal responsibility. System limitations can mean that warnings or system responses are not issued or are issued too late, incorrectly or without justification. There is a risk of accident. Adapt your driving style to the traffic conditions. Observe the traffic situation and intervene actively if the situation warrants it.

WARNING

Due to system limitations, individual functions may not work properly when tow-starting/towing with activated Intelligent Safety Systems. There is a risk of accident. Switch off all Intelligent Safety Systems before tow-starting/towing.

Overview

Button in the vehicle





Intelligent Safety button

Camera

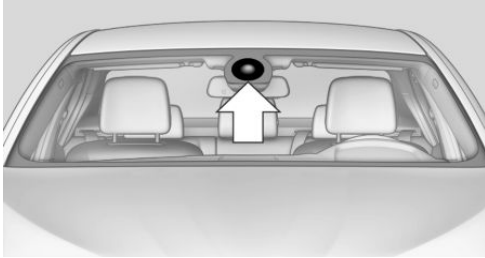

The camera is located near the interior mirror. Keep the windscreen clean and clear in this area.

Detection range

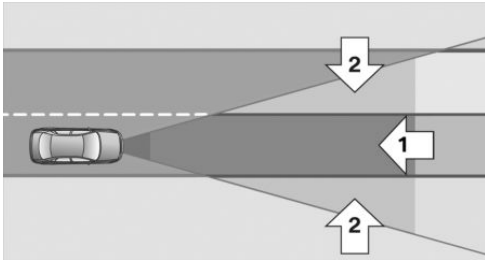

The detection zone in front of the vehicle consists of two parts:

- ▶ Central zone, arrow 1, directly in front of the vehicle.
- ▶ Extended zone, arrows 2, to the right and left of the central area.

There is a risk of collision if persons are in the central zone. A warning is only given if persons are in the extended zone if they are moving towards the central zone.

Switching on/off

Automatic activation

The system is automatically activated at the start of each journey.

Switching on/off manually



Press the button briefly:

- ▶ The menu for the Intelligent Safety Systems is shown. The systems are switched off individually depending on the individual setting.
 - ▶ The LED illuminates orange or is extinguished, depending on the individual setting.
- Press the button twice if necessary to switch off the collision warning.

Settings can be performed. The individual settings are saved for the current driver profile.



Press the button again:

- ▶ All Intelligent Safety Systems are switched on.
- ▶ The LED is illuminated green.



Press and hold down the button:

- ▶ All Intelligent Safety Systems are switched off.
- ▶ The LED is extinguished.

Warning with braking function

Display

If there is a risk of collision with a detected person, a warning symbol is shown in the instrument cluster and in the Head-Up Display.



A red symbol is displayed and an acoustic warning sounds.

Take action yourself immediately by braking or swerving.

Brake intervention

The warning prompts the driver to take action. Maximum braking force is used when the brakes are applied during a warning. Braking force support requires the brake pedal to be pressed sufficiently quickly and firmly. The system can also assist by applying the brakes lightly if there is the

risk of a collision. At low speeds, the vehicle can be braked to a stop.

Manual transmission: when the vehicle is braked to a stop, the engine may shut off.

A brake intervention can be discontinued either by pressing the accelerator pedal or by actively moving the steering wheel.

Object detection may be limited. Take into account the detection range limits and the functional limitations.

System limits

Safety note

WARNING

The system may not respond at all, or may respond too late, incorrectly or without justification due to system limitations. There is a risk of accident or material damage. Observe the information on the system limits and intervene actively if necessary.

Detection range

The detection capacity of the camera is limited.

As a result, the system may fail to give warnings or may give warnings late.

For example it is possible that the following may not be detected:

- ▷ Partially concealed pedestrians.
- ▷ Pedestrians who are not detected as such due to the viewing angle or outline.
- ▷ Pedestrians outside the detection range.
- ▷ Pedestrians shorter than approximately 80 cm, 32 in.

Functional limitations

The system may have limited functionality in some situations, for example:

- ▷ In thick fog, wet conditions or snow.
- ▷ On sharp bends.

- ▷ If vehicle stability control systems are deactivated, for example DSC OFF.
- ▷ If the field of view of the camera or the windscreen is soiled or covered.
- ▷ Up to 10 seconds after starting the engine using the Start/Stop button.
- ▷ During the camera calibration process immediately after vehicle delivery.
- ▷ If there is sustained glare due to oncoming light, for example if the sun is low in the sky.
- ▷ In the dark.

Lane Departure Warning

Principle

The Lane Departure Warning issues a warning if the vehicle leaves its lane on a road with lane markings.

General

Depending on the national-market version, the system issues a warning at speeds between 55 km/h, 35 mph and 70 km/h, 45 mph.

Warnings are issued in the form of steering wheel vibrations. The timing of this warning may vary depending on the current driving situation.

The system does not issue a warning if the driver indicates before leaving the driving lane.

Safety notes

WARNING

The system does not relieve you of your personal responsibility to assess the layout of the road and the traffic situation. There is a risk of accident. Adapt your driving style to the traffic conditions. Observe the traffic situation and intervene actively if the situation warrants it. In the event of a warning, do not move the steering wheel unnecessarily abruptly.

⚠ WARNING

Displays and warnings do not relieve you of your personal responsibility. System limitations can mean that warnings or system responses are not issued or are issued too late, incorrectly or without justification. There is a risk of accident. Adapt your driving style to the traffic conditions. Observe the traffic situation and intervene actively if the situation warrants it.

Overview**Button in the vehicle**

Intelligent Safety button

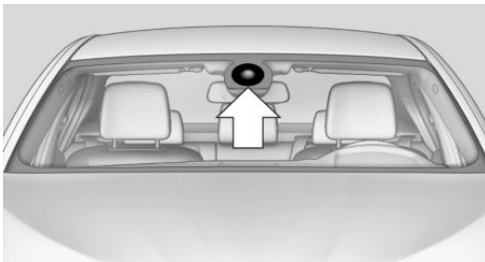
Camera

The camera is located near the interior mirror. Keep the windscreen clean and clear in this area.

Switching on/off**Automatic activation**

The Lane Departure Warning is reactivated automatically at the start of a journey if the function was switched on during the last period when the engine was stopped.

Switching on/off manually

Press the button briefly:

- ▶ The menu for the Intelligent Safety Systems is shown. The systems are switched off individually depending on the individual setting.
- ▶ The LED illuminates orange or is extinguished, depending on the individual setting.

Press the button twice if necessary to switch off the collision warning.

Settings can be performed. The individual settings are saved for the current driver profile.



Press the button again:

- ▶ All Intelligent Safety Systems are switched on.
- ▶ The LED is illuminated green.



Press and hold down the button:

- ▶ All Intelligent Safety Systems are switched off.
- ▶ The LED is extinguished.

Display in the instrument cluster

- ▶ Yellow symbol: system is activated.
- ▶ Green symbol: at least one lane marking has been detected and warnings can be issued.

Output of the warning

When leaving the lane

If the vehicle leaves the lane and a lane marking is detected, the steering wheel vibrates.

If the turn indicator is activated before changing lanes, no warning is issued.

Cancellation of the warning

The warning is cancelled in the following situations:

- ▶ Automatically after approximately 3 seconds.
- ▶ On returning to the correct lane.
- ▶ If the vehicle is braking heavily.
- ▶ On indicating.

System limits

Safety note

WARNING

The system may not respond at all, or may respond too late, incorrectly or without justification due to system limitations. There is a risk of accident or material damage. Observe the information on the system limits and intervene actively if necessary.

Functional limitations

The system may have limited functionality in the following situations, for example:

- ▶ In thick fog, wet conditions or snow.
- ▶ If there are missing, worn, poorly visible, merging/separating or ambiguous boundary lines, for example at road works.
- ▶ If boundary lines are covered by snow, ice, dirt or water.
- ▶ On sharp bends or narrow roads.
- ▶ If the boundary lines are not white.
- ▶ If boundary lines are obscured.

- ▶ If the vehicle is too close to the vehicle ahead.
- ▶ With bright oncoming light.
- ▶ If the area of windscreen in front of the interior mirror is covered with condensation, dirt, stickers, labels, etc.
- ▶ During the camera calibration process immediately after vehicle delivery.

Manual speed limiter

Principle

The system can be used to set a speed limit so that speed restrictions are not exceeded.

General

The system allows speeds of 30 km/h/20 mph and above to be set as a speed limit. Below the set speed limit, the vehicle can be driven without restriction.

Exceeding the speed limit

In particular situations the speed limit can be deliberately exceeded by accelerating strongly.

The system gives a warning if the vehicle's speed exceeds the set speed limit.



No brake intervention

If the set speed limit is reached or unintentionally exceeded, for example when driving downhill, there is no active brake intervention.

If you set a speed limit during the journey which is below the current speed, the vehicle rolls until the driving speed drops below the speed limit.

Overview

Buttons on the steering wheel

Button	Function
	Switching the system on/off, see page 172.
	Rocker switch: Changing the speed limit, see page 172.

Operation

Switching on

LIM Press the button on the steering wheel.

The current speed is adopted as the speed limit. When switching on when at a standstill or driving at low speed, 30 km/h/20 mph is set as the speed limit.

The status display is shown and, depending on the instrument cluster, a marking in the speedometer is set to the corresponding speed.

When activating the speed limit it is possible that Dynamic Stability Control DSC will be switched on and the drive mode switched to COMFORT.

Switching off

LIM Press the button on the steering wheel.

The system switches off automatically in the following situations, for example:

- ▷ When engaging reverse gear.
- ▷ When switching the engine off.
- ▷ When switching on Cruise Control.
- ▷ When activating some programs using the Driving Experience Control.

The displays turn off.

Changing the speed limit

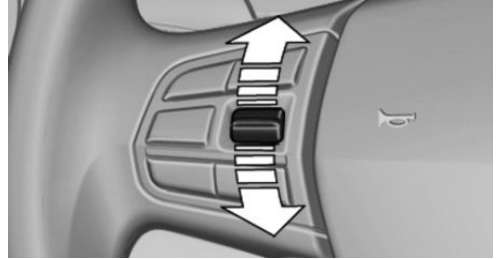

Press the rocker switch repeatedly up or down until the desired speed is set.

- ▷ Every time the rocker switch is pressed to the resistance point, the speed limit is increased or decreased by 1 km/h, 1 mph.
- ▷ Each time the rocker switch is pressed beyond the resistance point, the speed limit is increased or decreased to the next multiple of 10 km/h/5 mph on the speedometer display.

If you set a speed limit while driving which is below the current speed, the vehicle rolls to the set speed limit.

Exceeding the speed limit

You can intentionally exceed the speed limit. There is no acoustic warning in such a case.

To exceed the set speed limit intentionally, fully depress the accelerator pedal.

The limit automatically becomes active again as soon as the current speed falls below the set speed limit.

Warning when the speed limit is exceeded

Visual warning

LIM The indicator lamp in the instrument cluster flashes if the set speed limit is exceeded for as long as you exceed the set speed limit.

Acoustic warning

- ▷ A signal sounds if you inadvertently exceed the set speed limit.
- ▷ If the speed limit is reduced to below the driven speed during the journey, the warning sounds after approximately 30 seconds.
- ▷ If you intentionally exceed the speed limit by fully pressing the accelerator pedal, no warning is given.

Displays in the instrument cluster

Marking of the speed limit

Display in the speedometer:



- ▷ Marker illuminates green: the system is active.
- ▷ Marker not illuminated: the system is switched off.

Indicator lamp



- ▷ Indicator lamp illuminates: the system is switched on.
- ▷ Indicator lamp flashes: set speed limit is exceeded.

Status display



Display of the set speed limit.

Dynamic brake lights

Principle

The brake lights flash to warn road users behind the vehicle that an emergency braking manoeuvre is being performed. This can reduce the risk of a rear-end collision.

General

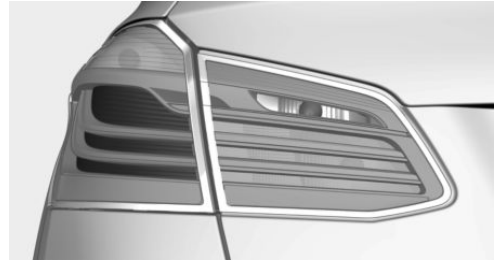

- ▷ Normal braking: brake lights illuminate.
- ▷ Heavy braking: brake lights flash.

Shortly before the vehicle comes to a standstill, the hazard warning lights are activated.

To deactivate the hazard warning lights:

- ▷ Accelerate.
- ▷ Press the hazard warning lights button.

Attentiveness Assistant

Principle

The system can detect decreasing attentiveness or the onset of fatigue in the driver on long monotonous journeys, for example on motorways. In such situations, the system recommends taking a break.

Safety note

WARNING

The system does not relieve you of your personal responsibility to assess your physical condition correctly. Increasing inattention or fatigue might not be detected, or may not be detected in good time. There is a risk of accident. Make sure that the driver is rested and alert. Adapt your driving style to the traffic conditions.

Function

The system is switched on every time the engine is started and cannot be switched off.

After commencement of the journey, the system adapts to the driver so that any decrease in attention or fatigue can be detected.

This process considers the following criteria:

- ▷ Personal driving style, for example steering.
- ▷ Driving conditions, for example time of day, duration of journey.

The system is active from approximately 70 km/h, 43 mph and can display a recommendation to take a break.

Break recommendations

If the driver shows signs of decreasing attentiveness or of fatigue, a message is shown on the control display with the recommendation to take a break.

A recommendation to take a break will only be displayed once during an uninterrupted journey.

After a break, another break recommendation cannot be displayed until after approximately 45 minutes at the earliest.

System limits

The system may have limited functionality, or give no warnings at all, in situations such as the following:

- ▷ If the time is set incorrectly.
- ▷ When the speed is predominantly below approx. 70 km/h, 43 mph.
- ▷ If a sporty driving style is adopted, for example sharp acceleration or fast cornering.
- ▷ In active driving situations, for example frequent lane changes.
- ▷ In poor road conditions.
- ▷ In strong crosswinds.

The system is reset approximately 45 minutes after the vehicle is stopped, for example when taking a break during a long motorway journey.

PostCrash – iBrake

Principle

In certain accident situations, the system can automatically bring the vehicle to a standstill without involvement of the driver. The risk of a further collision and its consequences can thereby be reduced.

Harder vehicle braking

In certain situations, it may be necessary to bring the vehicle to a standstill more quickly than is possible with automatic braking.

To do so, brake quickly and firmly. For a brief period, the braking pressure will be higher than that achieved with the automatic braking function. This action interrupts the automatic braking process.

Cancelling automatic braking

In certain situations, it may be necessary to cancel the automatic braking, such as for an evasive action.

Cancel automatic braking:

- ▷ By depressing the brake pedal.
- ▷ By depressing the accelerator pedal.

At a standstill

Once the vehicle has come to a halt, the brake is released automatically.

Driving Stability Control Systems

Vehicle equipment

This chapter describes all standard, country-specific and optional equipment available for the model series. It may therefore describe equipment and functions which are not installed in your vehicle, for example on account of the optional equipment selected or the national-market version. This also applies to safety-relevant functions and systems. Please comply with the relevant laws and regulations when using the corresponding functions and systems.

Anti-lock Brake System ABS

ABS prevents the wheels from locking when the brakes are applied.

Steering control is retained even during full braking, which enhances active road safety.

ABS is operational each time the engine is started.

Brake assist

When the brake is pressed quickly, this system automatically applies maximum braking power assistance. This keeps the stopping distance as short as possible in full braking situations. The advantages offered by the Anti-lock Brake System ABS are also utilised.

The pressure on the brake should be maintained for the duration of the full-braking process.

Dynamic Stability Control DSC

Principle

The system reduces engine power output and applies the brakes on individual wheels thereby helping, within the bounds of physics, to keep the vehicle safely on course.

General

DSC detects the following unstable driving conditions, for example:

- ▷ Loss of traction at the rear which can lead to oversteer.
- ▷ Loss of grip at the front wheels which can lead to understeer.

Dynamic Traction Control DTC, see page 176, is a variant of DSC which is for forward momentum.

Safety notes

WARNING

The system does not relieve you of your personal responsibility to assess the traffic situation correctly. Due to system limitations, it cannot respond independently and appropriately in all traffic conditions. There is a risk of accident. Adapt your driving style to the traffic conditions. Observe the traffic situation and intervene actively if the situation warrants it.

WARNING

When driving with a roof load, for example with a roof rack, the higher centre of gravity can mean that driving safety is no longer guaranteed in critical driving situations. There is a risk

of accident or material damage. Do not deactivate Dynamic Stability Control DSC when driving with a roof load.

Overview

Button in the vehicle



DSC OFF button

Indicator and warning lamps



Indicator lamp flashes: DSC is regulating the acceleration and braking forces.

Indicator lamp illuminates: DSC has

failed.

Deactivating DSC: DSC OFF

General

Driving stability during acceleration and cornering is restricted if DSC is deactivated.

To assist driving stability, re-activate DSC as soon as possible.

Deactivating DSC



Press and hold the button – but for no longer than approximately 10 seconds – until the DSC OFF indicator lamp in the instrument cluster is illuminated and DSC OFF is displayed.

DSC is switched off.

Activating DSC



Press the button.

DSC OFF and the DSC OFF indicator lamps are extinguished.

Indicator and warning lamps

DSC OFF is displayed in the instrument cluster when DSC is deactivated.



Indicator lamp illuminates: DSC is deactivated.

Automatic activation

If DSC is deactivated, it is automatically activated in the following situations:

- ▶ In the event of a flat tyre.
- ▶ If Cruise Control is activated in TRACTION mode or with DSC OFF.

Dynamic Traction Control DTC

Principle

DTC is a variant of Dynamic Stability Control DSC and is optimised for forward momentum.

In special road conditions, for example on uncleared, snow-covered roads or on loose surfaces, the system ensures maximum forward momentum, but with restricted driving stability.

Activating DTC provides maximum traction. Driving stability during acceleration and cornering is reduced.

Drive carefully.

It may be useful to activate DTC briefly in the following exceptional situations:

- ▶ When driving in slush or on uncleared, snow-covered roads.
- ▶ When starting in deep snow or on a loose surface.
- ▶ When driving with snow chains.

Deactivating/activating Dynamic Traction Control DTC

Activating DTC



Press the button.

TRACTION is displayed in the instrument cluster and the DSC OFF indicator lamp is illuminated.

Deactivating DTC



Press the button again.

TRACTION and the DSC OFF indicator lamp are extinguished.

Performance Control

Performance Control increases the agility of the vehicle.

Individual wheels are braked to increase agility for a sporty driving style.

xDrive

xDrive is the all-wheel system of the vehicle. The combination of xDrive and Dynamic Stability Control DSC further optimises traction and driving dynamics. The xDrive all-wheel system distributes the drive forces variably to the front and rear axles according to the driving situation and road surface conditions.

Servotronic

Principle

Servotronic is a speed-dependent power steering system.

The system provides more steering force assistance at lower speeds than at higher speeds. This makes it easier to park, for example, and

provides a firmer steering feel when driving at higher speeds.

In addition, the steering force is adapted according to the transmission mode, so that a firm, sporty feel or a comfortable steering response is conveyed.

Variable sport steering

The support offered by the variable sport steering changes according to the angle by which the steering wheel has been turned and the speed.

So, for example the steering angle of the front wheels is made larger when parking or taking tight corners. This makes it easier to drive around bends.

Furthermore, the system provides the steering with more support at low speeds than at higher speeds. This makes it easier to park, for example, and provides a more direct steering feel when driving at higher speeds.

By taking both steering wheel angle and vehicle speed into account, it has been possible to achieve a sport steering response adapted to the particular driving situation.

Driving Experience Control

Principle

The Driving Experience Control allows certain vehicle characteristics to be adapted. Various programs can be selected for this purpose.

Overview

Button in the vehicle

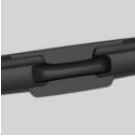
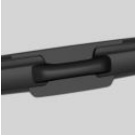
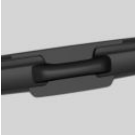

Operating the programs

Button	Program
	SPORT
	COMFORT
	ECO PRO

SPORT

Principle

A consistently sporty steering and drive system configuration for higher agility when driving.

If the vehicle is appropriately equipped, the suspension set-up additionally changes and SPORT can be individually configured.

The configuration is saved for the current profile.

Activating SPORT



Press the button until SPORT is displayed in the instrument cluster.

Configuring SPORT

Via iDrive:

1. "My Vehicle"
2. "Vehicle settings"
3. If necessary, "Driving mode"
4. "Configure SPORT"
5. Select the desired setting.

The setting is saved for the current driver profile.

This configuration is called up when the SPORT drive mode is activated.

COMFORT

Principle

For a balanced set-up.

Activating COMFORT



Press the button until COMFORT is displayed in the instrument cluster.

ECO PRO

Principle

ECO PRO, see page 246, offers a consistently efficient driving setting, in order to achieve maximum range.

Activating ECO PRO



Press the button until ECO PRO is displayed in the instrument cluster.

Configuring ECO PRO

Via iDrive:

1. "My Vehicle"
2. "Vehicle settings"
3. If necessary, "Driving mode"

4. "Configure ECO PRO"
5. Select the desired setting.

The setting is saved for the current driver profile.

Displays

Program selection

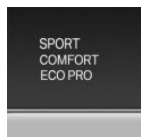

When the button is pressed, a list of selectable programs is shown. Depending on the equipment, the list in the instrument cluster may differ from the illustration.

Selected program

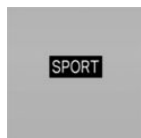

The selected program is shown in the instrument cluster.

Adaptive suspension

Principle

The system enables the suspension set-up to be changed.

Programs

It provides different programs.

The programs can be selected via the Driving Experience Control, see page [177](#).

SPORT

A consistently sporty shock absorber set-up for greater agility when driving.

COMFORT/ECO PRO

Balanced shock absorber set-up for greater comfort.

Drive-off assistant

Principle

The system provides support when driving off on upward gradients. It dispenses with the need to use the parking brake for this.

Driving off with drive-off assistant

1. Hold the vehicle in place with the foot brake.
2. Release the foot brake and drive off without delay.

After the foot brake is released, the vehicle is held in place for approximately 2 seconds.

Depending on the vehicle's load or when towing a trailer, the vehicle may roll backwards a little.

Driving comfort

Vehicle equipment

This chapter describes all standard, country-specific and optional equipment available for the model series. It may therefore describe equipment and functions which are not installed in your vehicle, for example on account of the optional equipment selected or the national-market version. This also applies to safety-relevant functions and systems. Please comply with the relevant laws and regulations when using the corresponding functions and systems.

Camera-based Cruise Control with Stop&Go function, ACC

Principle

This system allows you to set a desired speed and a desired distance from the vehicle in front, using the buttons on the steering wheel.

When the road ahead is clear, the system maintains the desired speed. The vehicle accelerates or brakes automatically.

If there is a vehicle driving in front, the system adapts the speed of your vehicle in order to maintain the set distance from the vehicle ahead. The speed is adapted as far as the given situation allows.

The distance can be set in several stages and for safety reasons is dependent on the respective speed.

If the vehicle ahead brakes to a standstill and sets off again shortly afterwards, the system is able to recognise this as far as the given conditions allow.

General

A camera on the interior mirror is used to detect a vehicle in front.

Depending on the vehicle setting, the characteristics of Cruise Control may change in certain areas.

Safety notes

WARNING

The system does not relieve you of your personal responsibility to assess the traffic situation correctly. Due to system limitations, it cannot respond independently and appropriately in all traffic conditions. There is a risk of accident. Adapt your driving style to the traffic conditions. Observe the traffic situation and intervene actively if the situation warrants it.

WARNING

An unsecured vehicle can start moving and rolling away. There is a risk of accident. Before leaving the vehicle, secure it to prevent it from rolling away.

Observe the following to ensure that the vehicle is secured against rolling away:

- ▷ Apply the parking brake.
- ▷ Turn the front wheels towards the kerb on upward or downward gradients.
- ▷ Additionally secure the vehicle on upward or downward gradients, for example with a chock.

⚠ WARNING

The desired speed may be set incorrectly by mistake or called up accidentally. There is a risk of accident. Adjust the desired speed to the traffic conditions. Observe the traffic situation and intervene actively if the situation warrants it.

⚠ WARNING

There is a risk of accident if the difference in speed relative to other vehicles is too great. This may occur, for example, in the following situations:

- ▷ When quickly approaching a slowly moving vehicle.
- ▷ If another vehicle suddenly veers into the vehicle's own lane.
- ▷ When quickly approaching stationary vehicles.

There is a risk of injury or even death. Observe the traffic situation and intervene actively if the situation warrants it.

Overview

Buttons on the steering wheel

Button Function

Cruise Control on/off, see page 181.



To interrupt Cruise Control, see page 181.

To resume Cruise Control with last setting, see page 183.



To reduce the distance, see page 183.

Button Function

To increase the distance, see page 183.



Rocker switch:
To set the speed, see page 182.

Camera

A camera in the area of the interior mirror is used to detect vehicles.

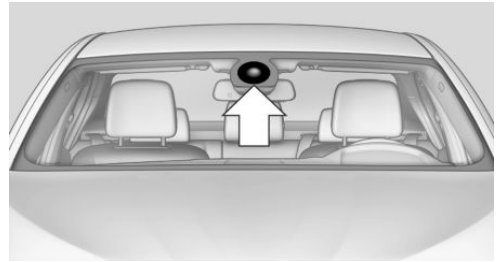

Keep the windscreen clean and clear in this area.

Operating requirements

The system can be used to optimum effect on well-constructed roads.

Any desired speed between 30 km/h/20 mph and 140 km/h/85 mph can be set.

Higher desired speeds can also be selected if distance control is switched off, see page 183.

The system can also be activated when the vehicle is at a standstill.

Switching Cruise Control on/off and interrupting

Switching on



Press the button on the steering wheel.

The indicator lamps are illuminated in the instrument cluster and the marker in the speedometer is positioned at the current speed.

Cruise Control is active and maintains the set speed.

Dynamic Stability Control DSC is switched on, if necessary.

Switching off

When switching off with the vehicle at a standstill, depress the brake pedal at the same time.



Press the button on the steering wheel.

The displays turn off. The stored desired speed is deleted.

Interrupting manually



Press the button on the steering wheel.

If interrupting the system when the vehicle is at a standstill, depress the brake pedal at the same time.

Interrupting automatically

The system is interrupted automatically in the following situations:

- ▶ If the driver brakes.
- ▶ If the selector lever is moved out of position D.
- ▶ If Dynamic Traction Control DTC is activated.
- ▶ If Dynamic Stability Control DSC intervenes.
- ▶ If the vehicle is stationary and the seat belt is unfastened and the driver's door is opened.
- ▶ If the detection zone of the camera is disrupted, for example, due to dirt, heavy rainfall or dazzling by the sun.
- ▶ After a stationary period of approximately 3 seconds, if the vehicle was decelerated by the system to a standstill.

Setting the speed

Maintaining, storing a speed

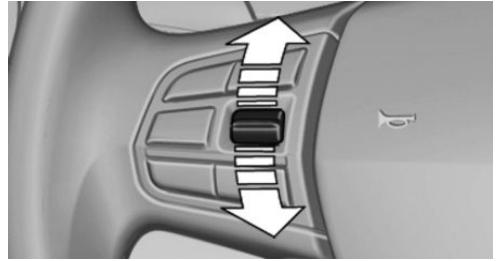

While the system is interrupted, press the rocker switch up or down once.

When the system is switched on, the current speed is maintained and stored as the desired speed.

The stored speed is displayed in the speedometer and briefly in the instrument cluster, see page 184.

Dynamic Stability Control DSC is switched on, if necessary.

Changing the speed

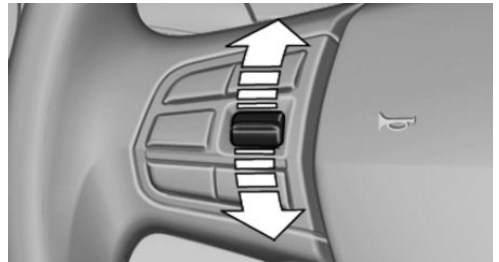

Press the rocker switch repeatedly up or down until the desired speed is set.

If the system is active, the displayed speed is stored and the vehicle adjusts to the stored speed when the road is clear.

- ▶ Each time the rocker switch is pressed to the resistance point, the desired speed is increased or decreased by approximately 1 km/h, 1 mph.

- ▷ Each time the rocker switch is pressed beyond the resistance point, the desired speed changes to the next multiple of 10 km/h/ 5 mph on the speedometer display.

To repeat an action, hold the rocker switch in the relevant position.

Adjusting the distance

Safety note

WARNING

The system does not relieve you of your personal responsibility. System limitations may mean that braking is performed too late. There is a risk of accident or material damage. Pay close attention to the traffic conditions at all times. Adapt the distance to suit traffic and weather conditions and comply with the prescribed safe distance by braking if necessary.

Reducing the distance



Press the button repeatedly until the desired distance is set.



The set distance is briefly displayed in the instrument cluster.

Increasing the distance



Press the button repeatedly until the desired distance is set.



The set distance is briefly displayed in the instrument cluster.

Resuming Cruise Control

General

If Cruise Control is interrupted, it can be resumed by calling up the stored speed.

Before calling up the stored speed, make sure that the difference between the current speed and the stored speed is not too great. Otherwise, there may be unintentional braking or acceleration.

In the following instances, the stored speed is deleted and therefore cannot be called up again:

- ▷ When the system is switched off.
- ▷ When the ignition is switched off.

Resuming the stored speed and distance



With the system interrupted, press the button. Cruise Control is resumed with the stored values. Selected speed is briefly displayed on Info Display.

Switching distance control off/on

Safety note

WARNING

The system does not respond to traffic traveling in front of you, but instead maintains the stored speed. There is a risk of accident or material damage. Adjust the desired speed to the traffic conditions and brake if necessary.

Switching distance control off

Distance control can be switched off and on when driving with Cruise Control activated.



Press and hold the button or



Press and hold the button.



The indicator lamp in the instrument cluster is illuminated.

Press the button again briefly to switch the distance control back on.

A Check Control message is displayed after changing over the distance control.

Displays in the instrument cluster

Desired speed and stored speed



- ▷ Marker illuminates green: system is active, the marker shows the desired speed.
- ▷ Marker illuminates orange: system is interrupted, the marker shows the stored speed.

- ▷ Marker not illuminated: the system is switched off.

Brief status display



Selected desired speed.

If no speed is displayed, it's possible that the conditions required for operation are not being met at the present time.

Vehicle distance

The selected distance to the vehicle ahead is displayed.

Distance indicator



Distance 1



Distance 2

Distance indicator



Distance 3

Selected automatically when the system is switched on. Corresponds to approximately half of the value of the speedometer reading, expressed in metres.



Distance 4

Detected vehicle



Symbol illuminates orange:
Vehicle ahead detected.



Rolling bars: the detected vehicle has driven off.

ACC does not accelerate. To accelerate, activate ACC by briefly pressing the accelerator pedal or pressing the RES CNCL button or rocker switch.

Indicator and warning lamps



Symbol flashes orange:
The requirements for system operation are no longer being met.

The system has been deactivated but will continue to brake until you actively take over by depressing the brake or accelerator pedal.



Symbol flashes red and an acoustic signal sounds:

The system prompts you brake and/or manoeuvre the vehicle yourself.



System interrupted or distance control briefly disabled because the accelerator pedal is pressed although a vehicle is not detected.



Distance control briefly disabled because the accelerator pedal is pressed while a vehicle is detected.

Displays in the Head-Up Display

Some information from the system can also be shown in the Head-Up Display.

System limits

Detection range

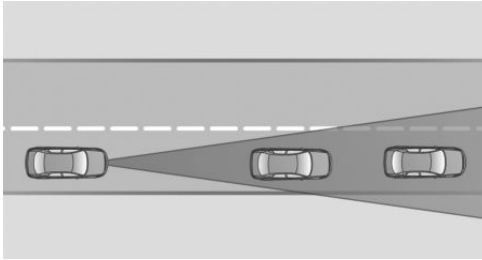

The system's detection capability and automatic braking capacity are limited.

For example two-wheeled vehicles may not be detected.

Deceleration

The system does not decelerate in the following situations:

- ▶ For pedestrians, cyclists or similar slow road users.
- ▶ For red traffic lights.
- ▶ For crossing traffic.
- ▶ For oncoming vehicles.
- ▶ For unlit vehicles or vehicles with faulty lighting at night.

Vehicles cutting in

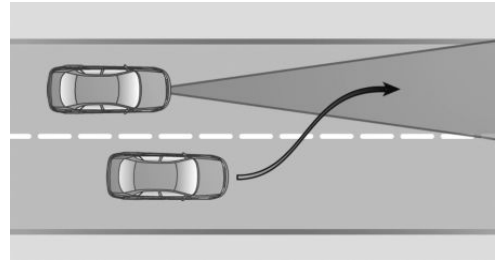

A vehicle driving ahead of you is only detected when it is fully in your driving path.

If another vehicle suddenly cuts in front of you, the system might not be able to restore the selected distance automatically. In some circumstances, it may also not be possible to restore the selected distance if you are driving significantly faster than vehicles in front, for example when rapidly approaching a lorry. If a vehicle is clearly detected in front of you, the system prompts you to intervene by braking, and if necessary by taking evasive action.

Cornering

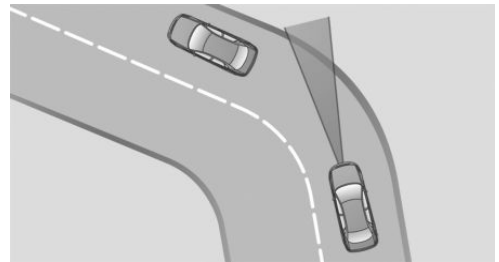

If the desired speed is too high for cornering, it will be reduced slightly in the bend. However, the system does not detect bends in advance. For this reason, moderate your speed when cornering.

The system has a limited detection range. Situations can arise on tight bends where a vehicle driving in front will not be detected or will be detected very late.

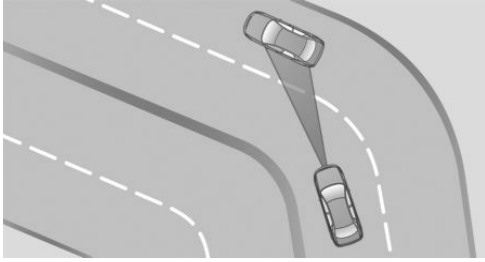

When your vehicle is approaching a bend, the angle of the bend may cause the system to respond temporarily to vehicles in the other lane. If the system responds by decelerating the vehicle, you may compensate for this by accelerating briefly. When the accelerator pedal is released again, the system will resume control of the vehicle's speed.

Driving off

The vehicle cannot drive off automatically in the following situations, for example:

- ▷ On steep upward gradients.
- ▷ Before bumps or rises in the road.
- ▷ When towing a heavy trailer.

In such cases, press the accelerator pedal.

Weather

In unfavourable weather and lighting conditions, system functionality may be limited as follows:

- ▷ Impaired detection of vehicles.
- ▷ Brief interruptions when vehicles have already been detected.

Examples of unfavourable weather or lighting conditions:

- ▷ Wet roads.
- ▷ Snowfall.
- ▷ Slush.
- ▷ Fog.
- ▷ Oncoming light.

Pay attention when driving and respond to the prevailing traffic conditions. If necessary, inter-

vene actively, for example by braking, steering or taking evasive action.

Engine power

The vehicle may drive slower than the desired speed on gradients, if the engine power is not sufficient.

Malfunction

A Check Control message is displayed if the system has failed or has been automatically deactivated.

The system may have limited functionality in the following situations, for example:

- ▷ If an object has not been correctly detected.
- ▷ In thick fog, rain, spray or snowfall.
- ▷ On sharp bends.
- ▷ If the field of view of the camera or the windscreen is soiled or covered.
- ▷ With bright oncoming light.
- ▷ Up to 20 seconds after starting the engine using the Start/Stop button.
- ▷ During the camera calibration process immediately after vehicle delivery.

Cruise Control

Principle

This system allows a desired speed to be set using the buttons on the steering wheel. The set speed is then maintained by the system. It does this by automatically accelerating and braking the vehicle as necessary.

General

Depending on the vehicle setting, the characteristics of Cruise Control may change in certain areas.

Safety notes

WARNING

The system does not relieve you of your personal responsibility to assess the traffic situation correctly. Due to system limitations, it cannot respond independently and appropriately in all traffic conditions. There is a risk of accident. Adapt your driving style to the traffic conditions. Observe the traffic situation and intervene actively if the situation warrants it.

WARNING

The risk of an accident may increase if the system is used in certain situations, such as:

- ▷ On stretches of road with many corners and bends.
- ▷ In heavy traffic.
- ▷ If the road is icy, if there is fog or snow, in wet conditions or on a loose road surface.



There is a risk of accident or material damage. Only use the system if it is possible to drive at a constant speed.

WARNING

The desired speed may be set incorrectly by mistake or called up accidentally. There is a risk of accident. Adjust the desired speed to the traffic conditions. Observe the traffic situation and intervene actively if the situation warrants it.

Overview

Buttons on the steering wheel

Button	Function
	Cruise Control on/off, see page 187.
	To interrupt Cruise Control, see page 187. To resume Cruise Control with last setting, see page 188.
	Rocker switch: To set the speed, see page 188.

Switching Cruise Control on/off and interrupting

Switching on

 Press the button on the steering wheel.

The speedometer marker is set to the current speed.

Cruise Control is active and maintains the set speed.

Dynamic Stability Control DSC is switched on, if necessary.

Switching off

 Press the button on the steering wheel.

The displays turn off. The stored desired speed is deleted.

Interrupting manually

 With the system active, press the button on the steering wheel.

Interrupting automatically

The system is interrupted automatically in the following situations:

- ▷ If the driver brakes.
- ▷ If the clutch is pressed for a few seconds or released with no gear engaged.
- ▷ If too high a gear has been engaged for the speed.
- ▷ If selector lever position N is engaged.
- ▷ If Dynamic Traction Control DTC is activated or Dynamic Stability Control DSC deactivated.
- ▷ If Dynamic Stability Control DSC intervenes.

Setting the speed

Maintaining, storing a speed

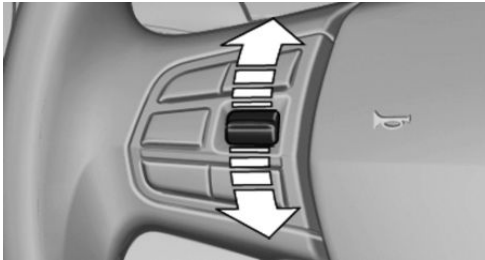

While the system is interrupted, press the rocker switch up or down once.

When the system is switched on, the current speed is maintained and stored as the desired speed.

The saved speed is displayed in the speedometer and in the instrument cluster, see page 189.

Dynamic Stability Control DSC is switched on, if necessary.

Changing the speed

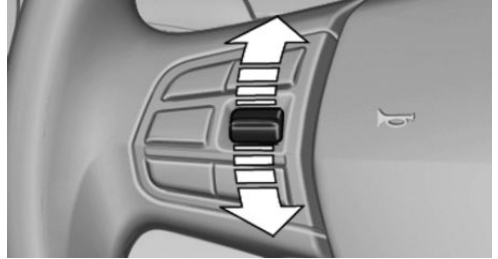

Press the rocker switch repeatedly up or down until the desired speed is set.

If the system is active, the displayed speed is stored and the vehicle adjusts to the stored speed when the road is clear.

- ▷ Each time the rocker switch is pressed to the resistance point, the desired speed is increased or decreased by approximately 1 km/h, 1 mph.
- ▷ Each time the rocker switch is pressed beyond the resistance point, the desired speed is increased or decreased to the next multiple of 10 km/h, 5 mph on the speedometer display.
- ▷ When the rocker switch is pressed to the resistance point and then held there: the vehicle accelerates or decelerates without the need to press the accelerator pedal.
When the rocker switch is released, the vehicle maintains the final speed. Pressing beyond the resistance point accelerates the vehicle more rapidly.

Resuming Cruise Control

General

If Cruise Control is interrupted, it can be resumed by calling up the stored speed.

Before calling up the stored speed, make sure that the difference between the current speed and the stored speed is not too great. Otherwise, there may be unintentional braking or acceleration.

In the following instances, the stored speed is deleted and therefore cannot be called up again:

- ▷ When the system is switched off.
- ▷ When the ignition is switched off.

Resuming a stored speed

 Press the button on the steering wheel.

The stored speed is resumed and maintained.

Displays in the instrument cluster

Indicator lamp



Depending on the equipment the indicator lamp in the instrument cluster shows whether the system is switched on.

Desired speed and stored speed



- ▷ Marker illuminates green: system is active, the marker shows the desired speed.
- ▷ Marker illuminates orange: system is interrupted, the marker shows the stored speed.
- ▷ Marker not illuminated: the system is switched off.

Status display



Selected desired speed.

If no speed is displayed, it's possible that the conditions required for operation are not being met at the present time.

Displays in the Head-Up Display

Some information from the system can also be shown in the Head-Up Display.

System limits

Engine power

The desired speed will also be maintained on downward gradients, but may not be reached on upward gradients if engine power is insufficient.

Park Distance Control PDC

Principle

PDC provides assistance when parking the vehicle. The system detects objects behind the vehicle. If the vehicle is equipped with front PDC, objects in front of the vehicle are detected too. Objects being approached slowly are indicated by acoustic signals and a display on the control display.

General

The ultrasonic sensors for measuring the distances are located in the bumpers.

Their range is approximately 2 m, 6 ft, depending on the obstacle and environment.

An acoustic warning is only issued in the following situations:

- ▷ For the front sensors and the two corner sensors at the rear at a distance of approximately 60 cm, 24 in from the object.
- ▷ At the middle sensors at the rear at a distance of approx. 1.50 m, 5 ft from the object.
- ▷ If there is a collision risk.

Safety notes

WARNING

The system does not relieve you of your personal responsibility to assess the traffic situation correctly. Due to system limitations, it cannot respond independently and appropriately in all traffic conditions. There is a risk of accident. Adapt your driving style to the traffic conditions.

Observe the traffic situation and intervene actively if the situation warrants it.

WARNING

Approaching at high speed when using Park Distance Control PDC may result in late warnings, due to the physical conditions. There is a risk of injury or material damage. Avoid approaching an object at speed. Avoid moving off at speed while Park Distance Control PDC is not yet active.

Overview

With front PDC: button in vehicle



 Park Assist button

Ultrasonic sensors



Ultrasonic sensors of the PDC, for example in the bumpers.

Operating requirements

To ensure full functionality:

- ▶ Do not cover sensors, for example by stickers, bicycle rack.
- ▶ Keep the sensors clean and unobstructed.

Switching on/off

Automatic activation

The system switches on automatically in the following situations:

- ▶ If selector lever position R is engaged while the engine is running.
 - The Reversing Assist camera also switches on.
- ▶ With front PDC equipment: if obstacles behind or in front of the vehicle are detected by PDC and the speed is slower than approximately 4 km/h, 2.5 mph.

Automatic activation on detection of obstacles can be enabled and disabled. Via iDrive:

1. "My Vehicle"
2. "Vehicle settings"
3. "Parking"
4. "Automatic PDC activation": depending on the equipment.
5. "Automatic PDC activation"
 - The setting is saved for the current driver profile.

To reduce false alarms, switch off automatic activation of PDC when obstacles are detected if necessary, for example in automatic car washes.

Automatic deactivation when moving forwards

The system switches off once a certain distance or speed is exceeded.

Switch the system back on if necessary.

With front PDC: switching on/off manually

 Press the Park Assist button.

- ▶ On: the LED is illuminated.
- ▶ Off: the LED is extinguished.

The image from the Reversing Assist camera is shown when reverse gear is engaged and the Park Assist button is pressed.

Depending on the equipment, the system cannot be switched off manually when reverse gear is engaged.

Warning

Acoustic signals

An intermittent sound indicates that the vehicle is approaching an object. For example, if an object is identified to the rear left of the vehicle, the acoustic signal is emitted from the rear left loud-speaker.

The shorter the distance to an object, the shorter the intervals become.

If the distance to a detected object is less than approximately 25 cm, 10 in, a continuous tone sounds.

With front PDC: if there are simultaneously objects in front of and behind the vehicle, an alternating continuous tone sounds.

The acoustic signal is switched off when selector lever position P is engaged on the Steptronic transmission.

Volume control

It is possible to adjust the volume of the PDC acoustic signal relative to the volume of the entertainment source playback.

Via iDrive:

1. "My Vehicle"
2. "iDrive settings"
3. "Sound"
4. "Volume settings"
5. "PDC"
6. Set the desired value.

The setting is saved for the current driver profile.

Visual warning



The vehicle's approach to an object is shown on the control display. Objects further away are shown before an acoustic signal is given.

The display appears as soon as PDC is activated.

The recording range of the sensors is shown in green, yellow and red.

If the Reversing Assist camera image is displayed, it is possible to change over to PDC:

1. If necessary, tilt the Controller to the left.
2.  "Rear view camera"

System limits

Safety note

WARNING

The system may not respond at all, or may respond too late, incorrectly or without justification due to system limitations. There is a risk of accident or material damage. Observe the information on the system limits and intervene actively if necessary.

With a trailer or when the trailer socket is in use

The rear PDC functions are switched off.

A Check Control message is displayed if corresponding equipment is fitted.

Limits of ultrasound measurement

The physical limits of ultrasound measurement may be reached when detecting objects in situations including the following:

- ▷ Small children and animals.
- ▷ Persons wearing certain types of clothing, for example a coat.
- ▷ External interference with the ultrasound, for example by passing vehicles or loud machines.
- ▷ Sensors which are dirty, iced up, damaged or incorrectly adjusted.
- ▷ Certain weather conditions, for example high humidity, wet conditions, snowfall, extreme heat or strong wind.
- ▷ Trailer drawbars and tow hitches of other vehicles.
- ▷ Thin or wedge-shaped objects.
- ▷ Moving objects.
- ▷ Higher protruding objects, for example projecting walls or loads.
- ▷ Objects with corners and sharp edges.
- ▷ Objects with fine surfaces or structures, for example fences.
- ▷ Objects with porous surfaces.
- ▷ When a projecting load is being transported.
- ▷ Low objects already indicated, for example kerbs, may enter the sensors' blind areas before or after a continuous tone is given.

False alarms

Under the following conditions, the system may issue a warning even though there is no obstacle in the detection range:

- ▷ In heavy rain.
- ▷ If the sensors are heavily soiled or covered with ice.
- ▷ If the sensors are covered with snow.
- ▷ On rough road surfaces.

- ▷ On uneven surfaces, for example speed bumps.
- ▷ In large, rectangular buildings with smooth walls, for example underground car parks.
- ▷ In washing bays and car washes.
- ▷ In the presence of dense exhaust fumes.
- ▷ If the cover of the trailer tow hitch is incorrectly seated.
- ▷ In the presence of other ultrasonic sources, for example sweeping machines, steam-jet cleaners or neon lights.

The malfunction is indicated by an alternating continuous tone from the front and rear loudspeakers.

The system is fully functional again once the interference from other ultrasound sources is no longer present.

To reduce false alarms, switch off automatic activation of PDC upon detection of obstacles where necessary, for example in automatic car washes.

Malfunction

A Check Control message is shown.

The capture area of the sensors is shown hatched on the control display.

PDC has failed. Have the system checked by a Service Partner of the manufacturer or another qualified Service Partner or a specialist workshop.

Reversing Assist camera

Principle

The Reversing Assist camera provides assistance when reverse parking or manoeuvring. It does this by displaying the area behind the vehicle on the control display.

Safety note

WARNING

The system does not relieve you of your personal responsibility to assess the traffic situation correctly. There is a risk of accident. Adapt your driving style to the traffic conditions. In addition, look directly to check the traffic situation and the area around the vehicle and intervene actively where appropriate.

Overview

Depending on the equipment: button in the vehicle



 Park Assist button

Camera

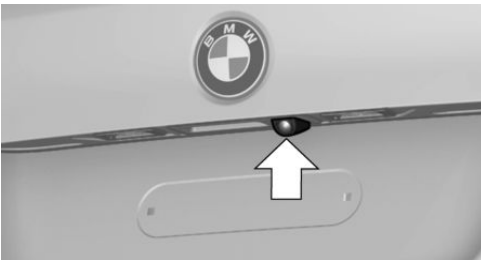

The lens of the camera is located in the handle strip of the tailgate.

Dirt can impair the quality of the image. Clean the camera lens if required.

Switching on/off

Automatic activation

The system automatically switches on when selector lever position R is engaged while the engine is running.

Automatic deactivation when moving forwards

The system switches off once a certain distance or speed is exceeded.

Switch the system back on if necessary.

Depending on the equipment: switching on/off manually



Press the Park Assist button.

- ▷ On: the LED is illuminated.
- ▷ Off: the LED is extinguished.

The parking assistance functions are shown on the control display.

Switching the view via iDrive

If the Reversing Assist camera view is not displayed, change the view via iDrive:

1. If necessary, tilt the Controller to the left.
2.  "Rear view camera"

The image from the Reversing Assist camera is shown.

Display on the control display

Operating requirements

- ▷ The Reversing Assist camera is switched on.
- ▷ The tailgate is completely closed.
- ▷ Keep the detection range of the camera clear. Projecting loads or carrier systems and trailers that are not connected to a trailer socket may cause malfunctions.

Activating assistance functions

A number of assistance functions can be active simultaneously.

The zoom function for towing a trailer can only be activated individually.

If necessary, tilt the Controller to the left.

▷ Parking guidance lines

 "Parking guidance lines"

Driving path lines and turning circle lines are shown.

▷ Obstacle marker

 "Obstacle marking"

Depending on the equipment, obstacles are highlighted.

▷ Trailer tow hitch

 "Towbar zoom"

A zoomed-in image of the trailer tow hitch is displayed.

Driving path lines

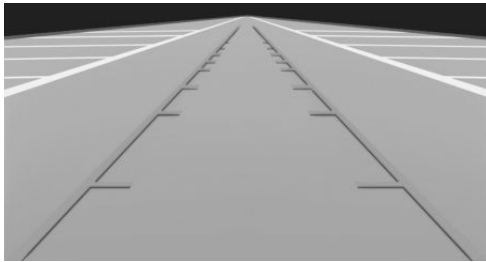

Driving path lines can be shown in the image from the Reversing Assist camera.

The driving path lines help you to estimate the space required when parking and manoeuvring on a level road surface.

The driving path lines are dependent on the steering angle and continuously adapt to steering wheel movements.

Turning circle lines

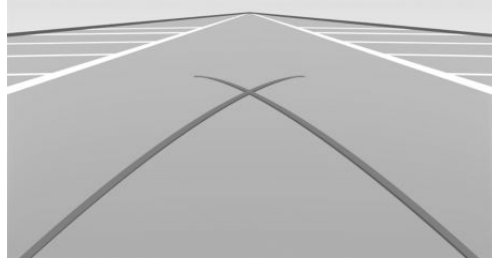

The turning circle lines can only be shown in the image from the Reversing Assist camera together with the driving path lines.

The turning circle lines show the trajectory of the smallest possible turning circle on a level road surface.

Once the steering wheel has been turned beyond a certain angle, only one turning circle line is displayed.

Obstacle marker

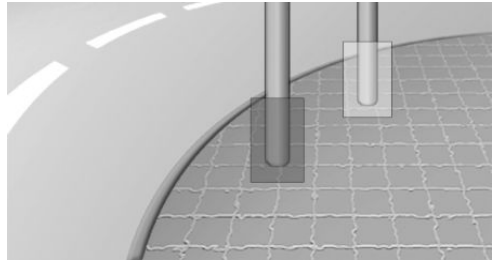

Depending on the equipment, obstacle markers can be shown in the image from the Reversing Assist camera.

The colour grading of the obstacle markings is the same as the Park Distance Control PDC markings.

Zoom to trailer tow hitch

To assist with connecting up a trailer, it is possible to zoom in on the area around the trailer tow hitch.



Two static circle segments show the distance between the trailer and the trailer tow hitch.

A docking line dependent on the steering angle assists you in lining up the trailer tow hitch with the trailer.

The zoom function can be enabled when the camera is switched on.

When zooming in, remember that the view might no longer show certain obstacles.

Parking with the help of driving path and turning circle lines

1. Position the vehicle so that the turning circle lines are within the boundaries of the parking space.

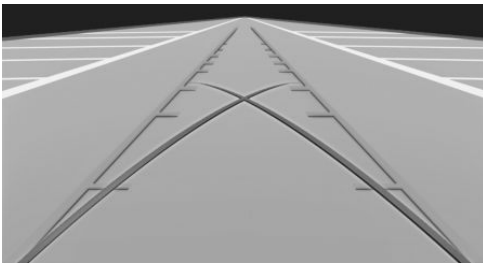

2. Turn the steering wheel so that the driving path line covers the corresponding turning circle line.

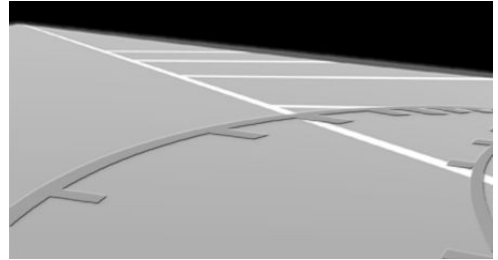

Display settings

Brightness

With Reversing Assist camera switched on:

1. If necessary, tilt the Controller to the left.
2. ☀️ Select the symbol.
3. Turn the Controller until the desired setting is reached and press the Controller.

Contrast

With Reversing Assist camera switched on:

1. If necessary, tilt the Controller to the left.
2. 🌑 Select the symbol.
3. Turn the Controller until the desired setting is reached and press the Controller.

System limits

Detection of objects

The system cannot detect very low obstacles and higher, protruding objects such as ledges.

Depending on the equipment, some assistance functions also take account of Park Distance Control PDC data.

Observe the notes in the chapter on Park Distance Control PDC.

The objects shown in the control display may be closer than they appear. Do not estimate the distance to objects based on the display.

Park Assist

Principle

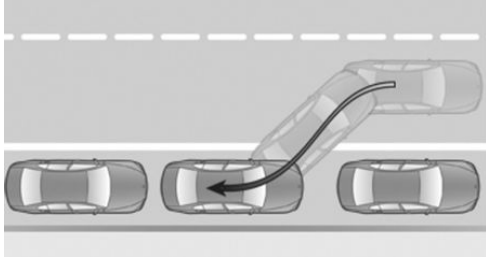

The system supports you when parking parallel to the road.

General

Operation of Park Assist is divided into three steps:

- ▷ Switching on and activating.
- ▷ Parking space search.
- ▷ Parking.

The status of the system and the actions required are shown on the control display.

Ultrasonic sensors measure parking spaces on both sides of the vehicle.

Park Assist calculates the ideal parking line and takes over steering during the process of parking.

Park Assist uses the sensors of the Park Distance Control, PDC. The safety information for Park Distance Control PDC also applies.

Safety notes

⚠ WARNING

The system does not relieve you of your personal responsibility to assess the traffic situation correctly. Due to system limitations, it cannot respond independently and appropriately in all traffic conditions. There is a risk of accident. Adapt your driving style to the traffic conditions. Observe the traffic situation and intervene actively if the situation warrants it.

⚠ WARNING

When the trailer tow hitch is in use, the assistance system could cause damage if its sensors are obstructed. There is a risk of accident or material damage. Do not use the assistance system when towing a trailer or when using the trailer tow hitch, for example with a bicycle carrier.

⚠ NOTE

Park Assist may steer across or up onto kerbs. There is a risk of material damage. Observe the traffic situation and intervene actively if the situation warrants it.

The safety information for Park Distance Control PDC also applies.

Overview

Button in the vehicle

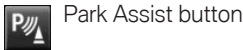
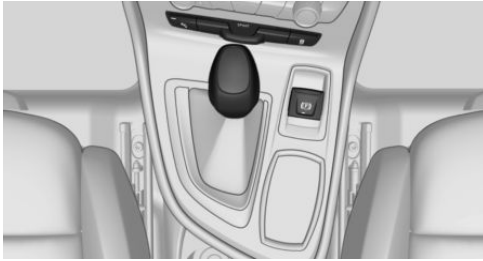

Park Assist button

Ultrasonic sensors

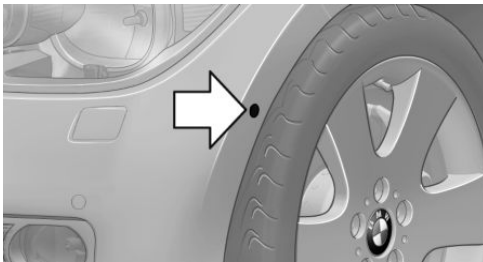

Ultrasonic sensors to measure parking spaces are located on side of vehicle.

Operating requirements

Ultrasonic sensors

To ensure full functionality:

- ▶ Do not cover the sensors, for example with stickers.
- ▶ Keep the sensors clean and unobstructed.

For measuring parking spaces

- ▶ Driving forwards in a straight line up to a maximum speed of approximately 35 km/h, 22 mph.
- ▶ Maximum distance from the row of parked vehicles: 1.5 m, 5 ft.

Suitable parking space

- ▶ Gap behind an object which is at least 1.5 m, 5 ft long.
- ▶ Gap between two objects, each at least 1.5 m, 5 ft long.
- ▶ Minimum length of gap between two objects: own vehicle length plus approximately 1.0 m, 3.3 ft.
- ▶ Minimum depth: approximately 1.5 m, 5 ft.

For parking

- ▶ Doors and tailgate closed.
- ▶ Parking brake released.
- ▶ You must indicate accordingly when parking into parking spaces on the driver's side.

Switching on and activating

Switching on with the button



- ▶ Press the Park Assist button.
- ▶ The LED is illuminated.

The current status of the parking space search is displayed on the control display.

 Park Assist is automatically activated.

Switching on with reverse gear



Engage reverse gear.

The current status of the parking space search is displayed on the control display.

To activate:  "Park Assist"

Display on the control display

System is activated/deactivated



Symbol	Meaning
	Grey: system not available. White: system available but not activated.
	System is activated.

Parking space search and system status



- ▶ Symbol P on the vehicle image: Park Assist is activated and the parking space search is active.
- ▶ Suitable parking spaces are shown on the control display along the edge of the road next to the vehicle symbol. Suitable parking spaces are highlighted in colour when Park Assist is active.
- ▶  Parking operation active. The system has taken over steering.
- ▶ The parking space search is active whenever the vehicle is driving forwards at low speed, even if the system is deactivated. If the system is deactivated, the displays on the control display are shown grey.

Parking with Park Assist

1.  Press the Park Assist button or engage reverse gear to switch on Park Assist, see page 197. Activate Park Assist if necessary.
 - ▶  Park Assist is activated.
2. Drive past the line of parked vehicles at a maximum speed of approximately 35 km/h, 22 mph and a maximum distance of 1.5 m, 5 ft.

The status of the parking space search and possible parking spaces are shown on the control display, see page 198.
3. Follow the instructions on the control display.



Park Assist takes over steering during the process of parking. The driver assumes responsibility for braking and accelerating.

For an optimum parking position, change gear while at standstill, then wait for the system to steer automatically.

Completion of parking is indicated on the control display.
4. Adjust the parking position yourself if necessary.

Cancelling manually

You can cancel Park Assist at any time:

- ▶  "Park Assist" Select the symbol on the control display.
- ▶  Press the Park Assist button.

Cancelling automatically

The system automatically cancels in the following situations:

- ▶ If the driver grips the steering wheel or steers the vehicle.
- ▶ When selecting gear, which does not correspond to the information on the display.
- ▶ At speeds over approximately 10 km/h, 6 mph.

- ▷ On snow-covered or slippery road surfaces, if necessary.
- ▷ When a maximum number of parking attempts or the parking time is exceeded.
- ▷ If Park Distance Control PDC shows gaps that are too small.
- ▷ If you switch to other functions on the control display.

A Check Control message is shown.

Resuming

You can continue a cancelled parking operation if applicable.

To do this, reactivate Park Assist, see page 197, and follow the instructions on the display.

Switching off

The system can be switched off as follows:

- ▷  Press the Park Assist button.
- ▷ Switch off the ignition.

System limits

Safety note

WARNING

The system may not respond at all, or may respond too late, incorrectly or without justification due to system limitations. There is a risk of accident or material damage. Observe the information on the system limits and intervene actively if necessary.

No parking assistance

Park Assist does not provide assistance in the following situations:

- ▷ On sharp bends.
- ▷ When towing a trailer.

Functional limitations

The system may have limited functionality in the following situations, for example:

- ▷ On uneven road surfaces, for example gravel roads.
- ▷ On slippery surfaces.
- ▷ On steep upward or downward gradients.
- ▷ If leaves have collected or snow has drifted or been piled up in the parking space.
- ▷ If the spare wheel has been fitted.
- ▷ If there are ditches or sudden drops, for example a quayside.

Limits of ultrasound measurement

The physical limits of ultrasound measurement may be reached when detecting objects in situations including the following:

- ▷ Small children and animals.
- ▷ Persons wearing certain types of clothing, for example a coat.
- ▷ External interference with the ultrasound, for example by passing vehicles or loud machines.
- ▷ Sensors which are dirty, iced up, damaged or incorrectly adjusted.
- ▷ Certain weather conditions, for example high humidity, wet conditions, snowfall, extreme heat or strong wind.
- ▷ Trailer drawbars and tow hitches of other vehicles.
- ▷ Thin or wedge-shaped objects.
- ▷ Moving objects.
- ▷ Higher protruding objects, for example projecting walls or loads.
- ▷ Objects with corners and sharp edges.
- ▷ Objects with fine surfaces or structures, for example fences.
- ▷ Objects with porous surfaces.
- ▷ When a projecting load is being transported.

- ▶ Low objects already indicated, for example kerbs, may enter the sensors' blind areas before or after a continuous tone is given.
- ▶ In some cases, parking spaces may be detected that are not suitable or suitable parking spaces may not be detected.

Tyre size

The park position may vary, depending on the tyre size.

Malfunction

A Check Control message is shown.

Park Assist has failed. Have the system checked by a Service Partner of the manufacturer or another qualified Service Partner or a specialist workshop.

Air conditioning

Vehicle equipment

This chapter describes all standard, country-specific and optional equipment available for the model series. It may therefore describe equipment and functions which are not installed in your vehicle, for example on account of the optional equipment selected or the national-market version. This also applies to safety-relevant functions and systems. Please comply with the relevant laws and regulations when using the corresponding functions and systems.

- ▷ Emissions-tested interior.
- ▷ Microfilter.
- ▷ Climate control system for regulating temperature, air flow and recirculated air mode.

Depending on the equipment:

- ▷ Microfilter/active carbon filter.
- ▷ Automatic air recirculation control AUC.
- ▷ Independent ventilation.

Interior air quality

The air quality in the vehicle is improved by the following components:

Air conditioning system

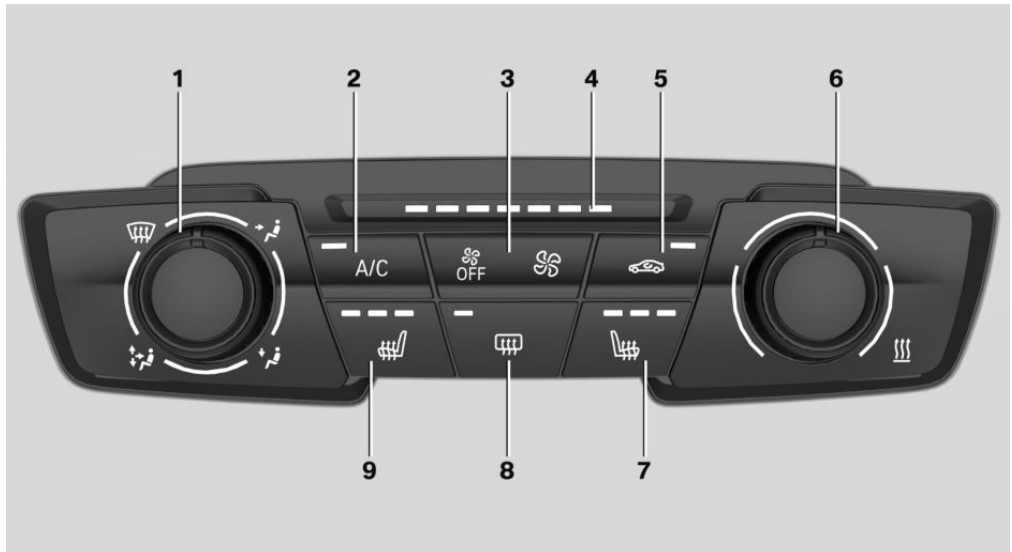

1 Air distribution

2 Cooling function

- 3 Air flow
- 4 Air flow display
- 5 Recirculated-air mode
- 6 Temperature

- 7 Seat heating, right 87
- 8 Rear window heating
- 9 Seat heating, left 87

Air conditioning functions in detail

Switching the system on/off

Switching on

Press any button, with the following exceptions:

- ▷ Rear window heating.
- ▷ Seat heating.

Switching off



Hold down left button until the control shuts down.

Temperature

Principle

The system heats or cools, depending on the set temperature.

Adjusting



Turn the wheel to select the desired temperature.

Avoid switching between different temperature settings in rapid succession. The automatic air conditioning may not have sufficient time to adjust to the set temperature.

Cooling function

Principle

The air in the interior is cooled and dried and then heated again depending on the temperature setting.

The interior can only be cooled when the engine is running.

Switching on/off



Press the button.

The LED is illuminated when the cooling function is switched on.

Depending on the weather conditions, the windshield and side windows may mist over for a short time when the engine is started.

Cooling produces condensation, see page 229, which then exits underneath the vehicle.

Recirculated-air mode

Principle

If the air outside the vehicle has an unpleasant odour or contains pollutants, the air supply to the interior of the vehicle can be shut off. The air inside the vehicle is then recirculated.

Operation



Press the button repeatedly to call up an operating mode:

- ▷ LED off: ambient air is constantly entering the car.
- ▷ LED on, recirculated-air mode: the air supply from outside is permanently shut off.

The recirculated-air mode automatically switches off after a given time depending on the ambient conditions, to avoid condensation.

Continuous use of recirculated-air mode worsens air quality inside the vehicle and increases condensation on the windows.

In the event of condensation, switch off recirculated-air mode and increase the air flow if necessary.

Air flow, manual

Principle

The air flow for air conditioning can be set manually.

Adjusting



Press left or right side of button: reduce or increase air flow.

The intensity is shown by the LEDs. The highest stage is seven illuminated LEDs.

The amount of air of the air conditioning is reduced as necessary to save the battery.

Adjusting the air distribution manually





Principle

The air distribution for air conditioning can be set manually.

Adjusting



Turn the wheel to select the desired program or the desired intermediate setting.

- ▷  Windows.
- ▷  Upper body area.
- ▷  Footwell.
- ▷  Windows, upper body area and footwell.

Defrosting windows and removing condensation

Perform the following settings to defrost the windows and remove condensation:

- ▷ Direct the air distribution onto the windows.
- ▷ Increase the air flow.
- ▷ Increase the temperature.
- ▷ Switch on the cooling function if needed.

Rear window heating



Press the button. The LED is illuminated.

The rear window heating is switched off automatically after a while.

Press and hold the button for more than 3 seconds for continuous activation. Press the button again to deactivate.

The rear window heating can only be activated continuously at an outside temperature below approximately 5 °C/41 °F.

Microfilter

In outside and recirculated-air mode, the microfilter filters dust and pollen from the air.

Have this filter replaced when the vehicle is serviced, see page [287](#).

Automatic air conditioning

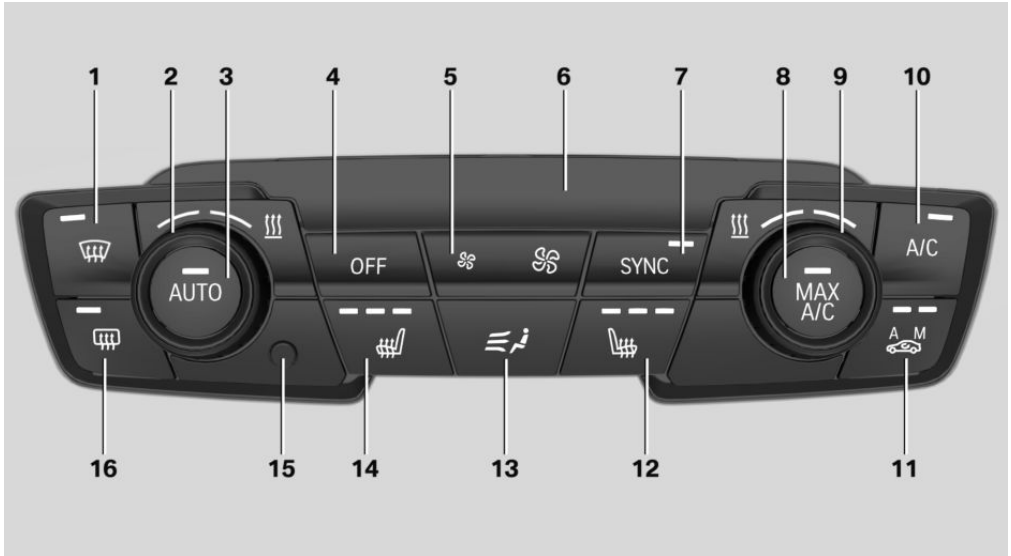

- | | |
|--|--|
| <p>1 To defrost windows and remove condensation</p> <p>2 Temperature, left</p> <p>3 AUTO program</p> <p>4 Switching the system off</p> <p>5 Air flow, AUTO intensity</p> <p>6 Display</p> <p>7 SYNC program</p> <p>8 Maximum cooling</p> | <p>9 Temperature, right</p> <p>10 Cooling function</p> <p>11 AUC/recirculated-air mode</p> <p>12 Seat heating, right 87</p> <p>13 Air distribution</p> <p>14 Seat heating, left 87</p> <p>15 Interior-temperature sensor</p> <p>16 Rear window heating</p> |
|--|--|

Air conditioning functions in detail

Switching the system on/off

Switching on

Press any button, with the following exceptions:

- ▷ SYNC program.
- ▷ Rear window heating.
- ▷ Seat heating.

Switching off

Press the button.

Temperature

Principle

The automatic air conditioning adjusts to the set temperature as quickly as possible, using maximum cooling or heating power if necessary. The temperature is then maintained.

Adjusting



Turn the wheel to select the desired temperature.

The selected temperature is shown on the display for the automatic air conditioning.

Avoid switching between different temperature settings in rapid succession. The automatic air conditioning may not have sufficient time to adjust to the set temperature.

Cooling function

Principle

The air in the interior is cooled and dried and then heated again depending on the temperature setting.

The interior can only be cooled when the engine is running.

Switching on/off



Press the button.

The LED is illuminated when the cooling function is switched on.

Depending on the weather conditions, the windscreen and side windows may mist over for a short time after the engine has been started.

The cooling function is switched on automatically in the AUTO program.

Cooling produces condensation, which then exits underneath the vehicle.

Maximum cooling

Principle

System is set to lowest temperature, optimum air flow and recirculated-air mode.

Operating requirements

The function is available above an outside temperature of approximately 0 °C/32 °F And with the engine running.

Switching on/off



Press the button.

The LED is illuminated when the system is switched on.

The air flows from the outlets for the upper body area. Therefore open the outlets.

The air flow can be adapted when the program is active.

AUTO program

Principle

The AUTO program cools, ventilates or heats the interior automatically.

The air flow, air distribution and temperature are regulated automatically depending on the interior temperature, the selected temperature setting and the selected intensity setting.

Switching on/off



Press the button.

The LED is illuminated when the AUTO program is switched on.

Depending on the selected settings and external influences, the air is directed towards the windscreen, the side windows, the upper body and into the footwell.

The cooling function, see page 205, is switched on automatically in the AUTO program.

Point the side nozzles at the side windows.

A fogging sensor also controls the program so that window condensation is avoided as much as possible.

Intensity

The intensity can be adjusted when the AUTO program is active. This changes the automatic control for the air flow.



Press left or right side of button: reduce or increase intensity.

The selected intensity is shown on the display for automatic air conditioning.

Automatic air recirculation control/air recirculation function

Principle

Automatic air recirculation control detects pollutants in the outside air. The supply of outside air is shut off and the interior air is recirculated.

General

When the system is activated, a sensor detects pollutants in the outside air and automatically controls the closing off of the incoming air supply.

When the system is deactivated, outside air flows into the interior continuously.

Continuous use of recirculated-air mode worsens air quality inside the vehicle and increases condensation on the windows.

Switching on/off



Press the button repeatedly to call up an operating mode:

- ▷ LEDs off: ambient air flows continuously into the car.
- ▷ Left-hand LED on, automatic air recirculation control AUC mode: a sensor detects pollutants in the fresh air and shuts off the supply automatically.
- ▷ Right-hand LED on, recirculated-air mode: the air supply from outside is permanently shut off.

The recirculated-air mode automatically switches off at low outside temperatures after a given time, to avoid condensation.

If there is condensation on the window, switch off recirculated-air mode and press the AUTO button to use the condensation sensor. Ensure that air can flow towards the windscreen.

Air flow, manual

Principle

The air flow for air conditioning can be set manually.

General

To be able to adjust the air flow manually, first switch off the AUTO program.

Adjusting



Press left or right side of button: reduce or increase air flow.

The selected air flow is shown on the display for automatic air conditioning.

In order to protect the battery the air flow rate is reduced, if necessary.

Adjusting the air distribution manually

Principle

The air distribution for air conditioning can be set manually.

Adjusting



Press the button repeatedly to select a program:

- ▷ Upper body area and footwell.
- ▷ Footwell.
- ▷ Windows and footwell.
- ▷ Windows.
- ▷ Windows and upper body area.

- ▷ Upper body area.
- ▷ Windows, upper body area and footwell.

If there is condensation on the window, press the AUTO button in order to use the advantages of the condensation sensor.

SYNC program

Principle

The system enables the current temperature setting on the driver's side to be transferred to the front passenger's side.

Switching on/off



Press the button.

The current temperature setting on the driver's side is transferred to the front passenger's side.

The program is switched off if the setting is changed on the front passenger side.

Defrosting windows and removing condensation

Principle

Ice and condensation are quickly removed from the windscreen and the front side windows.

Switching on/off



Press the button.

The LED is illuminated when the system is switched on.

The air flow can be adapted when the program is active.

If there is condensation on the window, switch on the cooling function as well or press the AUTO button to use the condensation sensor.

Rear window heating



Press the button. The LED is illuminated.

The rear window heating is switched off automatically after a while.

Press and hold the button for more than 3 seconds for continuous activation. Press the button again to deactivate.

The rear window heating can only be activated continuously at an outside temperature below approximately 5 °C/41 °F.

Microfilter/active carbon filter

In outside and recirculated-air mode, the microfilter/activated carbon filter filters dust, pollen and harmful gases from the air.

Have this filter replaced when the vehicle is serviced, see page 287.

Ventilation

Ventilation at front

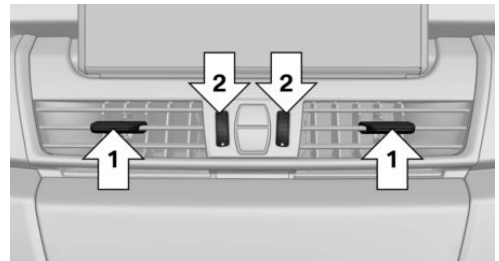

- ▷ Lever for changing the air flow direction, arrows 1.
- ▷ Knurled wheels to open and close the outlets steplessly, arrow 2.

Adjusting

- ▷ Ventilation for cooling:
Adjust the outlets so that air is directed towards you, for example if the vehicle's interior has become hot.
- ▷ Draught-free ventilation:
Adjust the outlets so that the air flows past you.

Ventilation in rear passenger compartment

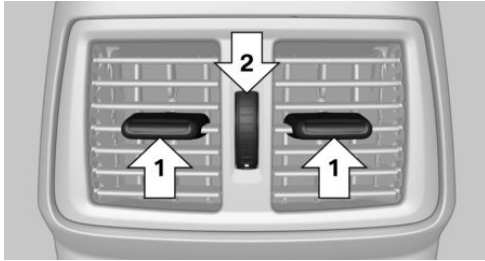

- ▷ Lever for changing the air flow direction, arrows 1.
- ▷ Knurled wheel for steplessly opening and closing the outlets, arrow 2.

to protect the battery. After the engine is started or after driving a short distance, the system will be available again.

- ▷ Ensure that the date and time are set correctly in the vehicle.
- ▷ Open the ventilation outlets to allow the air to enter the passenger compartment.

Switching on/off directly

Via iDrive:

1. "My Vehicle"
2. "Vehicle settings"
3. If necessary, "Climate comfort"
4. "Activate auxiliary ventilation now"

⚡ symbol on automatic air conditioning flashes when system is switched on.

Independent ventilation

Principle

The independent ventilation system ventilates the passenger compartment and lowers its temperature where required.

General

The independent ventilation can be switched on and off via two preselected switch-on times or directly. The system remains switched on for 30 minutes.

The independent ventilation is operated using iDrive.

Operating requirements

- ▷ Direct operation: vehicle is in radio-ready state.
- ▷ Direct operation or preselected switch-on time: does not depend on the outside temperature.
- ▷ Battery must be sufficiently charged.

When activated, the independent ventilation uses power from the vehicle battery. As a result, the maximum operating time is restricted

Preselecting the switch-on time

Via iDrive:

1. "My Vehicle"
2. "Vehicle settings"
3. If necessary, "Climate comfort"
4. "Auxiliary ventilation"
5. Select the required switch-on time.
6. Set desired time.

Activating the switch-on time

Via iDrive:

1. "My Vehicle"
2. "Vehicle settings"
3. If necessary, "Climate comfort"
4. "For start time at:"

Activate the required switch-on time.

⚡ The symbol on the automatic air conditioning system is illuminated when the switch-on time is active.

⚡ The symbol on the automatic air conditioning system flashes when the system has cut in.

The system only switches on at the preselected time within the next 24-hour period. Afterwards, it must be reactivated.

Interior equipment

Vehicle equipment

This chapter describes all standard, country-specific and optional equipment available for the model series. It may therefore describe equipment and functions which are not installed in your vehicle, for example on account of the optional equipment selected or the national-market version. This also applies to safety-relevant functions and systems. Please comply with the relevant laws and regulations when using the corresponding functions and systems.

Sun visor

Glare protection

Fold the sun visor downwards or upwards.

Vanity mirror

A vanity mirror is located behind a cover in the sun visor. The mirror light switches on when the cover is opened.

Ashtray/lighter

Ashtray

Opening

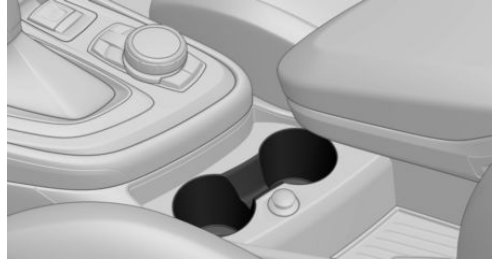

The ashtray can be inserted into the cup holder.

Emptying

Lift out the insert.

Lighter

⚠ WARNING

Contact with the hot heating element or the hot socket of the lighter can cause burns. Flammable materials can catch fire if the lighter is dropped or is held against objects. There is a risk of fire and danger of injury. There is a risk of material damage. Hold lighter by its handle. Ensure that children do not use the lighter.

⚠ NOTE

If metallic objects fall into the socket, they can cause a short circuit. There is a risk of material damage. After using the socket, re-fit the lighter or socket cover.



The cigarette lighter is located in the centre console.



Press in the lighter.

The lighter can be removed when it pops back out.

Sockets

General

The cigarette lighter socket can be used as a socket for electrical devices when the engine is running or the ignition is switched on.

The total load of all sockets must not exceed 140 watts at 12 volts.

To avoid damage to the socket, do not insert an incompatible plug.

Safety notes

⚠ WARNING

Devices and cables, for example portable navigation devices, that are located in the deployment range of the airbags may impede airbag deployment or be thrown around the vehicle interior when the airbag is deployed. There is a danger of injury. Make sure that devices and cables are not in the deployment range of the airbags.

⚠ NOTE

Battery chargers for the vehicle battery may operate with high voltages and high currents which can overload or damage the 12-volt on-board network. There is a risk of material damage. Only connect battery chargers for the vehicle battery to the starting aid terminals in the engine compartment.

⚠ NOTE

If metallic objects fall into the socket, they can cause a short circuit. There is a risk of material damage. After using the socket, re-fit the lighter or socket cover.

Front centre console



Remove the cover or lighter.

In front seat passenger compartment



Socket is located under the glove compartment.

Inside the luggage compartment

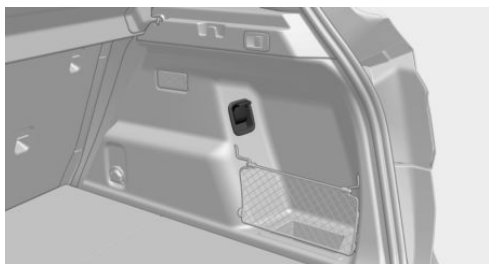

The socket is on the right in the luggage compartment.

USB port

Principle

Mobile devices with a USB port can be connected to the USB port.

General

Please comply with the notes on connecting mobile devices to the USB port in the chapter on USB connections, see page 55.

Front USB port

In the centre console

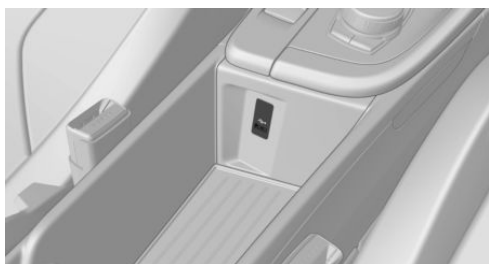

The USB port is located in the centre console.

Properties without wireless charging:

- ▷ USB port type A.

- ▷ For charging mobile devices and transferring data.
- ▷ Charge current: max. 1.5 A.

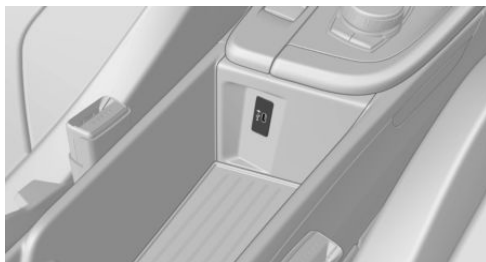

The USB port is located in the centre console.

Properties with wireless charging:

- ▷ USB port type C.
- ▷ For charging mobile devices and transferring data.
- ▷ Charge current: max. 3 A.

In the front centre console



The USB port is located in the front centre console.

Properties with wireless charging:

- ▷ USB port type A.
- ▷ For charging mobile devices and transferring data.
- ▷ Charge current: max. 1.5 A.

In the rear centre console



There are two USB ports in the rear centre console.

Properties:

- ▷ USB port type C.
- ▷ For charging mobile devices.
- ▷ Charge current: max. 3 A per port.

Connecting an external device

When connecting, bear the following in mind:

- ▷ Do not use force when inserting the connector into the USB port.
- ▷ Use a flexible adapter cable.
- ▷ Protect the USB device from mechanical damage.
- ▷ Due to the large variety of USB devices available on the market, it is not possible to guarantee that every device can be operated via the vehicle.
- ▷ Do not expose the USB devices to extreme environmental conditions, for example very high temperatures; see the operating instructions of the device.
- ▷ Due to the large variety of different compression techniques, correct playback of the media stored on the USB device cannot be guaranteed in every case.
- ▷ A connected USB device is charged via the USB port if the device supports this. At higher temperatures, the USB device may reduce the charge current.

- ▷ To ensure correct transmission of the stored data, do not charge a USB device from the 12 V power socket in the vehicle when the device is also connected to the USB port.
- ▷ Depending on how the USB device is being used, settings may need to be performed on the USB device; see the operating instructions of the device.

Incompatible USB devices:

- ▷ USB hard drives.
- ▷ USB hubs.
- ▷ USB memory card reader with several slots.
- ▷ HFS-formatted USB devices.
- ▷ Devices such as fans or lamps.

Wireless charging dock

Principle

The wireless charging dock permits the following functions to be performed wirelessly:

- ▷ Charging of Qi-compatible mobile phones or other mobile devices which support the Qi standard.
- ▷ Connection of the mobile telephone to the external aerial.

This ensures better network reception and consistent playback quality, depending on the country.

General

When inserting the mobile telephone, make sure there are no objects between it and the wireless charging dock.

During charging, the surface of the dock and the mobile telephone can become hot. At higher temperatures, the charge current through the mobile telephone may be reduced; in exceptional cases, the charging process is temporarily interrupted. Observe the relevant information in the operating instructions for the mobile telephone.

Safety notes

WARNING

When charging a Qi-compatible device in the wireless charging dock, any metal objects located between the device and the dock can become very hot. If storage media or electronic cards, for example smart cards, cards with magnetic strips or cards for transmitting signals, are placed between the device and the dock, card function may be impaired. There is a risk of injury and material damage. When charging mobile devices, make sure there are no objects between the device and the dock.

NOTE

The dock is designed for mobile telephones up to a certain size. Using excessive force to insert a mobile telephone may damage the dock or the mobile telephone. There is a risk of material damage. Observe the maximum dimensions for the mobile telephone. Do not force the mobile telephone into the dock.

Overview

Tray in the centre console:

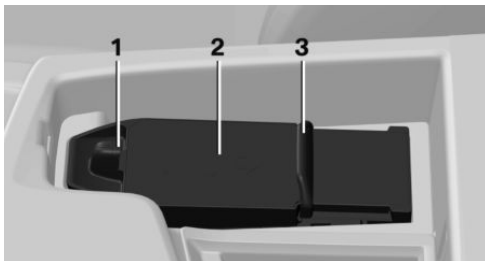

- 1 Front holder with LED
- 2 Storage area
- 3 Adjustable holding clip

Operating requirements

- ▷ The mobile telephone must support and be compatible with the required Qi standard.
If the mobile telephone does not support the Qi standard, the mobile telephone can be charged using a special Qi-compatible charging pad.
- ▷ The ignition is switched on.
- ▷ Note the maximum dimensions of the mobile telephone.
- ▷ Only use protective sleeves and covers up to a maximum thickness of 2 mm, 0.07 in. Otherwise, the charging function may be impaired.
- ▷ The mobile telephone to be charged is located in the middle of the dock.

Operation

Inserting the mobile telephone

The maximum size for a mobile phone is approximately 150 x 78 x 16 mm, 5.9 x 3.07 x 0.62 in.

1. Open the centre armrest.
2. Slide the holding clip backwards.
3. Insert the mobile telephone with the display upwards in the direction of the front holder, arrow 1.

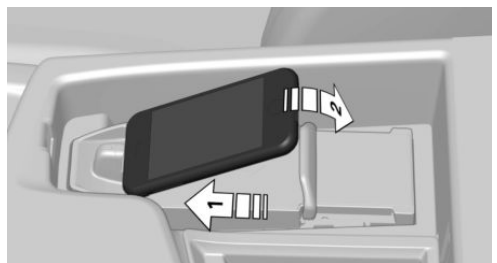

4. Place the mobile telephone in the dock area, arrow 2.
5. Push the holding clip forwards and clip the mobile telephone in the dock.
6. Close the centre armrest.

Removing the mobile telephone

1. Open the centre armrest.
2. Slide the holding clip backwards and remove the mobile telephone.

LED displays

Colour	Meaning
Blue	The mobile telephone is charging. Depending on the model and vehicle, the blue LED extinguishes once the inserted Qi-compatible mobile telephone is fully charged.
Orange	The mobile telephone is not charging. The mobile phone may be exposed to excessively high temperatures or there may be foreign bodies in the charging dock.
Red	The mobile telephone is not charging. Contact a Service Partner of the manufacturer or another qualified Service Partner or a specialist workshop.

System limits

If the mobile phone or the vehicle interior is exposed to excessively high temperatures, the charging functions of the mobile telephone might be restricted and functions might no longer work.

Folding tray tables, rear

General

Each front-seat backrest incorporates a fold-down table.

Fold away the fold-down tables again after use.

The maximum load on fold-down tables is 6 kg / 13 lb. If overloaded, the fold-down tables drop down to avoid damage.

Safety notes

⚠ WARNING

Parts of the body can be trapped when folding up and down and adjusting the height of the fold-down table. There is a danger of injury. When folding up and down and adjusting, make sure that the area of movement of the fold-down table is kept clear.

⚠ WARNING

When folded down, the table protrudes into the vehicle interior and can lead to injuries in the event of an accident, braking or evasive action. Objects on the table may be flung into the interior during the journey. There is a danger of injury. Do not fold down or use fold-down tables during the journey.

⚠ WARNING

Adjusting the fold-down table can result in objects falling down, and the table can be pushed out of the rail. There is a risk of injury or material damage. When adjusting, remove all objects such as beverages from the fold-down table and do not push the fold-down table beyond the point of resistance when adjusting.

Folding out

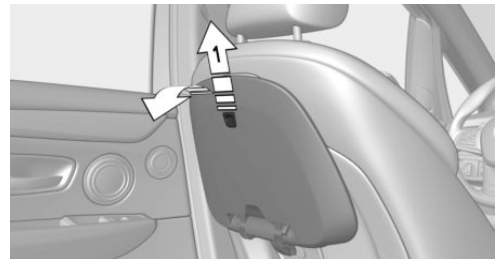

Pull the lever, arrow 1, and adjust to the desired angle.

To adjust the angle

The fold-down table can be adjusted to the angle of the front seat backrests.

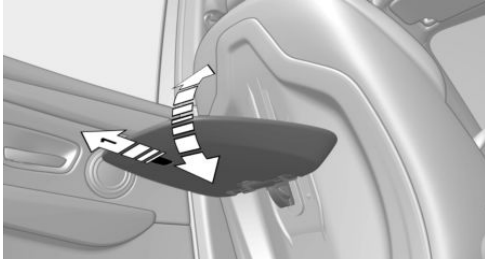

Pull the lever into the direction of the table edge, arrow 1, and adjust to the desired angle.

Adjusting the height

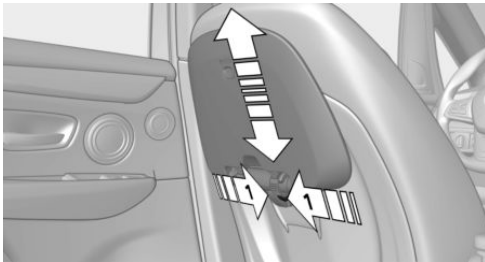

Push buttons on both sides, arrow 1, and set the required height.

Folding in

1. Press the buttons on both sides and push the fold-down table into the lowest position until it engages.
2. Pull the lever towards the edge of the table and fold the fold-down table up.

Removing

The fold-down table can be removed for cleaning.

1. Press the buttons on both sides and push the fold-down table up beyond the point of resistance.

2. Remove the fold-down table.

Luggage compartment

Luggage compartment cover

General

The luggage compartment cover is raised when the tailgate is opened.

Safety note

⚠ WARNING

Loose objects or devices connected by a cable to the vehicle, for example mobile telephones, may be thrown around the interior during the journey, for example in the event of an accident or when braking or taking evasive action. There is a danger of injury. Ensure that loose objects or devices connected by cable to the vehicle are secured in place in the interior.

Removing

The cover can be removed for stowing bulky items.

1. Unhook the retaining straps on the tailgate.
2. Lift the cover and remove towards the rear.

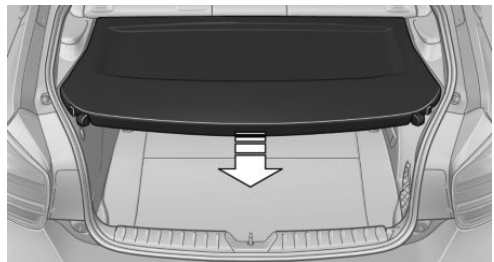

Inserting

1. Insert the cover into the holders.
2. Attach the retaining straps.

Enlarging the luggage compartment

Principle

Depending on the equipment fitted, the luggage compartment can be enlarged as follows:

- ▶ The rear seat backrests can be folded down.
- ▶ The rear seat backrests can be placed in the cargo position to achieve an upright loading position.
- ▶ The front passenger seat backrest can be folded down.

General

The rear seat backrest is split 40–20–40. The outer rear seat backrests can be folded down individually or the middle part separately.

Depending on the equipment fitted, the rear seat backrests can be folded down from the rear or from the luggage compartment.

Safety notes

WARNING

Risk of entrapment when folding down the rear seat backrest. There is a risk of injury or material damage. Before folding down, make sure that the area of movement of the rear seat backrest and the head restraint is kept clear.

WARNING

If a rear seat backrest is not locked, unsecured cargo may be flung into the interior, for example in the event of an accident or when braking or taking evasive action. There is a danger of injury. Make sure that the rear seat backrest is locked after it has been folded back.

WARNING

The rear seat backrests may move unexpectedly during a journey if they are unintentionally released via the loops. There is a danger of injury. Use the loops solely for releasing the rear seat backrests. Do not attach objects to the loops.

WARNING

If the rear seat backrest is not locked, the protective effect of the middle seat belt is not ensured. There is a risk of injury or even death. Lock the wider rear seat backrest when using the middle seat belt.

WARNING

If the seat is not adjusted properly or the child seat has been installed incorrectly, the child restraint system may have limited stability or may not be stable at all. There is a risk of injury or even death. Make sure that the child restraint system rests firmly against the backrest. Wherever possible, adapt the backrest angle of all the relevant seat backrests and adjust the seats correctly. Make sure that the seats and their backrests are correctly engaged or locked. If possible, adjust the height of the head restraints, or remove them.

NOTE

Vehicle parts can be damaged when folding down the rear seat backrest. There is a risk of material damage. When folding down, make sure that the area of movement of the rear seat backrest including head restraint is kept clear.

Folding the rear seat backrest down from the rear

1. Pull the loop to unlock the rear seat backrest.

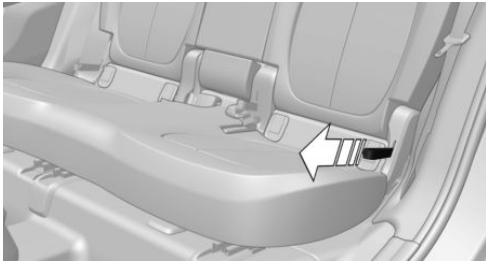

2. The rear seat backrest folds forwards.

Cargo position

Principle

The rear seat backrests can be individually moved to an upright loading position. They can be adjusted to various inclination settings as required.

Adjusting

1. Pull the loop.

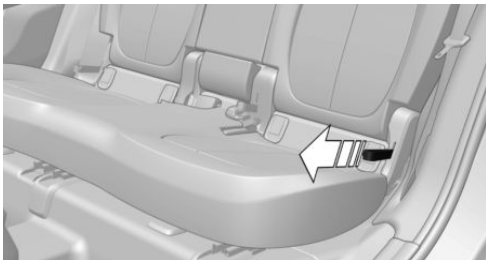

2. Set the loading position of the rear seat backrest as required.
3. Lock the rear seat backrest in place.

Folding back the rear seat backrest

Without cargo position:

1. Pull the loop.

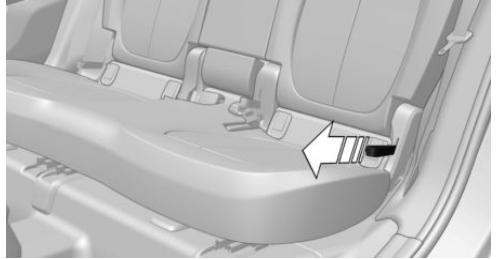

2. Fold the rear seat backrest back into seat position and engage.

With cargo position:

1. Pull the loop.

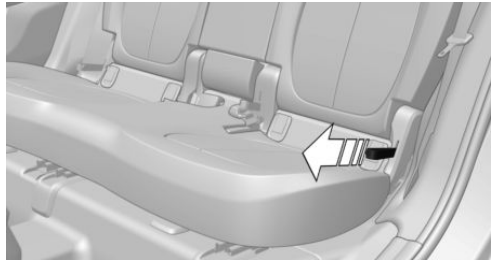

2. Fold the rear seat backrest back. The rear seat backrest initially engages in the loading position.
3. Pull loop once again.
4. Fold the rear seat backrest back into seat position and engage.

Folding down the front passenger seat backrest

WARNING

If the backrest of the front passenger seat is folded down, the protective effect for the rear seats is lost in the event of an accident. There is a danger of injury. Do not occupy the seat behind the front passenger seat and the middle rear seat during the journey if the backrest of the front passenger seat is folded down.

NOTE

If the backrest of the front passenger seat is folded forward, the seat can be damaged by the front passenger airbag in the event of an accident. There is a risk of material damage. Deactivate the front passenger airbag if the backrest of the front passenger seat is folded forward.

Deactivate the front passenger airbag, see page 154.



Pull the lever. The backrest folds forward.

Luggage compartment separating net

Luggage net, large

Install the large luggage compartment separating net behind the front seats with the rear seat backrest folded down.

1. Fold down rear backrests, see page 217.
2. Fold up cover caps up on the roof frame until they engage.

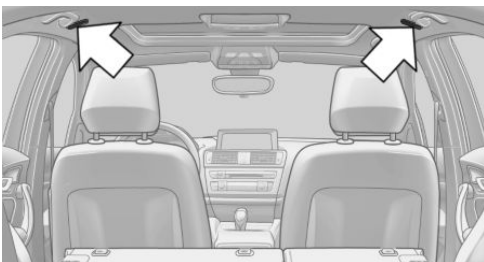

3. Insert both upper fastening pins of the luggage compartment separating net into the holders as far as they will go, arrow 1, and push forwards.

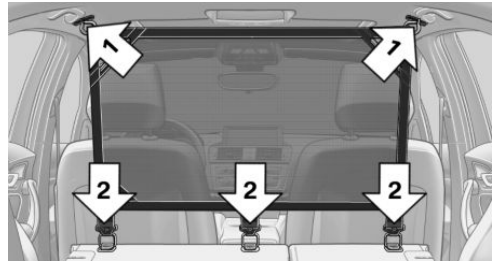

4. Attach the luggage compartment separating net with the three lower hooks into the three eyes on the folded rear seat backrest, arrows 2, raise the rear seat backrests a little to do this.

Make sure that the lower hooks are hooked into the eyes from behind.



Luggage compartment separating net, small

Install the small luggage compartment separating net behind the second seat row with the rear seat backrest in upright position.

1. Remove the luggage compartment cover.
2. Insert both upper fastening pins of the luggage compartment separating net into the

holders as far as they will go, arrow 1, and push forwards.

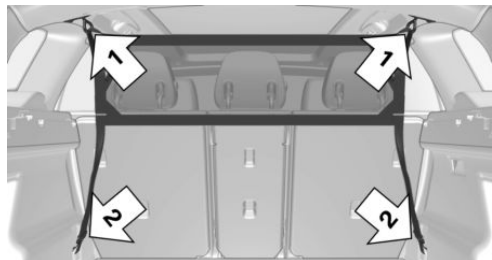

3. Hook the luggage compartment separating net with the hooks to the upper lashing eyes in the luggage compartment, arrows 2.

Ski and snowboard bag

The ski and snowboard bag is located in a protective sleeve in the luggage compartment.

Follow the installation and operating instructions enclosed in the protective sleeve.

Storage compartments

Vehicle equipment

This chapter describes all standard, country-specific and optional equipment available for the model series. It may therefore describe equipment and functions which are not installed in your vehicle, for example on account of the optional equipment selected or the national-market version. This also applies to safety-relevant functions and systems. Please comply with the relevant laws and regulations when using the corresponding functions and systems.

Safety notes

WARNING

Loose objects or devices connected by a cable to the vehicle, for example mobile telephones, may be thrown around the interior during the journey, for example in the event of an accident or when braking or taking evasive action. There is a danger of injury. Ensure that loose objects or devices connected by cable to the vehicle are secured in place in the interior.

NOTE

Anti-slip mats can damage the instrument panel. There is a risk of material damage. Do not use anti-slip mats.

Storage facilities in the interior

The following storage facilities are located in the interior:

- ▷ Storage compartment in front centre console, see page 221.
- ▷ Large storage compartment in centre console, see page 222.
- ▷ Glove compartment on the passenger side, see page 222.
- ▷ Glove compartment on the driver's side, see page 222.
- ▷ Compartments in the doors, see page 223.
- ▷ Storage compartment in the centre armrest, see page 223.
- ▷ Cup holders, see page 223.
- ▷ Storage compartment in the centre console in the rear, see page 223.
- ▷ Coat hooks, see page 224.
- ▷ Storage compartments in the luggage compartment, see page 225.
- ▷ Further storage compartments in the interior, see page 224.

Storage compartment in front centre console

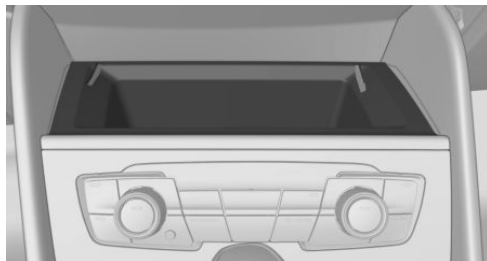

There is a storage compartment in the front of the centre console.

Large storage compartment in centre console

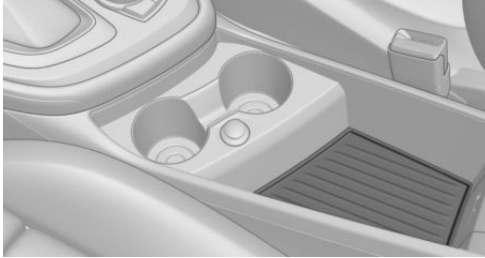

There is a large storage compartment in the centre console between the front seats.

Glove compartment

Front passenger's side

Safety note

WARNING

The glove compartment protrudes into the interior when it is open. Objects in the glove compartment may be thrown around the interior during the journey, for example in the event of an accident or when braking or taking evasive action. There is a danger of injury. Immediately close the glove compartment after using it.

Opening



Pull the handle.

The lighting in the glove compartment comes on.

Closing

Shut the lid.

Driver's side

Safety note

WARNING

The glove compartment protrudes into the interior when it is open. Objects in the glove compartment may be thrown around the interior during the journey, for example in the event of an accident or when braking or taking evasive action. There is a danger of injury. Immediately close the glove compartment after using it.

Opening

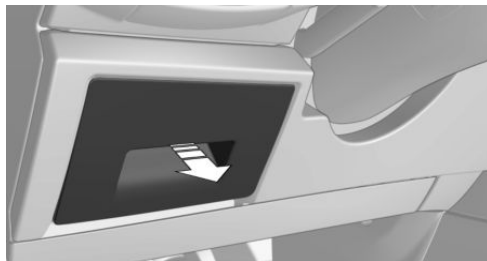

Pull the handle.

Closing

Shut the lid.

Pockets in the doors

General

There are storage compartments in the doors.

Safety note

WARNING

Breakable objects, for example glass bottles or glasses, may get broken in the event of an accident or when braking or taking evasive action. Splinters may scatter throughout the interior. There is a risk of injury or material damage. Do not use breakable objects during a journey. Only stow breakable objects in closed storage compartments.

Centre armrest

Front

There is a storage compartment in the centre armrest between the front seats.

Opening



Pull the lever, arrow 1, and fold the centre armrest upwards, arrow 2.

Adjusting

The centre armrest can be adjusted to several different angles.

Storage compartment in centre console in rear

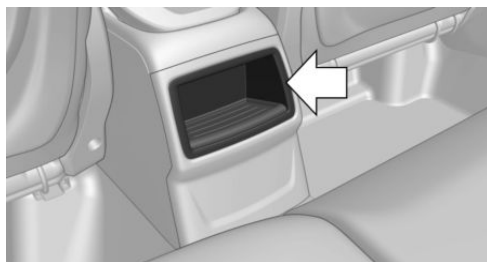

There is a storage compartment in the centre console in the rear.

Cup holders

Safety note

WARNING

Unsuitable containers placed in the cup holders may damage the cup holders or be flung into the interior, for example in the event of an accident or when braking or taking evasive action.

Spilt liquids can distract the driver from the road and lead to an accident. Hot beverages may damage the cup holders or cause scalding. There is a risk of injury or material damage. Do not force objects into the cup holder. Use lightweight, sealable and shatterproof containers. Do not transport hot drinks.

Front



Rear

NOTE

If the cup holder is open, the centre armrest cannot be folded back. There is a risk of material damage. Push back the covers before folding up the centre armrest.

In the centre armrest.

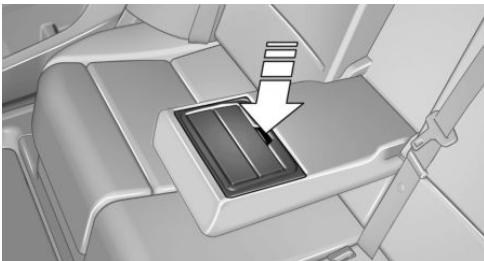

Pull the centre armrest forward by the loop.

To open: press the button.

To close: push both covers back in one after the other.

Further storage compartments in the interior

Nets on the backrests of the front seats

Small objects can be stowed in the nets on the backrests.

Coat hooks

General

The coat hooks are located on the grab handles in the rear.

Safety notes

WARNING

Items of clothing on the coat hooks can impair visibility when driving. There is a risk of accident. Hang items of clothing from the coat hooks in such a way that they do not obstruct visibility when driving.

WARNING

Incorrect use of the coat hooks can present a danger, for example if objects are thrown around as a result of braking or evasive action. There is a risk of injury and material damage. Only hang lightweight objects, for example items of clothing, on the coat hooks.

Storage compartments in the luggage compartment

Side storage compartment right

There is a storage compartment on the right side.

Net for storage compartment

Smaller items can be stowed in the net of the right storage compartment.

Multifunction hooks

WARNING

Incorrect use of the multifunction hooks may present a danger, for example if objects are flung around in the event of braking and evasive action. There is a risk of injury and material damage. Only hang lightweight objects, for example shopping bags, on the multifunction hooks. Only transport heavy luggage in the luggage compartment if suitably secured.

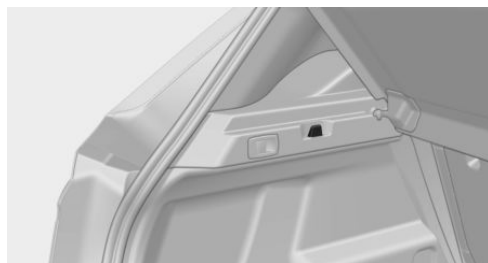

There is a multifunction hook on each side of the luggage compartment.

Tensioning strap

There is a tensioning strap on the left-hand trim panel for securing small objects.

Lashing eyes in the luggage compartment

There are lashing eyes in the luggage compartment for securing the loads, see page 232.

Storage space under luggage compartment floor

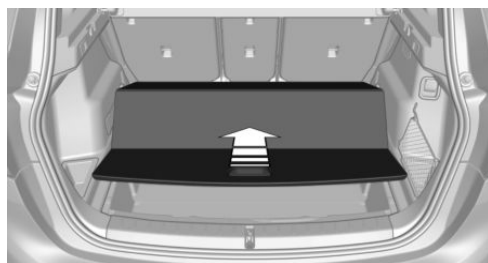

The luggage compartment floor can be folded. To open, lift luggage compartment floor slightly and push forwards.

Driving precautions

Vehicle equipment

This chapter describes all standard, country-specific and optional equipment available for the model series. It may therefore describe equipment and functions which are not installed in your vehicle, for example on account of the optional equipment selected or the national-market version. This also applies to safety-relevant functions and systems. Please comply with the relevant laws and regulations when using the corresponding functions and systems.

Running in

General

Moving parts need to adjust to each other.

The following notes will help to maximise the vehicle's lifetime and efficiency.

Do not use Launch Control when running in.

Safety note

WARNING

New parts and components can cause safety and driver assistance systems to respond with a delay. There is a risk of accident. After new parts have been installed or if the vehicle is new, drive moderately and take action promptly if necessary. Please comply with running-in procedures for the corresponding parts and components.

Engine, gearbox and differential

Up to 2000 km, 1200 miles

Do not exceed the maximum engine revs and speed:

- ▷ With petrol engines, 4500 rpm and 160 km/h, 100 mph.
- ▷ With diesel engines, 3500 rpm and 150 km/h, 93 mph.

Generally avoid kick-down and driving under full load.

From 2000 km, 1200 miles onwards

Engine and road speeds can be gradually increased.

Tyres

Due to the manufacturing process, new tyres do not achieve their full road grip immediately.

Drive moderately for the first 300 km, 200 miles.

Brake system

Brake discs and pads only achieve their full effectiveness after approximately 500 km, 300 miles. Drive moderately during this running-in period.

Clutch

The clutch only begins to function optimally at approximately 500 km, 300 miles. Engage the clutch gently during this running-in period.

After fitting new parts

Please comply with the running-in procedures again if the components previously referred to are renewed.

General driving information

Closing the tailgate

Safety note

WARNING

When open, the tailgate protrudes above the vehicle and in the event of an accident, or when braking or taking evasive action, can endanger vehicle occupants and other road users or damage the vehicle. There is also a risk of exhaust fumes entering the interior of the vehicle. There is a risk of injury or material damage. Do not drive with the tailgate open.

Driving with the tailgate open

If there is no alternative to driving with the tailgate open:

- ▷ Close all the windows and the glass sunroof.
- ▷ Adjust the blower to a high setting.
- ▷ Maintain a moderate speed.

Hot exhaust system

WARNING

High temperatures may occur under the vehicle body during driving, for example because of the exhaust system. Contact with the exhaust system can lead to burns. There is a danger of injury. Do not touch the hot exhaust system, including the exhaust pipe.

WARNING

If flammable materials, for example leaves or grass, come into contact with hot parts of the exhaust system, these materials can catch fire. There is a risk of fire and danger of injury. Never remove the heat shields installed in this area or apply underbody protection to them.

Make sure that when driving, idling or parking, no flammable materials can come into contact with hot vehicle parts.

Exhaust gas particle filter

Principle

The exhaust gas particle filter collects soot particles. The soot particles are burned at high temperatures to clean the exhaust gas particle filter as necessary.

General

The cleaning process takes a few minutes, during which the following may occur:

- ▷ The engine may temporarily run a little roughly.
- ▷ A slightly higher engine speed may be required to achieve the usual power output.
- ▷ Fuel consumption may increase. The increased fuel consumption is shown as the mean value in the current consumption display.
- ▷ There may be a small amount of smoke from the exhaust, even after stopping the engine.
- ▷ Noise, for example from radiator fan operation, may be heard, even some minutes after stopping the engine.

It is normal for the radiator fan to keep running for several minutes, even after short trips.

Petrol engine: Cleaning the exhaust gas particle filter while driving

Various driver profiles ensure that the exhaust gas particle filter is self-cleaning. If, in addition to the self-cleaning function, the exhaust gas particle filter needs to be actively cleaned while driving, a Check Control message is displayed.

Proceed as follows the next time you drive outside of built-up areas for around 30 minutes:

- ▷ Deactivate cruise control systems.

- ▷ Take your foot off the accelerator repeatedly and allow the vehicle to roll in overrun mode, see page 246.
- ▷ If possible, drive at alternating speeds.

Peak power

Temporary peak power is delivered in relation to environmental factors. It may reach around 10 % above the rated power. The duration of the peak power increases as the ambient temperature rises.

- ▷ At 25 °C/77 °F, it lasts around 5 seconds.
- ▷ At -20 °C/-4 °F, it lasts around 40 seconds.

The information regarding peak power applies to 20i petrol engines.

Radio signals

WARNING

Certain vehicle functions may be affected by interference from high-frequency radio signals. Such signals are output from a series of transmission systems, for example from air traffic beacons or relay stations for mobile telecommunications.

We recommend you consult your Service Centre should you experience any difficulties.

Mobile communication in the vehicle

WARNING

There is a possibility of reciprocal interference between the vehicle electronics and mobile radio devices. Radiation is generated when mobile radio devices are transmitting. There is a risk of injury or material damage. If possible, only use mobile radio devices, for example mobile telephones, inside the vehicle if they are connected directly to an external aerial in order

to eliminate reciprocal interference and to divert the radiation away from the vehicle's interior.

Aquaplaning

On wet or slushy roads, a wedge of water can form between the tyres and the road.

This situation, known as aquaplaning, means that the tyre can actually lose contact completely with the road surface and the vehicle can neither be steered, nor the brakes properly applied.

Driving through water

General

Please comply with the following when driving through water:

- ▷ Deactivate the Automatic Start/Stop function.
- ▷ Only drive through still water.
- ▷ Drive through water only if it is not deeper than a maximum of 25 cm, 9.8 in.
- ▷ Drive through water at a walking speed of no more than 5 km/h, 3 mph.

Safety note

NOTE

Driving through excessively deep water too fast can cause water to enter the engine compartment, electrical system or transmission. There is a risk of material damage. When driving through water, do not exceed the maximum water depth and speed specified above.

Safe braking

General

The vehicle is equipped with an Anti-lock Brake System ABS as standard.

Perform full braking in situations that require it.

The vehicle remains steerable. Steer as smoothly as possible to avoid any obstacles.

A pulsing of the brake pedal and hydraulic regulating sounds indicate that the ABS is functioning.

Objects in the movement range of the pedals and in the footwell

WARNING

Objects in the driver's footwell can restrict the pedal travel or block a pedal that has been pressed. There is a risk of accident. Ensure that items in the vehicle are stowed securely and cannot get into the driver's footwell. Only use floor mats that are suitable for the vehicle and can be securely fastened to the floor. Do not use loose floor mats, and do not place several floor mats on top of one another. Make sure that there is sufficient space for the pedals. Ensure that floor mats are securely reattached after removal, for example for cleaning.

Wet roads

In wet weather, on gritted roads and in heavy rain, apply the brakes lightly every few kilometres/miles.

Ensure that you do not obstruct other road users when doing so.

The heat generated by braking dries the brake discs and brake pads and protects them against corrosion.

This helps to maintain the brake power so that it is available immediately when needed.

Downhill gradients

General

When driving on long or steep downhill stretches, use the gear in which the least braking is required. Otherwise the brake system can overheat and the braking effect is reduced.

Engine braking effect can be additionally increased by manually shifting down, even into first gear, if applicable.

Safety notes

WARNING

Even slight but continuous pressure on the brake pedal can cause overheating, brake pad wear or even brake system failure. There is a risk of accident. Avoid excessive loads on the brake.

WARNING

In neutral or when the engine is switched off, safety-relevant functions, for example engine braking effect or steering and braking force assistance, are either restricted or not available at all. There is a risk of accident. Do not drive in neutral or with the engine switched off.

Corrosion of the brake discs

Corrosion of the brake discs and contamination of the brake pads increase in the following circumstances:

- ▷ Low mileage.
- ▷ Extended periods when the vehicle is not used.
- ▷ Infrequent use of the brakes.
- ▷ Aggressive, acidic or alkaline cleaning agents.

During braking, corroded brake discs may cause brake judder which usually cannot be eliminated.

Condensation when vehicle is parked

When the automatic air conditioning is in operation, condensation develops and exits underneath the vehicle.

Driving on a racetrack

WARNING

The vehicle is not designed for use in motorsport competitions or similar. There is a risk of accident. Do not use the vehicle in motorsport competitions or similar.

The higher mechanical and thermal loads involved when driving on racetracks lead to increased wear. This wear is not covered by the warranty.

Before and after driving on a racetrack, have the vehicle checked at a Service Partner of the manufacturer or another qualified Service Partner or a specialist workshop.

Loads

Vehicle equipment

This chapter describes all standard, country-specific and optional equipment available for the model series. It may therefore describe equipment and functions which are not installed in your vehicle, for example on account of the optional equipment selected or the national-market version. This also applies to safety-relevant functions and systems. Please comply with the relevant laws and regulations when using the corresponding functions and systems.

Safety notes

WARNING

A high gross vehicle weight can make the tyres overheat, causing internal damage and a sudden loss of tyre inflation pressure. Handling characteristics may be adversely affected, for example reduced directional stability, longer stopping distance and altered steering characteristics. There is a risk of accident. Please comply with the permitted load index of the tyre, and do not exceed the permitted gross vehicle weight.

WARNING

If the permitted total weight and the permitted axle loads are exceeded, the operational safety of the vehicle is no longer guaranteed. There is a risk of accident. Do not exceed the permitted total weight and permitted axle loads.

WARNING

Loose objects or devices connected by a cable to the vehicle, for example mobile telephones, may be thrown around the interior during the journey, for example in the event of an accident or when braking or taking evasive action. There is a danger of injury. Ensure that loose objects or devices connected by cable to the vehicle are secured in place in the interior.

WARNING

The rear seat backrests may move unexpectedly during a journey if they are unintentionally released via the loops. There is a danger of injury. Use the loops solely for releasing the rear seat backrests. Do not attach objects to the loops.

WARNING

Incorrectly stowed objects may slip or be thrown into the interior, for example in the event of an accident or when braking or taking evasive action. Vehicle occupants could be struck and injured. There is a danger of injury. Stow and secure objects and the load correctly.

NOTE

The luggage compartment floor is designed for a specific maximum weight. Excessive weight or point loads can damage the luggage compartment floor. There is a risk of material damage. Do not exceed the maximum load of the luggage compartment floor, and distribute the load evenly over the luggage compartment floor.

The maximum load is 420 kg / 925 lb.

NOTE

Liquids in the luggage compartment may cause damage. There is a risk of material damage. Ensure that no liquids leak out into the luggage compartment.

Stowing and securing loads in the vehicle

- ▷ Wrap protective material around any sharp corners and edges on the load.
- ▷ Heavy loads: stow as far forward as possible, low down and directly behind the rear seat backrests.
- ▷ Very heavy loads: if there are no passengers on the rear seat, insert both outer seat belts into the respective opposite buckles.
- ▷ The luggage compartment, see page 216, can be enlarged to a transport large or bulky load.
- ▷ Do not stack load items above the upper edge of the backrests.
- ▷ Use the luggage compartment separating net, see page 219, to protect the vehicle's occupants. Make sure that objects cannot penetrate the luggage net.
- ▷ Smaller and light transported load: secure with tensioning straps or other suitable straps.
- ▷ Large and heavy loads: secure with lashing straps.

Lashing eyes in the luggage compartment

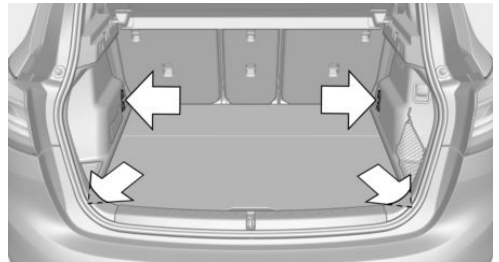

With luggage compartment separating net or ski and snowboard bag: six lashing eyes are located in the luggage compartment for securing the loads.

Load-securing equipment, for example lashing straps, tensioning straps or luggage compartment nets, must be secured to the lashing eyes in the luggage compartment.

Only use lower lashing eyes for securing the transported load with the luggage compartment separating net.

Roof rack

General

Installation is only possible with roof rails.

Roof racks are available as optional accessories.

Safety note

WARNING

When driving with a roof load, for example with a roof rack, the higher centre of gravity can mean that driving safety is no longer guaranteed in critical driving situations. There is a risk of accident or material damage. Do not deactivate Dynamic Stability Control DSC when driving with a roof load.

Fitting

Follow the installation instructions for the roof rack.

Loads

A loaded roof rack alters the vehicle's road behaviour and steering response by shifting its centre of gravity.

When loading and driving, bear the following in mind:

- Do not exceed the permitted roof and axle loads or the permitted gross weight.
- Make sure that there is sufficient space to raise and open the glass sunroof.
- Distribute the roof load evenly.
- The roof load must not be spread over a large area.
- Place heavy items of luggage at the bottom.
- Securely fasten the luggage, for example with tensioning straps.
- Do not allow objects to protrude into the swing range of the tailgate.
- Drive cautiously and avoid sudden acceleration, braking or cornering.

Rear luggage rack

Principle

The ball linkages of the rear luggage rack preparation or the trailer tow hitch can be used as a mount for rear luggage racks; for example, bicycle rack systems.

General

Rear luggage racks that have been classified as suitable by the vehicle manufacturer are available as special equipment.

Bicycle rack systems for up to three bicycles can be used.

Bracket for rear luggage rack

Safety notes

WARNING

Parts of the body can become trapped when inserting the ball linkage. There is a danger of injury. When inserting the ball linkage, make sure that the area of movement is kept clear.

WARNING

If the ball linkage is not locked, unstable driving conditions or accidents can result. There is a risk of accident or material damage. Before a journey with a trailer or load carrier, check that the ball linkage is correctly locked.

Storage

Store the ball linkage outside the vehicle – for example, on a rear-mounted rack – to reduce fuel consumption. If storing it inside the vehicle, stow the ball linkage securely, for example underneath the luggage compartment floor.

Ball linkage bracket

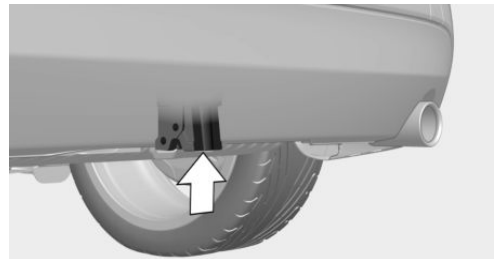

The bracket for the ball linkage is on the underside of the vehicle.

Follow the maintenance instructions, see page 312.

Overview

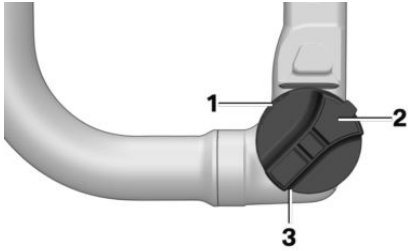

- 1 Lock display
- 2 Lock
- 3 Handwheel

Indicator on the ball linkage

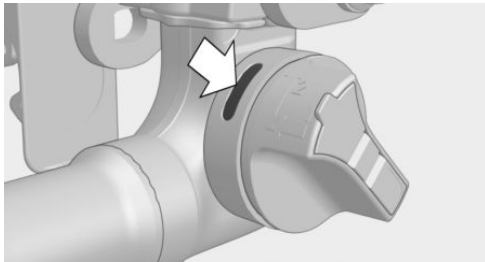

The colour of the indicator on the ball linkage shows the locking status.

Colour	Locking status
Red	Lock open, ball linkage can be inserted or removed.
Green	Lock closed, ball linkage is fitted firmly.
Orange	Lock closed, ball linkage is not fitted firmly.

Attaching ball linkage

Operating requirements

The ball linkage can be inserted if the following conditions are met:

- ▷ The lock is open.
- ▷ The indicator on the handwheel is red.

Opening the lock

Open the lock with the key supplied.

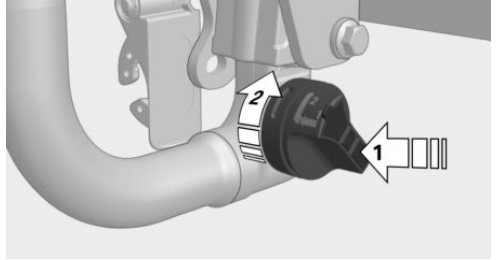

The lock is open if the handwheel can be pressed, arrow 1.

Pre-tensioning the handwheel

If the indicator is orange, pre-tension the handwheel:

1. Hold ball linkage firmly.
2. Press the handwheel, arrow 1, and turn in direction of the arrow as far as it will go, arrow 2.

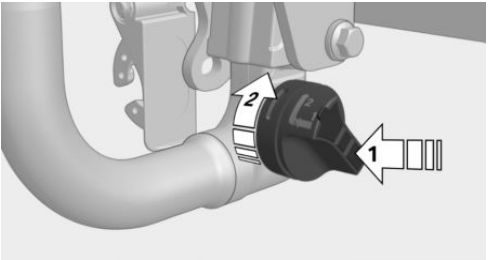

3. Handwheel engages.

Inserting ball linkage

1. Pull bracket cover downwards and store in the vehicle.

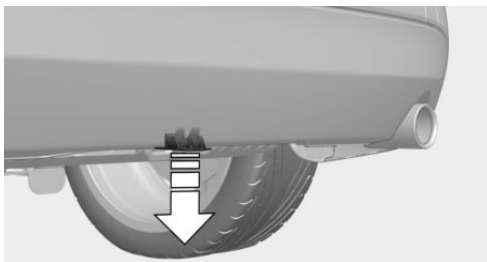

2. Insert the ball linkage from underneath into the bracket and push upwards, arrow 1.

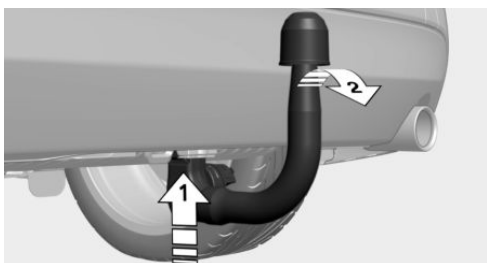

3. Pull the ball linkage backwards until it engages, arrow 2.

The ball linkage is inserted correctly if the indicator on the handwheel is green.

Locking the lock

The lock is used for preventing theft.

1. Insert the key into the lock.
2. Lock the lock in the handwheel.
3. Remove the key.

Checking the interlock

Ensure that the ball linkage is properly engaged by shaking it.

If the ball linkage is not fitted firmly, check the following points:

- ▶ The indicator on the handwheel is green.
- ▶ Ball linkage is lying flush in the bracket.

- ▶ The lock is locked and the key is removed.

If the indicator on the handwheel is not green, pre-tension the handwheel, see page 234.

If the ball linkage is not flush with the bracket, clean the bracket and the ball linkage, see page 312.

If the lock is locked, open it, see page 234.

Check with a Service Partner of the manufacturer or another qualified Service Partner or a specialist workshop if all points are met and the ball linkage is not firmly fitted.

Removing ball linkage

1. Fold up the lock cover.
2. Insert key and unlock the lock in the handwheel.
3. Remove the key.
4. Hold ball linkage firmly.
5. Press the handwheel, arrow 1, and turn in direction of arrow as far as it will go, arrow 2.

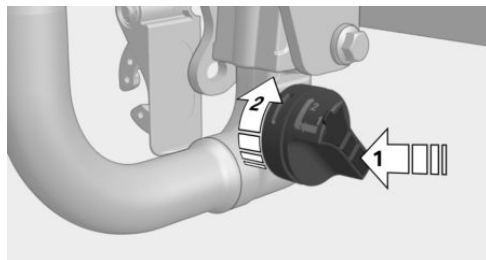

6. Pull the ball linkage out of the bracket.
7. Release the handwheel.
8. Insert cover in bracket.

Socket for rear luggage rack

General

The socket is underneath the bumper next to the bracket for the ball linkage.

Safety notes

WARNING

The socket for the trailer or rear luggage rack can heat up due to exhaust gases. There is a danger of injury. Allow the trailer socket to cool before swivelling out.

WARNING

The socket for the trailer or rear luggage rack is located near to protruding parts of the vehicle body. There is a danger of injury. Do not touch any parts of the body when swivelling the trailer socket in and out.

Swivelling in and out

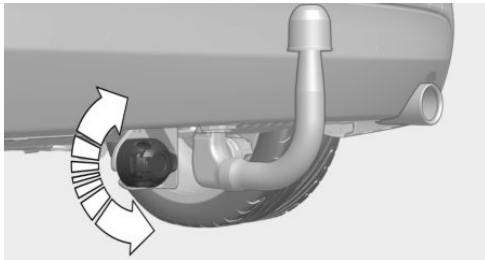

1. Grip the socket at the side.
2. Swivel the socket out or in up to the end position. To make it easier to swivel, pull the socket back slightly.

Fitting

Follow the installation instructions for the rear luggage rack.

Power consumption

Before beginning your journey, check the function of the trailer rear lights or the rear luggage rack lights.

Power of trailer rear lights or rear luggage rack lights must not exceed following values:

- ▶ Turn indicators: 42 watt per side.
- ▶ Tail lights: 50 watt per side.
- ▶ Brake lights: 84 watt total.
- ▶ Rear fog lights: 42 watt total.
- ▶ Reversing lights: 42 watt total.

To save vehicle battery power when the engine is off, keep the switch-on times of power consumers short.

Loads

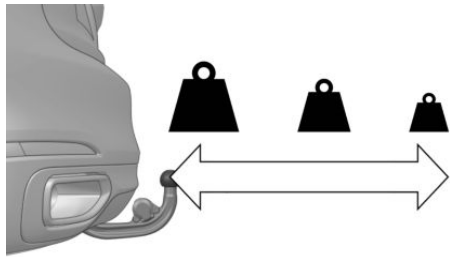

The permitted gross weight of the rear luggage rack when loaded depends on how far its centre of gravity is from the ball linkage.

- ▶ If the centre of gravity is up to 30 cm, approx. 11.8 in from the ball head, the total weight of the rear luggage rack must not exceed 75 kg/165 lbs.
- ▶ If the centre of gravity is 60 cm, approx. 23.5 in from the ball head, the total weight of the rear luggage rack must not exceed 35 kg/77 lbs.
- ▶ Stow heavy loads as close as possible to the ball linkage.
- ▶ Fasten loads securely to the rear luggage rack and secure them against sliding around.

Driving with a rear luggage rack

When laden, the rear luggage rack alters the vehicle's handling and steering response due to the centre of gravity having been shifted.

When loading and driving, bear the following in mind:

- ▶ Do not exceed the permitted axle load or the permitted gross weight.
- ▶ Drive smoothly and avoid sudden acceleration and braking or fast cornering.

Trailer operation

Vehicle equipment

This chapter describes all standard, country-specific and optional equipment available for the model series. It may therefore describe equipment and functions which are not installed in your vehicle, for example on account of the optional equipment selected or the national-market version. This also applies to safety-relevant functions and systems. Please comply with the relevant laws and regulations when using the corresponding functions and systems.

General

The permitted trailer loads, axle loads, trailer nose weights and gross vehicle weight rating are specified in the technical data.

Possibilities to increase are known to a Service Partner of the manufacturer or another qualified Service Partner or a specialist workshop.

The vehicle is equipped with reinforced springs on the rear axle and, depending on the type, with a more powerful cooling system.

For Australia/New Zealand: note

Towing

The Australian/New Zealand Standards AS 4177.1-2004 Caravan and light Towing a trailer components – trailer tow hitches and towing brackets contains the following statement, which is hereby accepted by the BMW Group Australia: FOR TOWING ONLY. The trailer tow hitch supplied with your BMW vehicle should only be used for towing purposes, the trailer tow hitch assembly should not be used in conjunction with any

towbar-mounted carrying device, such as, for example, a bicycle carrying rack.

As all BMW Group towbar assemblies are designed, tested and approved as a single unit, the practice of modifying or replacing the BMW supplied towball mount assembly is not approved. Use only the genuine BMW towball mount assembly.

BMW Group Australia does not recommend or support the installation and use of a Weight Distribution Hitch or Load Levelling Device on any BMW Group vehicle. The use of such devices may affect the vehicle's warranty status.

We recommend you consult your Authorised BMW Dealer for any further advice or clarification.

Before a journey

Trailer nose weight

The trailer nose weight should not be less than the minimum trailer nose weight of 25 kg, 55 lb. Utilise the maximum trailer nose weight as far as possible.

The weight of the trailer tow hitch and the nose weight reduce the maximum load of the towing vehicle. The nose weight increases the vehicle weight. The total permitted weight of the towing vehicle must not be exceeded.

Loads

Distribute the load as evenly as possible over the loading area.

Stow the load as low as possible and as close as possible to the trailer axle. A low centre of trailer gravity makes the car/trailer combination much more stable and safe to drive.

The permitted total weight of the trailer and the permitted trailer load of the vehicle must not be

exceeded. The lower value is the limit which should be adhered to.

Tyre inflation pressure

Check the vehicle's and the trailer's tyre inflation pressures carefully.

On the vehicle, the tyre inflation pressure, see page 262, for higher loads applies.

For the trailer, the regulations of the manufacturer apply.

Runflat indicator RPA

Initialise the runflat indicator after the tyre inflation pressure has been corrected or a trailer has been attached or detached.

Tyre Pressure Monitor TPM

Reset the Tyre Pressure Monitor after the tyre inflation pressure has been corrected or a trailer has been attached or detached.

Exterior mirrors

Two exterior mirrors which bring both rear corners of the trailer into your field of view are required by law. Mirrors of this type are available as special equipment from a Service Partner of the manufacturer or another qualified Service Partner or a specialist workshop.

Power consumption

Before beginning your journey, check the function of the trailer rear lights or the rear luggage rack lights.

Power of trailer rear lights or rear luggage rack lights must not exceed following values:

- ▶ Turn indicators: 42 watt per side.
- ▶ Tail lights: 50 watt per side.
- ▶ Brake lights: 84 watt total.
- ▶ Rear fog lights: 42 watt total.
- ▶ Reversing lights: 42 watt total.

To save vehicle battery power when the engine is off, keep the switch-on times of power consumers short.

Towing a trailer

General

When the trailer socket is in use, some driver assistance systems are unavailable, or available to a limited extent. A Check Control message is shown where applicable.

Safety notes

WARNING

Speeds in excess of approximately 80 km/h, 50 mph, can be enough to produce snaking motion, depending on the design of trailers and the loads they are carrying. There is a risk of accident or material damage.

Keep to an appropriate speed when towing a trailer. If the trailer starts to snake, brake immediately and make the necessary steering corrections as carefully as possible.

WARNING

The tyre inflation pressure must be adapted because of the increased axle load when towing a trailer. Driving with inadequate tyre inflation pressure can damage the tyres. There is a risk of accident or material damage. Do not exceed a speed of 100 km/h / 60 mph. Increase the tyre inflation pressure of the towing vehicle by 0.2 bar. Note the maximum possible tyre inflation pressure stated on the tyre.

NOTE

On long journeys with high trailer loads, a high outside temperature and a low fuel tank content, the fuel system can overheat leading to reduced engine power. There is a risk of material damage. Refuel in good time. Make sure that on long journeys with high trailer loads and a high outside temperature, the fuel tank is more than 1/4 full.

Upward gradients

In the interest of safety and to avoid holding up other traffic, do not attempt to climb upward gradients steeper than 12 % when towing a trailer.

If higher trailer loads have been retrospectively approved, the limit is 8%.

Driving off on upward gradients

With Steptronic transmission: The parking brake is automatically released when the accelerator pedal is pressed.

To prevent the vehicle from rolling back when driving off, use the parking brake.

1.  Shortly before driving off, pull and hold the switch.
The parking brake remains held as long as the switch is pulled.
2. To drive off, accelerate and release the switch.

Downhill gradients

On downward gradients, a car/trailer combination tends to start snaking earlier.

Before the downward gradient, shift down manually to the next-lowest gear and drive downwards slowly.

Trailer Stability Control**Principle**

The system helps you to neutralise a trailer's tendency to swing from side to side.

Trailer Stability Control detects snaking movements and promptly brakes the vehicle so that road speed falls to below the critical range and the car/trailer combination is stabilised.

General

If the power socket for the trailer is in use but no trailer is attached, for example when using a bicycle carrier with lighting, the system may become active in extreme driving situations.

Operating requirements

The system is operational from a speed of approximately 65 km/h, 40 mph, when towing a trailer and with the trailer socket in use.

System limits

The system is unable to intervene or intervenes too late, in the following situations for example:

- ▷ If a trailer folds instantly, for example on slippery or loose road surfaces.
- ▷ If a trailer with a high centre of gravity tips over before snaking is detected.
- ▷ If Dynamic Stability Control DSC is deactivated or has malfunctioned.
- ▷ If the power consumption of a trailer is too low to be detected by the system, for example due to LED rear lights.

Not for Australia/New Zealand: Trailer tow hitch

Safety notes

⚠ WARNING

Parts of the body can become trapped when inserting the ball linkage. There is a danger of injury. When inserting the ball linkage, make sure that the area of movement is kept clear.

⚠ WARNING

If the ball linkage is not locked, unstable driving conditions or accidents can result. There is a risk of accident or material damage. Before a journey with a trailer or load carrier, check that the ball linkage is correctly locked.

Storage

With spare wheel

Ball linkage is located under luggage compartment floor.

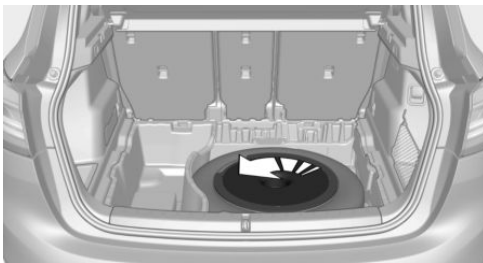

Undo the wing stud to remove the cover, arrow.

No spare wheel

Removable ball linkage is located under luggage compartment floor.

Ball linkage bracket

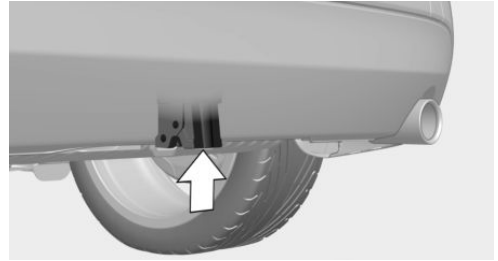

The bracket for the ball linkage is on the underside of the vehicle.

Follow the maintenance instructions, see page 312.

Overview

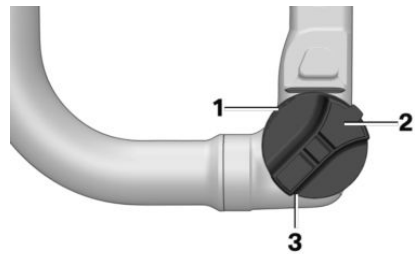

- 1 Lock display
- 2 Lock
- 3 Handwheel

Indicator on the ball linkage

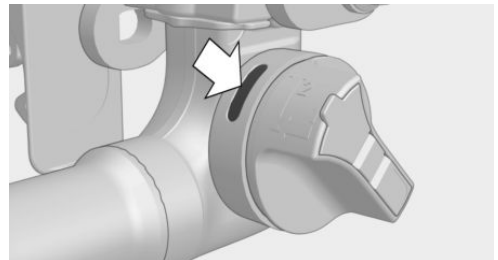

The colour of the indicator on the ball linkage shows the locking status.

Colour	Locking status
Red	Lock open, ball linkage can be inserted or removed.
Green	Lock closed, ball linkage is fitted firmly.
Orange	Lock closed, ball linkage is not fitted firmly.

Attaching ball linkage

Operating requirements

The ball linkage can be inserted if the following conditions are met:

- ▶ The lock is open.
- ▶ The indicator on the handwheel is red.

Opening the lock

Open the lock with the key supplied.

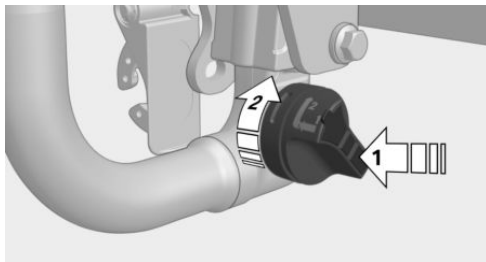

The lock is open if the handwheel can be pressed, arrow 1.

Pre-tensioning the handwheel

If the indicator is orange, pre-tension the handwheel:

1. Hold ball linkage firmly.

2. Press the handwheel, arrow 1, and turn in direction of the arrow as far as it will go, arrow 2.

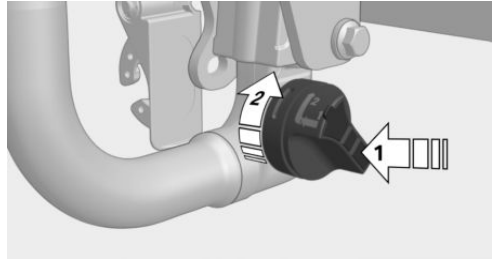

3. Handwheel engages.

Inserting ball linkage

1. Pull bracket cover downwards and store in the vehicle.

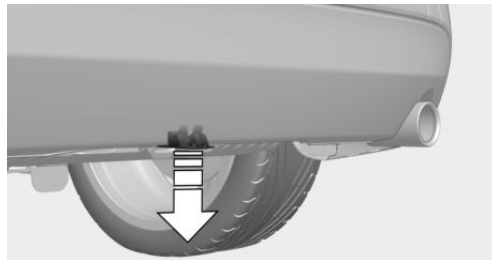

2. Insert the ball linkage from underneath into the bracket and push upwards, arrow 1.

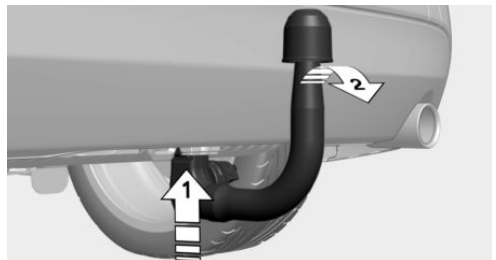

3. Pull the ball linkage backwards until it engages, arrow 2.

The ball linkage is inserted correctly if the indicator on the handwheel is green.

Locking the lock

The lock is used for preventing theft.

1. Insert the key into the lock.
2. Lock the lock in the handwheel.
3. Remove the key.

Checking the interlock

Ensure that the ball linkage is properly engaged by shaking it.

If the ball linkage is not fitted firmly, check the following points:

- ▶ The indicator on the handwheel is green.
- ▶ Ball linkage is lying flush in the bracket.
- ▶ The lock is locked and the key is removed.

If the indicator on the handwheel is not green, pre-tension the handwheel, see page 242.

If the ball linkage is not flush with the bracket, clean the bracket and the ball linkage, see page 312.

If the lock is locked, open it, see page 242.

Check with a Service Partner of the manufacturer or another qualified Service Partner or a specialist workshop if all points are met and the ball linkage is not firmly fitted.

Removing ball linkage

1. Fold up the lock cover.
2. Insert key and unlock the lock in the handwheel.
3. Remove the key.
4. Hold ball linkage firmly.

5. Press the handwheel, arrow 1, and turn in direction of arrow as far as it will go, arrow 2.

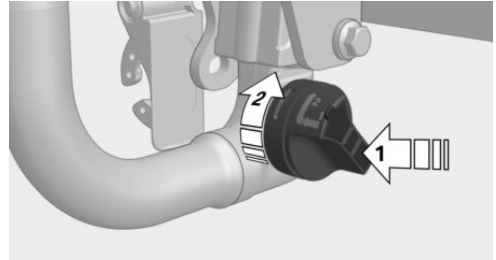

6. Pull the ball linkage out of the bracket.
7. Release the handwheel.
8. Insert cover in bracket.

Trailer socket

General

The socket is underneath the bumper next to the bracket for the ball linkage.

Safety notes

WARNING

The socket for the trailer or rear luggage rack can heat up due to exhaust gases. There is a danger of injury. Allow the trailer socket to cool before swivelling out.

WARNING

The socket for the trailer or rear luggage rack is located near to protruding parts of the vehicle body. There is a danger of injury. Do not touch any parts of the body when swivelling the trailer socket in and out.

Swivelling in and out

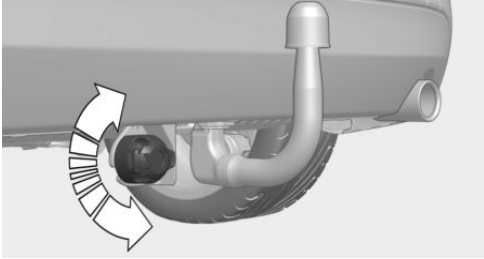

1. Grip the socket at the side.
2. Swivel the socket out or in up to the end position. To make it easier to swivel, pull the socket back slightly.

Eye for securing cable

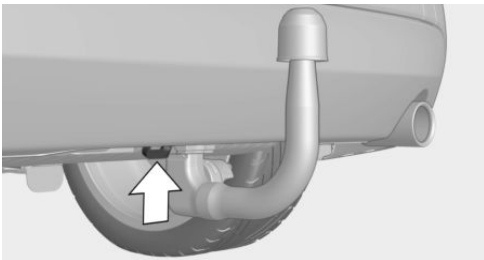

There is an eye on the trailer tow hitch bracket for attaching the trailer securing cable.

For increased safety when towing a trailer, attach the trailer securing cable to the eye.

Check that the securing cable can move freely and is not dragging on the ground.

Operating rear luggage racks

The ball linkage of the trailer tow hitch can be used as a mount for rear luggage racks; for example bicycle rack systems.

Note the information on rear luggage racks when operating the rear luggage rack, see page [233](#).

Reducing fuel consumption

Vehicle equipment

This chapter describes all standard, country-specific and optional equipment available for the model series. It may therefore describe equipment and functions which are not installed in your vehicle, for example on account of the optional equipment selected or the national-market version. This also applies to safety-relevant functions and systems. Please comply with the relevant laws and regulations when using the corresponding functions and systems.

General

The vehicle has a wide range of technologies for reducing consumption and emissions.

Fuel consumption depends on various factors.

A number of measures, such as a moderate driving style and regular maintenance, can influence fuel consumption and reduce the burden on the environment.

Remove unnecessary loads

Extra weight increases fuel consumption.

Remove mounted parts after use

If no longer required, remove auxiliary mirrors, roof racks and rear-mounted racks after use.

Remove unneeded roof racks after use.

Parts mounted on the vehicle can adversely affect its aerodynamic performance and increase fuel consumption.

Closing windows and the glass sunroof

An open glass sunroof or open window increase drag and consequently reduce the range.

Tyres

General

Tyres can have differing effects on consumption figures. Consumption can be affected by the size of the tyres, for example.

Check tyre inflation pressure regularly

Check and, if necessary, correct the tyre inflation pressures at least twice a month and before setting off on a longer journey.

Insufficient tyre inflation pressure increases rolling resistance and consequently fuel consumption and tyre wear.

Drive off immediately

Do not warm up the engine with the vehicle at a standstill, but instead set off straight away, driving at moderate engine speeds.

This brings the cold engine up to operating temperature as quickly as possible.

Think ahead

Anticipating the road situation and adopting a smooth driving style will reduce fuel consumption.

Avoid accelerating and braking unnecessarily.

Keep an appropriate distance from the vehicle ahead.

Avoid high engine speeds

Driving at low engine speeds reduces fuel consumption and wear.

Pay attention to the optimum shift indicator, see page 136, in the vehicle, if fitted.

Making use of overrun mode

When approaching a red traffic light, take your foot off the accelerator and allow the vehicle to roll.

On downward stretches, take your foot off the accelerator and allow the vehicle to roll.

The fuel supply is interrupted in overrun mode.

Switch off the engine if stopping for longer periods

Stopping the engine

When you stop the vehicle for longer periods, for example at traffic lights, railway crossings or in traffic jams, switch off the engine.

Automatic Start/Stop function

The Automatic Start/Stop function of the vehicle shuts off the engine automatically when stationary.

If the engine is switched off and then started again, the fuel consumption and emissions are reduced compared with a permanently running engine. Savings can be made just by stopping the engine for a few seconds.

Fuel consumption also depends on other factors, such as driving style, road condition, maintenance or environmental factors, for example.

Switch off functions which are not currently required

Functions such as seat heating or rear window heating require a great deal of energy and reduce the range, especially in city traffic and stop-and-go traffic.

Switch these functions off if they are not required.

The ECO PRO drive mode supports energy-saving use of comfort functions. These functions are automatically deactivated wholly or partially.

Have maintenance work carried out

Have the vehicle serviced regularly to achieve optimal economy and lifetime. BMW recommends having maintenance work carried out by a BMW Service Partner.

Please also see the BMW Maintenance System, see page 287.

ECO PRO

Principle

ECO PRO supports an efficient driving style. To achieve this, the engine management and comfort functions, for example the air conditioning power, are adapted.

In addition, messages to help you to drive with maximum efficiency can also be displayed in real time.

In the instrument cluster, the extension of the range achieved as a result can be displayed as a bonus range.

General

The system comprises the following EfficientDynamics functions and EfficientDynamics displays:

- ▷ ECO PRO bonus range, see page 248.
- ▷ Activate/deactivate the display, see page 248.
- ▷ ECO PRO air conditioning, see page 247.
- ▷ Route-ahead assistant, see page 249.
- ▷ Coasting drive state, see page 250.
- ▷ Driving style analysis, see page 251.

Overview



Driving Experience Control

Activating ECO PRO



Press the button until ECO PRO is displayed in the instrument cluster.

Configuring ECO PRO

Via the Driving Experience Control

1. Activating ECO PRO.
2. "Configure ECO PRO"
3. Select the desired setting.

Via iDrive

1. "My Vehicle"
2. "Vehicle settings"
3. If necessary, "Driving mode"
4. "Configure ECO PRO"
5. Select the desired setting.

The setting is saved for the current profile.

Enabling/disabling functions

The following functions can be activated/deactivated:

- ▷ "ECO PRO limit"
- ▷ "ECO PRO climate control"

The settings are saved for the current driver profile.

ECO PRO Limit

- ▷ "ECO PRO limit": activate ECO PRO limit.
An ECO PRO tip is shown when the speed of the set ECO PRO limit is exceeded.
- ▷ "Tip at:"
Set the required speed for the ECO PRO limit.

ECO PRO air conditioning

"ECO PRO climate control"

The air conditioning is adjusted for efficient consumption.

To achieve this, the set temperature is adjusted slightly and the interior is heated or cooled more slowly to reduce consumption.

The power to the seat heating and mirror heating is also reduced.

ECO PRO saving potential

The potential saving that can be achieved with the current configuration is shown as a percentage.

Display in the instrument cluster

ECO PRO bonus range



An extension of range can be achieved due to adjusted driving style.

The range extension can be displayed as bonus range in the instrument cluster.

The bonus range is contained in the display of the range.

After filling up, the bonus range is automatically reset.

ECO PRO efficiency display

The efficiency of the driving style is indicated by the colour of the ECO PRO displays in the instrument cluster:

- ▷ Blue display: efficient driving style.
- ▷ Grey display: adjust driving style, for example, by easing off the accelerator.

The colour changes to blue as soon as all the conditions for driving with optimised consumption are met.

Depending on the equipment, the ECO PRO display is also provide information about the current driving style. A needle moves on a scale for this purpose. The needle indicates whether energy is being consumed by acceleration, or energy is being recovered by rolling or braking. The driving style is efficient if the needle on the scale is moving within the blue band.

ECO PRO tip, driving note



The ECO PRO tip shows that the driving style can be adjusted to be more efficient on consumption, for example by accelerating less.





Activating/deactivating the display

Activate notes relating to the driving style and route-ahead assistant, as well as ECO PRO tips, in the instrument cluster using iDrive:

1. "My Vehicle"
2. "iDrive settings"
3. "Displays"
4. "Instrument cluster"
5. "ECO PRO information"

ECO PRO tip, symbols

An additional symbol and text instruction are shown.

Symbol	Action
	For an efficient driving style, ease off the accelerator and decelerate in an anticipatory manner.
	Reduce speed to the selected ECO PRO speed.
	Steptronic transmission: Shift from M/S to D and avoid manual changes.
	Manual transmission: Follow gearshift recommendation.
	Manual transmission: Engage neutral to stop engine.

Display on the control display

Displaying EfficientDynamics information

The current operating method of the ECO PRO functions can be shown on the control display.

Via iDrive:

1. "My Vehicle"
2. "Technology in action"

3. "EfficientDynamics"
4.  Select the symbol.

Following functions are displayed:

- ▶ Automatic Start/Stop function.
- ▶ Energy recuperation.
- ▶ Coasting.

Showing consumption history



The average consumption can be shown on the control display.

Via iDrive:



1. "My Vehicle"
2. "Technology in action"
3. "EfficientDynamics"
4.  Select the symbol.

Vertical bars shows the consumption for the selected time span.

Setting consumption history time span

1. "My Vehicle"
2. "Technology in action"
3. "EfficientDynamics"
4.  Select the symbol.
5.  Press the button.
6. Set time span.

Resetting consumption history

1. "My Vehicle"
2. "Technology in action"
3. "EfficientDynamics"
4.  Select the symbol.
5.  Press the button.
6. "Reset consumption history"

Route-ahead assistant

Principle

The system helps to save fuel and supports a precautionary driving style. Using the navigation data, certain sections of the route ahead can be detected early and information can be given. A corresponding tip is displayed.

The recognised sections of the route, such as built-up areas or bends ahead, for example, require a reduction in speed.

General

The alert is also given if the section of the route ahead cannot yet be detected when driving.

The alert is shown until the section of the route is reached.

If there is an instruction, the vehicle's speed and its consumption can be reduced by coming off the gas and rolling until the route section is reached.

Operating requirements

- ▶ ECO PRO driving mode is activated.
- ▶ The function must be available in the country in which the vehicle is being driven.

Display

Display in the instrument cluster



The note on a section of the route ahead is given as an ECO PRO trip for precautionary deceleration.

Activate the display, see page 248.



In the revolution counter, a long arrow up to the zero point of the efficiency display shows that a section of road in front has been detected.

Display in the Head-Up Display



The advance notice alert can also be shown in the Head-Up Display.

Display on the control display



The control display shows if there is a corresponding section of the route.

Call up driving style analysis display:

1. "My Vehicle"
2. "Technology in action"
3. "Driving style analysis"

Using route-ahead assistant

A section of the route ahead is shown:

1. Remove your foot from the accelerator.
2. Allow the vehicle to roll until you reach the section of road displayed.
3. Adjust the speed by braking as necessary.

System limits

The function is not available in the following situations:

- ▷ Speed below 50 km/h, 30 mph.
- ▷ In the area of temporary and variable speed limits, such as at road works.
- ▷ With inadequate quality of the navigation data.
- ▷ With Active Cruise Control.
- ▷ When towing a trailer.

Coasting

Principle

The engine is automatically disconnected from the gearbox in selector lever position D under certain circumstances. The vehicle continues to roll in neutral to reduce consumption. Selector lever position D remains engaged.

This drive state is called coasting.

As soon as the brake or accelerator pedal is pressed, the engine is automatically connected again.

General

Coasting is a component of the ECO PRO drive mode and the COMFORT drive mode.

Coasting is automatically activated by calling up the ECO PRO drive mode or COMFORT drive mode via the Driving Experience Control and cannot be deactivated.

A precautionary driving style helps to use the function as often as possible and supports the consumption-reducing effect of coasting.

Operating requirements

The function is available in the speed range from approx. 25 km/h, 15 mph up to 160 km/h, 100 mph.

The function is active if the following conditions are met:

- ▷ System detects a calm and smooth driving style.
- ▷ Accelerator pedal not pressed.
- ▷ Brake pedal not pressed or only pressed lightly.
- ▷ Selector lever in selector lever position D.
- ▷ Engine and gearbox are at operating temperature.

Operation via shift paddles

Principle

The coasting drive state can be controlled via the shift paddles, if installed.

Activating/deactivating coasting via shift paddles

1. Pull the right-hand shift paddle to shift to the top gear.
2. To activate coasting drive state, actuate the right-hand shift paddle again.

Actuate the left-hand shift paddle to deactivate.

Display

Display in the instrument cluster

The revolution counter is showing idle speed.

ECO PRO driving mode: The mark in the efficiency display has a blue background and is at zero. The coasting point display is illuminated at zero when coasting.

Display on the control display

In EfficientDynamics, the coasting drive state is shown during the journey.

The route covered in the coasting drive state is displayed in the consumption history. The counter reading is reset before the start of each journey.

Displaying EfficientDynamics information

Via iDrive:

1. "My Vehicle"
2. "Technology in action"
3. "EfficientDynamics"
4.  Select the symbol.

System limits

The function is not available if one of the following conditions is met:

- ▷ If DSC OFF or TRACTION is activated.
- ▷ If Cruise Control is activated.
- ▷ When driving in the handling limit range.
- ▷ When driving on steep uphill or downhill inclines.
- ▷ When towing a trailer.
- ▷ If the battery charge state is temporarily too low.
- ▷ If the vehicle's electrical system is drawing too much current.

Driving style analysis

Principle

The function helps you to develop a particularly efficient driving style and to save fuel.

To do this, the driving style is analysed. The evaluation is performed in various categories and is shown on the control display.

Using this display, the individual driving style can be adjusted to save fuel.

The last 15 minutes of a journey are evaluated.

The range of the vehicle can be increased by adopting an efficient driving style.

This gain in range is shown as a bonus range on the instrument cluster and control display.

Operating requirements

The function is available in ECO PRO drive mode.

Calling up ECO PRO driving style analysis

Via iDrive:

1. "My Vehicle"
2. "Technology in action"

3. "Driving style analysis"

Display on the control display

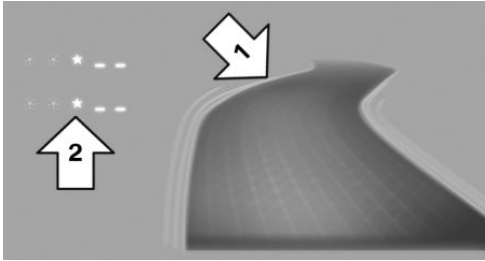

The display of the ECO PRO driving style analyser consists of a symbolised road and a performance table.

The road symbolises the efficiency of the driving style. The more efficient the driving style, the more evenly the route is illustrated, arrow 1.

The performance table contains stars. The more efficient the driving style, the more stars are contained in the table and the faster the bonus range increases, arrow 2.

On the other hand, if the driving style is inefficient, a bumpier road and a reduced number of stars is shown.

To support an efficient driving style, ECO PRO tips are shown during the journey.

Tips for an energy-saving driving style, Saving fuel, see page [245](#).

Refuelling

Vehicle equipment

This chapter describes all standard, country-specific and optional equipment available for the model series. It may therefore describe equipment and functions which are not installed in your vehicle, for example on account of the optional equipment selected or the national-market version. This also applies to safety-relevant functions and systems. Please comply with the relevant laws and regulations when using the corresponding functions and systems.

General

Before refuelling, observe the notes on fuel quality, see page 256.

On vehicles with diesel engines, the fuel filler neck is designed for refuelling at diesel pumps.

Safety note

NOTE

If the range drops below 50 km, 30 miles, the engine may no longer be supplied with sufficient fuel. Engine function is no longer ensured. There is a risk of material damage. Refuel in good time.

Fuel filler cap

Opening

1. To open the fuel tank filler flap, push on the upper edge, arrow. The fuel tank filler flap opens.



2. Turn the fuel filler cap anticlockwise.

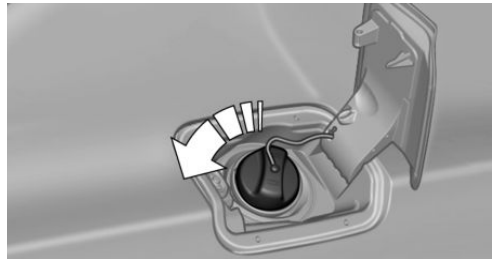

3. Place the fuel filler cap in the holder on the fuel tank filler flap.

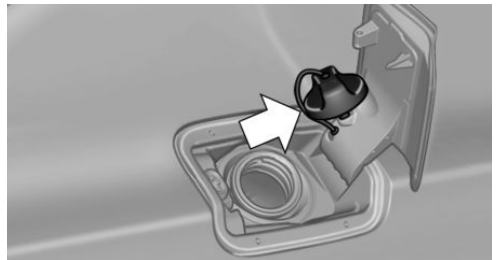

Closing

WARNING

The retaining strap of the fuel filler cap may become trapped and crushed when turning the cap to close it. It will then not be possible to close the cap properly. Fuel or fuel vapours can leak out. There is a risk of injury or material damage. Make sure that the retaining strap does not get trapped and crushed when closing the cap.

1. Fit the tank cap and turn clockwise until it is clearly heard to click into place.
2. Press on the fuel tank filler flap until it engages.

Emergency release

In certain situations, it may be necessary to unlock the fuel tank filler flap manually, for example if there is an electrical fault.

Have the fuel tank filler flap unlocked by a Service Partner of the manufacturer or another qualified Service Partner or a specialist workshop.

Notes when refuelling

General

When refuelling, insert the filler nozzle fully into the filler neck. Lifting the filler nozzle during refuelling results in the following:

- ▷ The supply of fuel is stopped too soon.
- ▷ Fuel vapour recovery is less effective.

The fuel tank is full when the filler nozzle cuts out for the first time.

Please comply with the safety regulations displayed at filling stations.

Safety note

NOTE

Fuels are poisonous and aggressive substances. Overfilling the fuel tank can damage the fuel system. If fuel comes into contact with paintwork, it can damage it. The environment is polluted. There is a risk of material damage. Avoid overfilling.

Fuel

Vehicle equipment

This chapter describes all standard, country-specific and optional equipment available for the model series. It may therefore describe equipment and functions which are not installed in your vehicle, for example on account of the optional equipment selected or the national-market version. This also applies to safety-relevant functions and systems. Please comply with the relevant laws and regulations when using the corresponding functions and systems.

Fuel quality

General

Depending on the region, many filling stations sell fuel that is adapted to winter or summer conditions. Fuel that is sold in winter helps with cold starting, for example.

Petrol

General

For optimal fuel consumption, the petrol should be sulphur-free or have a low sulphur content.

Fuels labelled on the pump as containing metal must not be used.

You can fill up with fuels with a maximum ethanol content of 25 %, for example E10 or E25.



The engine has knock control. This means that different petrol grades can be used.

Safety notes

⚠ NOTE

The fuel system and engine can be damaged by the wrong fuel, even in small quantities, and by the wrong fuel additives. In addition, the catalytic converter will be permanently damaged. There is a risk of material damage. For petrol engines, do not refuel with or add the following:

- ▷ Leaded petrol.
- ▷ Metallic additives, for example manganese or iron.

After filling with the wrong fuel, do not press the Start/Stop button. Contact a Service Partner of the manufacturer or another qualified Service Partner or a specialist workshop.

⚠ NOTE

Incorrect fuels can damage the fuel system and engine. There is a risk of material damage. Do not refuel with fuel with a higher ethanol content than recommended. Do not refuel with fuel containing methanol, for example M5 to M100.

⚠ NOTE

Fuel below the specified minimum quality can adversely affect engine function or lead to engine damage. There is a risk of material damage. Do not refuel below the specified minimum quality.

Petrol grade

The engine is designed to run on petrol to DIN EN 228.

Super, RON 95.

Use this fuel to achieve the rated performance and consumption figures.

Minimum grade

Unleaded petrol, RON 91.

Diesel

Safety note

NOTE

The fuel system and engine can be damaged by the wrong fuel, even in small quantities, and by the wrong fuel additives. There is a risk of material damage.

Note the following with diesel engines:

- ▷ Do not fill up with pure methyl ester.
- ▷ Do not fill up with petrol.
- ▷ The vehicle manufacturer recommends only using diesel additives that have been classified as suitable.

After filling with the wrong fuel, do not press the Start/Stop button. Contact a Service Partner of the manufacturer or another qualified Service Partner or a specialist workshop.

Diesel quality

The engine is designed to run on diesel fuel as per DIN EN 590 and ASTM D975.

Diesel with up to 7 % biodiesel (B7).



Minimum grade

Diesel with up to 10 % biodiesel (B10).
Paraffinic diesel fuel as per EN 15940.

BMW recommends Shell Quality Fuels

BMW Diesel with BluePerformance

Principle

BMW Diesel with BluePerformance reduces nitrous oxides in the diesel exhaust by injecting the reduction agent AdBlue into the exhaust stream. In the catalytic converter, this produces a chemical reaction that minimises the nitrous oxides.

General

The vehicle has a tank which has to be topped up.

To start the engine normally, sufficient reduction agent must be present.

Reduction agent can be topped up at any time.

AdBlue is a registered trademark of the Verband der Automobilindustrie e. V. (VDA).

Reduction agent is available at many service stations.

Preferably add reduction agent at a pump dispenser, see page 259.

AdBlue at low temperatures

Due to its physical properties, it is possible that reduction agent has to be topped up more frequently at temperatures below -5 °C/+23 °F.

At temperatures below $-11\text{ }^{\circ}\text{C}/+12\text{ }^{\circ}\text{F}$, it might only be possible to measure and display the fill level after a short journey. The range displayed may reduce significantly.

At low temperatures, only top up with reduction agent directly before starting the trip.

Display on the control display

Range

The range until the latest possible top-up time is displayed. The amount to top up may be displayed.

Reduction agent can be topped up at any time.

Via iDrive:

1. "My Vehicle"
2. "Vehicle status"
3. "AdBlue"

If the filling level is too low, Check Control message is displayed.

Displays in the instrument cluster

Reserve level indicator

The reserve level indicator in the instrument cluster notifies you if there is a low level of reducing agent in the tank.

Do not run down the reducing agent tank until it is completely empty, as it will not be possible to start the engine after stopping it.

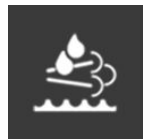

A yellow warning lamp is illuminated in the instrument cluster: filling level too low. Remaining range is shown in instrument cluster.

Top up with at least 5 litres, approx. 1.3 gal of reducing agent immediately.

AdBlue on the minimum level



Tank for reducing agent is empty. Immediately add at least 10 litres, approx. 2.6 gal of reducing agent.

Engine continues to run, as long as it is not stopped and all other operating conditions are met, for example, enough fuel.

System fault

If there is a system fault, a Check Control message is displayed.

Visit the nearest Service Partner of the manufacturer or another qualified Service Partner or a specialist workshop.

AdBlue topping up

BMW recommends having the reduction agent replenished by a Service Partner as part of a regular maintenance schedule.

If you keep to this maintenance schedule, a single top-up is generally required between the maintenance appointments.

Under certain circumstances, for example due to particularly dynamic driving style or operating the vehicle with a trailer, topping up between maintenance appointments more than once may be necessary.

As soon as the reserve level indicator is shown in the instrument cluster, have the reduction agent topped up, to prevent the vehicle from no longer being able to be started.

Topping up AdBlue yourself

Safety notes

WARNING

When the reduction agent container is opened, small quantities of ammonia vapours can emerge. Ammonia vapours have a pungent smell and irritate the skin, mucous membranes and eyes. There is a danger of injury. Do not in-

hale ammonia vapours. Do not allow reduction agent to come into contact with clothing, skin or eyes, and do not swallow it. Keep children away from reduction agents.

⚠ WARNING

Operating fluids, for example oils, greases, coolants and fuels, can contain substances that are harmful to health. There is a risk of injury or even death. Please comply with the instructions on the containers. Do not allow operating fluids to come into contact with clothing, skin or eyes. Do not pour operating fluids into other bottles. Keep operating fluids out of the reach of children.

⚠ NOTE

The constituents of reduction agent are highly aggressive. There is a risk of material damage. Avoid contact of reduction agent with surfaces of the vehicle.

Suitable AdBlue

- ▶ AdBlue of standard ISO 22241-1

At many service stations, reduction agent is available at a special pump dispenser. Preferably add reduction agent at a pump dispenser.

If no pump dispenser is available, reduction agent can be replenished from a container. Reduction agent is available in various containers. Preferably use the special bottle recommended by BMW. With this bottle and its special adapter, reduction agent can be topped up conveniently.

Top up quantity

When the reserve level indicator starts, top up at least 5 litres, approx. 1.3 gal.

Indicating top-up quantity

Precise top-up quantity is shown on control display.

Via iDrive:

1. "My Vehicle"
2. "Vehicle status"
3. "AdBlue"

Replenishing reduction agent at the pump dispenser

General

When refuelling, insert the filler nozzle fully into the filler neck. Lifting the filler nozzle during refuelling results in the following:

- ▶ The supply of fuel is stopped too soon.
- ▶ Overflow of reducing agent.

The tank for the reducing agent is full when the filler nozzle cuts out for the first time.

Please comply with the safety regulations displayed at filling stations.

Adding reducing agent

1. Open fuel tank filler flap, see page 254.
2. Turn the reduction agent tank cap anticlockwise and remove.

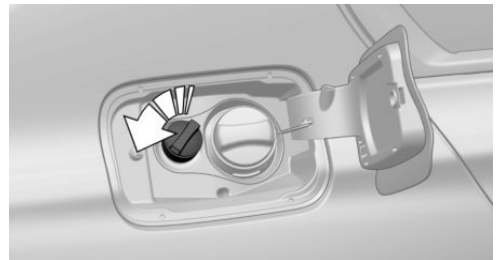

- Place the fuel filler cap in the holder on the fuel tank filler flap.

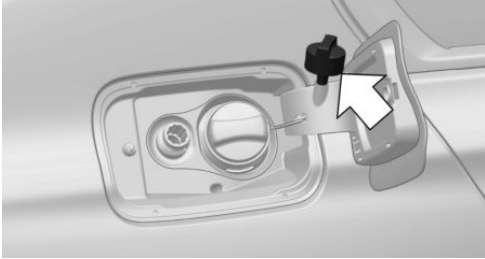

- Use the pump nozzle to replenish at least the recommended top-up quantity, see page 259.

The tank is full when the filler nozzle cuts out for the first time.

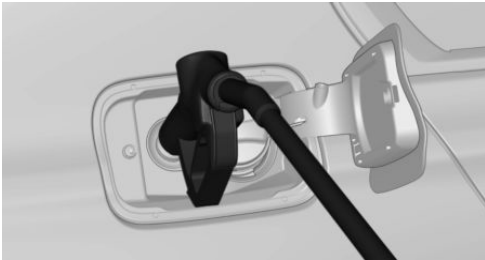

- Put fuel filler cap back on and turn clockwise.
- Press on the fuel tank filler flap until it engages.

Replenishing diesel exhaust fluid using a bottle

- Open fuel tank filler flap, see page 254.
- Turn the reduction agent tank cap anticlockwise and remove.

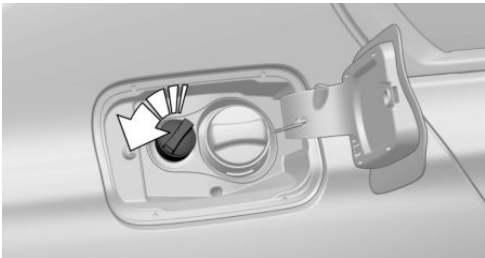

- Place the fuel filler cap in the holder on the fuel tank filler flap.

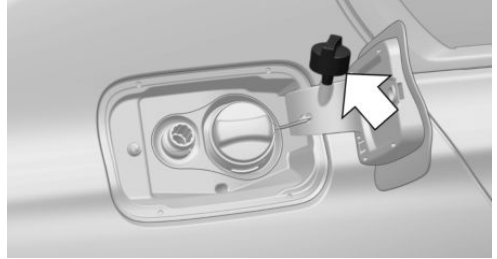

- Fit bottle and turn until it stops, see arrow.



- Press the bottom of the bottle, see arrow.

The tank in the vehicle is filled.

The tank in the vehicle is filled when the level in the bottle does not change any more. It is not possible to overfill.



- Pull back bottle, see arrow, and unscrew.

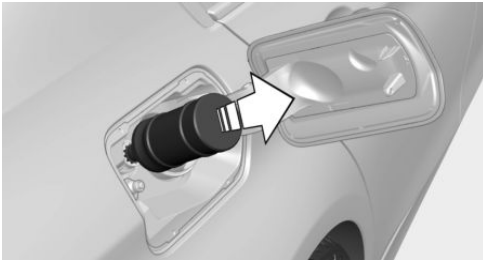

- Put fuel filler cap back on and turn clockwise.
- Press on the fuel tank filler flap until it engages.

Filling with an incorrect fluid

General

A Check Control message is displayed if the tank has been filled with the wrong fluid.

If the wrong type of liquid has been added, contact a Service Partner of the manufacturer or another qualified Service Partner or a specialist workshop.

Safety note

WARNING

After filling with an incorrect liquid, the system may heat up and catch fire. There is a risk of fire and danger of injury. Only fill with liquids that are intended for the tank. Do not start the engine after filling with an incorrect liquid.

After filling reduction agent

Reserve level indicator



After topping up, the reserve level indicator continues to be shown with remaining range.

Engine can be started.

After a journey of several minutes, the reserve level indicator goes out.

AdBlue on the minimum level



After filling up, the display continues to be shown.

Engine can only be started when the display is no longer illuminated.

- Switch on the ignition.
Display is no longer illuminated after approximately 1 minute.
- Engine can be started.

Disposing of bottles



Bottles for AdBlue can be disposed of at a Service Partner of the manufacturer or another qualified Service Partner or a specialist workshop.

Only dispose of bottles with normal waste if the local regulations permit this.

Wheels and tyres

Vehicle equipment

This chapter describes all standard, country-specific and optional equipment available for the model series. It may therefore describe equipment and functions which are not installed in your vehicle, for example on account of the optional equipment selected or the national-market version. This also applies to safety-relevant functions and systems. Please comply with the relevant laws and regulations when using the corresponding functions and systems.

Tyre inflation pressure

General

The tyre inflation pressure and tyre condition influence the following:

- ▷ Lifetime of the tyre.
- ▷ Driving safety.
- ▷ Driving comfort.
- ▷ Driving dynamics.
- ▷ Fuel consumption.

Safety note

WARNING

A tyre with too little or no tyre inflation pressure can heat up significantly and sustain damage. Handling characteristics, for example steering and braking, will be impaired as a result. There is a risk of accident. Check the tyre inflation pressure regularly and adjust as necessary, for example twice a month or before any long journey.

Tyre inflation pressure information

On the body pillar



The tyre inflation pressure information is located on the body pillar of the driver's door.

The tyre inflation pressure data is valid for the tyre sizes and recommended tyre makes which have been rated by the vehicle manufacturer as suitable for the vehicle type concerned.

If the tyre's speed code letter cannot be found, then the tyre inflation pressure for the corresponding tyre size applies.

The tyre inflation pressure appropriate for the respective load conditions should be used. For example, if the vehicle is partially loaded, use the tyre inflation pressure specified for a partially loaded vehicle.

When the vehicle is partially loaded, the lowest possible fuel consumption can be achieved with the ECO tyre inflation pressure.

More information regarding wheels and tyres can be obtained from a Service Partner of the manufacturer or another qualified Service Partner or a specialist workshop.

For Australia/New Zealand

WARNING

The inflation pressures on the tyre label are applicable only for tyres explicitly mentioned on the label. Inflation pressures for tyres that may be covered by the label – by size, speed category and load rating/load index – but not explicitly mentioned on the label may be different. Please obtain adequate inflation pressures in accordance with the tyre manufacturer's specifications from your tyre dealer.

Checking the tyre inflation pressure

General

Tyres heat up while driving. The tyre inflation pressure increases with the temperature of the tyre.

Tyres have a natural, uniform loss of tyre inflation pressure.

Inflating devices can display a pressure that may be up to 0.1 bar too low.

Checking using tyre inflation pressure information on the door pillar

The tyre inflation pressure information on the tyre inflation pressure plate on the door pillar only relates to cold tyres or tyres at the same temperature as the ambient temperature.

Only check the tyre inflation pressures when the tyres are cold, i.e.:

- ▶ If the vehicle has been driven a distance of no more than 2 km, 1.25 miles.
- ▶ If the vehicle has not moved again for at least 2 hours after a journey.

Additionally, regularly check the tyre inflation pressure of the spare wheel in the luggage compartment and correct the pressure if necessary.

1. Determine the specified tyre inflation pressures for the tyres installed on the vehicle.
2. Check the tyre inflation pressure in all four tyres, using a pressure gauge, for example.
3. Correct the tyre inflation pressure if the current tyre inflation pressure deviates from the specified tyre inflation pressure.
4. Check whether all valve caps are screwed onto the tyre valves.

After adjusting the tyre inflation pressure

For the runflat indicator RPA: reinitialise the runflat indicator RPA.

For the Tyre Pressure Monitor TPM: reset the Tyre Pressure Monitor TPM.

Speed code

Designation	Maximum speed
Q	up to 160 km/h, 100 mph
R	up to 170 km/h, 106 mph
S	up to 180 km/h, 112 mph
T	up to 190 km/h, 118 mph
H	up to 210 km/h, 131 mph
F	up to 240 km/h, 150 mph
W	up to 270 km/h, 167 mph
Y	up to 300 km/h, 186 mph

Tyre tread

Summer tyres

The tyre tread depth should not be less than 3 mm, 0.12 in, otherwise there is a high risk of aquaplaning.

Winter tyres

The tyre tread depth should not be less than 4 mm, 0.16 in, otherwise its suitability for winter use is limited.

Minimum tread depth

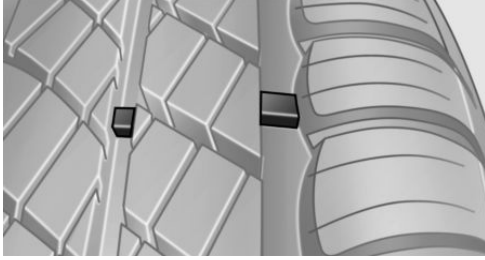

Wear displays are distributed across the tyre circumference and have the legally prescribed minimum height of 1.6 mm, 0.06 in.

The positions of the wear indicators are identified on the tyre's side wall by TWI, Tread Wear Indicator.

Tyre damage

General

Inspect tyres regularly for damage, the presence of foreign bodies and wear.

Vehicle behaviour that may indicate tyre damage or other faults:

- ▷ Unusual vibrations.
- ▷ Unusual tyre or running noises.
- ▷ Unusual vehicle response, such as pronounced pulling to the left or right.

Damage can be caused by the following situations, for example:

- ▷ Driving over kerbs.
- ▷ Road damage.
- ▷ Insufficient tyre inflation pressure.
- ▷ Overloading the vehicle.
- ▷ Incorrect tyre storage.

Safety notes

WARNING

If the tyres are damaged, the tyre inflation pressure may be reduced, which in turn could cause you to lose control of the vehicle. There is a risk of accident. If you suspect tyre damage while you are driving, immediately reduce speed and bring the vehicle to a stop. Have the wheels and tyres checked. To do so, carefully drive to a Service Partner of the manufacturer or another qualified Service Partner or a specialist workshop. If necessary, have the vehicle towed or transported there. Do not repair damaged tyres. Have them replaced.

WARNING

Tyres can become damaged by driving over obstacles, for example kerbs or damaged road surfaces, at high speed. Larger wheels have a smaller tyre cross-section. The smaller the tyre cross-section, the higher the risk of tyre damage. There is a risk of accident and material damage. If possible, drive around obstacles or drive over them slowly and carefully.

Age of tyres

Recommendation

Irrespective of the tyre tread depth, change tyres after 6 years at the latest.

Date of manufacture

The date of manufacture of the tyre is indicated on the tyre sidewall.

Designation	Date of manufacture
DOT ... 0121	1st week of 2021

Replacement of wheels and tyres

Fitting

Have the wheel fitted and balanced by a Service Partner of the manufacturer or another qualified Service Partner or a specialist workshop.

Wheel/tyre combination

General

Information on the correct wheel/tyre combination and rim designs for the vehicle can be obtained from a Service Partner of the manufacturer or another qualified Service Partner or a specialist workshop.

Safety notes

WARNING

Wheels and tyres that are not suitable for the vehicle can damage parts of the vehicle. For example they could come into contact with the bodywork on account of their dimensional tolerances, despite having the same nominal size. There is a risk of accident. The manufacturer of the vehicle recommends using wheels and tyres that have been rated as suitable for the vehicle concerned.

WARNING

Incorrect wheel and tyre combinations impair the vehicle's driving characteristics and interfere with the proper functioning of various systems, such as the Anti-lock Brake System ABS or Dynamic Stability Control DSC. There is a risk of accident. To maintain good vehicle handling, always fit tyres of the same make and tread pattern to all wheels. The manufacturer of the vehicle recommends using wheels and tyres that have been rated as suitable for the vehicle concerned. After a tyre has been dam-

aged, refit the same wheel/tyre combination as the original.

Recommended makes of tyre



Certain makes of tyre are recommended by the manufacturer of the vehicle for each tyre size. The tyre brands can be identified by a star on the side wall of the tyre.

New tyres

Due to the manufacturing process, new tyres do not achieve their full road grip immediately.

Drive moderately for the first 300 km, 200 miles.

Retreaded tyres

WARNING

Retreaded tyres may have different tyre carcasses. Their durability may be reduced due to their advanced age. There is a risk of accident. Do not use retreaded tyres.

The vehicle manufacturer advises against the use of retreaded tyres.

Winter tyres

Winter tyres are recommended if driving in winter conditions.

Although tyres known as all-season tyres with an M+S label have better winter characteristics than summer tyres, they do not normally match the performance of winter tyres.

Maximum speed of winter tyres

If the vehicle is capable of maximum speeds higher than the speed permitted for the winter tyres, an information label stating the maximum permitted speed for the tyres fitted must be displayed in the driver's field of view. The label is available from a Service Partner of the manufacturer or another qualified Service Partner or a specialist workshop.

If winter tyres are fitted, observe and do not exceed the respectively permitted maximum speed.

Replacing run-flat tyres

When changing from run-flat tyres to standard tyres, make sure that a spare wheel or a flat tyre kit is available in the vehicle. Additional information is available from a Service Partner of the manufacturer or another qualified Service Partner or a specialist workshop.

Rotating wheels between axles

Depending on the individual operating conditions, the tyre tread wears differently on the front and rear wheels. To achieve even wear, the tyres can be rotated in pairs between the axles. Additional information is available from a Service Partner of the manufacturer or another qualified Service Partner or a specialist workshop. After rotation, check the tyre inflation pressure and adjust if necessary.

Storing tyres

Tyre inflation pressure

Do not exceed the maximum tyre inflation pressure indicated on the tyre's side wall.

Tyre storage

- ▷ Store wheels and tyres in a cool, dry and dark place when not in use.
- ▷ Protect the tyres against contamination from oil, grease and solvents.

- ▷ Do not leave tyres in plastic bags.
- ▷ Remove dirt from the wheels or tyres.

Run-flat tyres

Principle

In the event of a complete loss of tyre inflation pressure, run-flat tyres enable you to continue driving, with certain restrictions.

General

The wheels are fitted with tyres which are self-supporting to a limited degree. They may also have special rims.

The reinforced side wall means that the tyre keeps the vehicle mobile to a degree, even if tyre inflation pressure has been lost.

Observe the notes on continuing to drive with a flat tyre.

Safety notes

WARNING

A run-flat tyre with too little or no tyre inflation pressure will change the vehicle's handling characteristics, for example there may be reduced directional stability when braking, longer braking distances and different self-steering characteristics. There is a risk of accident. Drive with care and do not exceed a speed of 80 km/h, 50 mph.

WARNING

Continuing to drive with a flat tyre can result in heavy trailers starting to slalom. There is a risk of accident or material damage. When driving with a trailer and a flat tyre, do not exceed the speed of 60 km/h, 35 mph. If the trailer starts to snake, brake immediately and make the neces-

sary steering corrections as carefully as possible.

Identification



The tyres are identified on the tyre's side wall by RSC Runflat System Component.

Remedying flat tyres

Safety measures

- ▶ Park the vehicle on a firm surface and as far away from moving traffic as possible.
- ▶ Switch on the hazard warning lights.
- ▶ Apply the parking brake to prevent the vehicle rolling away.
- ▶ Engage the steering wheel lock with the wheels in the straight-ahead position.
- ▶ Have all vehicle occupants get out of the vehicle and guide them out of the danger area, for example behind the crash barrier.
- ▶ Set up the warning triangle an appropriate distance away.

Mobility System

Principle

With the Mobility System, minor tyre damage can be quickly sealed, to allow you to drive on. For this purpose, liquid sealant is pumped into

the tyres which encloses the damage from the inside when it hardens.

General

- ▶ Please observe the notes on using the Mobility System which are on the compressor and the sealant container.
- ▶ Using the Mobility System can be ineffective for tyre damage larger than approximately 4 mm.
- ▶ Contact a Service Partner of the manufacturer or another qualified Service Partner or a specialist workshop if you are unable to put the tyre back in operation.
- ▶ Foreign bodies that have penetrated the tyre should remain inside the tyre. Only remove foreign objects if they are visibly protruding from the tyre.
- ▶ Remove the speed limit sticker from the sealant container and attach to the steering wheel.
- ▶ Using sealants can damage the TPM wheel electronics. In this case, have the TPM wheel electronics replaced at the next opportunity.
- ▶ The compressor can be used to check the tyre inflation pressure.

Overview

Storage

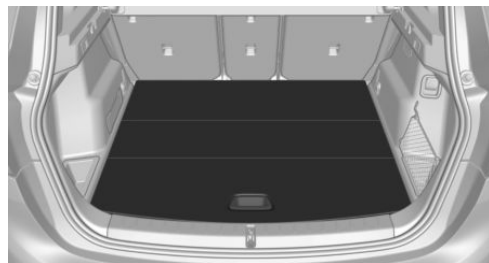

The Mobility System is located under the luggage compartment floor.

Sealant container

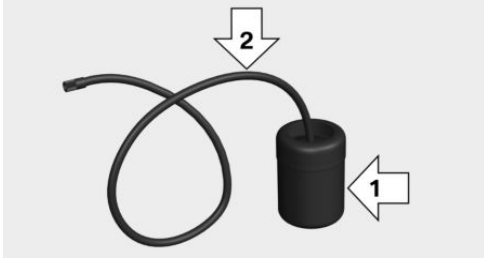

- ▷ Sealant container, arrow 1.
- ▷ Filler hose, arrow 2.

Note the use-by date on the sealant container.

Compressor

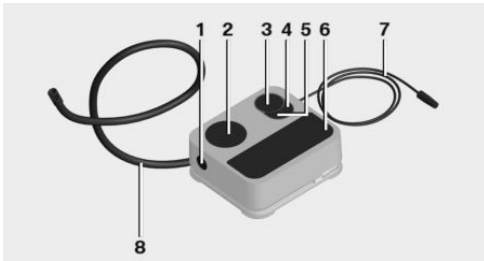

- 1 To unlock sealant container
- 2 Sealant container holder
- 3 Tyre inflation pressure indicator
- 4 Button for reducing the tyre inflation pressure
- 5 On/Off button
- 6 Compressor
- 7 Plug/cable for socket
- 8 Connecting hose

Filling with sealing compound

Safety notes

⚠ DANGER

A blocked exhaust pipe or inadequate ventilation can allow harmful exhaust fumes to enter the vehicle. The exhaust fumes contain pollutants which are colourless and odourless. In enclosed spaces, exhaust fumes can also build up outside the vehicle. There is a risk of death. Keep the exhaust pipe clear and ensure sufficient ventilation.

⚠ NOTE

The compressor can overheat if operated for too long. There is a risk of material damage. Do not let the compressor run for longer than 10 minutes.

Filling

1. Shake the sealant container.

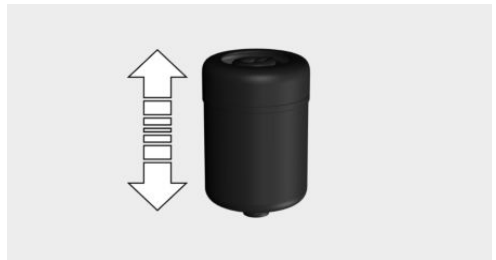

- Pull filler hose completely out of the cover of the sealant container. Do not kink the hose.

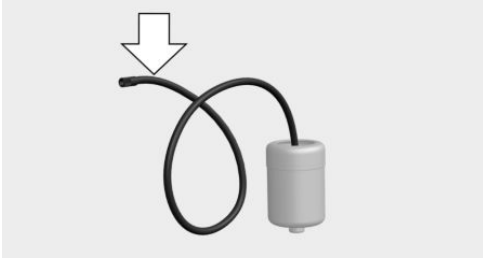

- Push the sealant container into the bracket on the compressor housing, until it audibly engages.

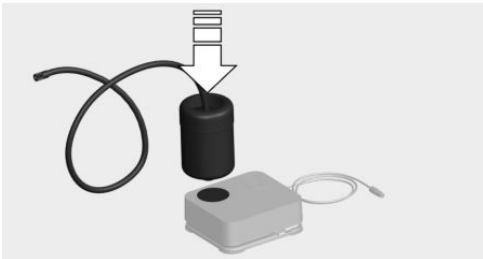

- Screw the filler hose of the sealant container onto the tyre valve of the faulty wheel.

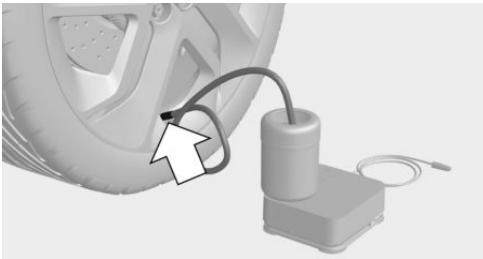

- With the compressor switched off, insert the plug into the socket inside the vehicle.

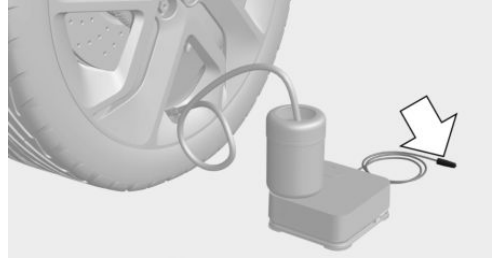

- With the ignition switched on or the engine running, switch on the compressor.

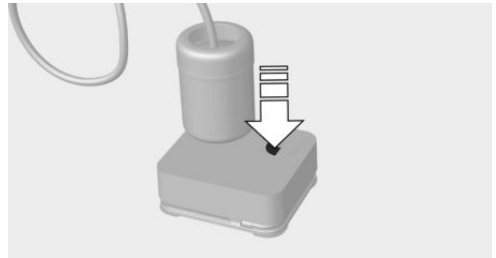

Let the compressor run for a maximum of 10 minutes to fill the sealing compound and achieve a tyre inflation pressure of approximately 2.0 bar.

The tyre inflation pressure may rise to approximately 5 bar during the filling process of the sealing compound. Do not switch off the compressor during this step.

Checking and adjusting the tyre inflation pressure

Checking

- Switch off compressor.
- Read off the tyre inflation pressure as shown on the tyre pressure indicator.

To be able to continue the journey, a tyre inflation pressure of at least 2 bar must be reached.

Removing and storing the sealant container

1. Unscrew the filler hose of the sealant container from the tyre valve.
2. Press the red unlocking device.
3. Remove the sealant container from the compressor.
4. Pack and store the sealant container to avoid soiling the luggage compartment.

Minimum tyre inflation pressure is not reached

1. Remove the plug from the socket inside the vehicle.
2. Drive forwards and backwards by 10 m, 400 inches, to distribute the sealant in the tyre.
3. Screw the connecting hose of the compressor directly onto the tyre valve.

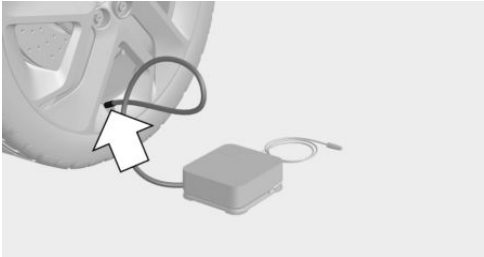

4. Insert the plug into the socket inside the vehicle.

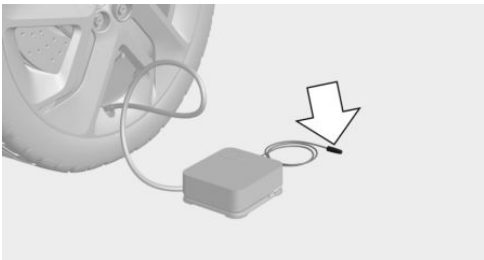

5. With the ignition switched on or the engine running, switch on the compressor.

If the tyre inflation pressure of at least 2 bar is not reached, contact a Service Partner of the manufacturer or a qualified Service Partner or a specialist workshop.

If the tyre inflation pressure of at least 2 bar is reached, see Minimum tyre inflation pressure is reached.

6. Remove the connecting hose of the compressor from the tyre valve.
7. Remove the plug from the socket inside the vehicle.
8. Store Mobility System in the vehicle.

Minimum tyre inflation pressure is reached

1. Unscrew the connecting hose of the compressor from the tyre valve.
2. Remove the plug from the socket inside the vehicle.
3. Store Mobility System in the vehicle.
4. Immediately drive for approximately 10 km/5 mi to evenly distribute the sealing compound in the tyre.

Do not exceed a speed of 80 km/h/50 mph.

If possible, do not drive slower than 20 km/h/12 mph.

Adjusting

1. Stop in a suitable area.
2. Screw the connecting hose of the compressor directly onto the tyre valve.

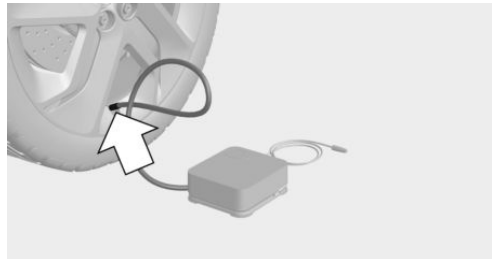

3. Insert the plug into the socket inside the vehicle.

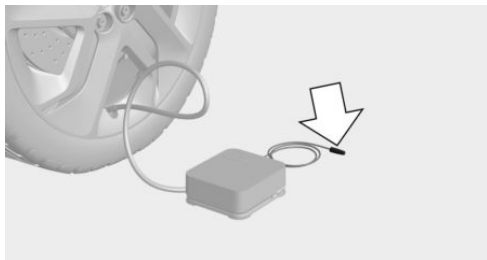

4. Correct the tyre inflation pressure to at least 2.0 bar.
 - ▷ To increase the tyre inflation pressure: switch on the compressor with the engine running or the ignition switched on.
 - ▷ To reduce pressure: press the button on the compressor.
5. Remove the connecting hose of the compressor from the tyre valve.
6. Remove the plug from the socket inside the vehicle.
7. Store Mobility System in the vehicle.

Resuming a journey

Do not exceed maximum permitted speed of 80 km/h, 50 mph.

Reinitialise the runflat indicator RPA.

Reset the Tyre Pressure Monitor TPM.

Have the faulty tyre and the sealant container of the Mobility System replaced at the next opportunity.

Snow chains

Safety notes

WARNING

If snow chains are fitted to unsuitable tyres, the snow chains can come into contact with parts of the vehicle. There is a risk of accident or material damage. Only fit snow chains on tyres which have been approved by the manufacturer as being suitable for snow chains.

WARNING

Insufficiently tensioned snow chains can damage tyres and vehicle components. There is a risk of accident or material damage. Ensure that snow chains are always adequately tensioned. Re-tension them if necessary in accordance with the snow chain manufacturer's instructions.

Fine-link snow chains

The vehicle manufacturer recommends using fine-link snow chains. Certain fine-link snow chains have been tested, found safe for use in traffic and rated as suitable by the manufacturer of the vehicle.

Information regarding suitable snow chains is available from a Service Partner of the manufacturer or another qualified Service Partner or a specialist workshop.

Use

Snow chains may only be used in pairs on the front wheels with tyres of the following sizes:

- ▷ 195/65 R 16.
- ▷ 195/55 R 17.
- ▷ 205/55 R 17.

Observe the snow chain manufacturer's instructions.

Do not initialise the runflat indicator RPA with snow chains fitted, as it may give incorrect readings.

Do not reset the Tyre Pressure Monitor TPM with snow chains fitted, as it may give incorrect readings.

When driving with snow chains, briefly activate Dynamic Traction Control DTC briefly if necessary.

Maximum speed with snow chains

When snow chains are fitted, do not exceed 50 km/h, 30 mph.

Wheel change

General

For run-flat tyres or when using a flat tyre kit, it is not always necessary to change a wheel immediately if tyre inflation pressure is lost due to a flat tyre.

If required, the tools for changing wheels are available as optional accessories from a Service Partner of the manufacturer, another qualified Service Partner or a specialist workshop.

Safety notes

DANGER

The jack is only intended for raising the vehicle briefly during a wheel change. Even if the safety measures are complied with, there is a risk of the raised vehicle falling over due to the jack slipping. There is a risk of injury or even death. If the vehicle is raised with the jack, do not lie underneath the vehicle and do not start the engine.

DANGER

Supports such as wooden blocks under the jack can prevent it from achieving its load capacity due to the restricted height. The load capacity of the wooden blocks may be exceeded, causing the vehicle to tip over. There is a risk of injury or even death. Do not place supports under the vehicle jack.

WARNING

The jack, issued by the vehicle manufacturer, is provided in order to perform a wheel change in the event of a breakdown. The jack is not designed for frequent use; for example, changing from summer to winter tyres. Using the jack frequently may cause it to become jammed or damaged. There is a risk of injury and material damage. Only use the jack to change an emergency wheel or a spare wheel when the vehicle gets a flat tyre.

WARNING

On soft, uneven or slippery ground, for example snow, ice, tiles or similar, the jack may slip. There is a danger of injury. Perform the wheel change on a level, firm and non-slip surface if at all possible.

WARNING

The jack is only optimised for raising the vehicle and for use with the jacking points on the vehicle. There is a danger of injury. Do not lift another vehicle or other items with the jack.

WARNING

If the jack has not been guided into the jacking point provided, the vehicle might be damaged when the jack is extended, or the jack could slip. There is a risk of injury or material damage.

When extending, make sure that the jack is guided into the jacking point adjacent to the wheel arch.

⚠ WARNING

A vehicle raised with a jack can fall from the jack if lateral forces are applied. There is a risk of injury and material damage. If the vehicle is raised, do not apply any lateral forces to the vehicle or pull the vehicle with sudden movements. Have any wheel that is jammed removed by a Service Partner of the manufacturer or another qualified Service Partner or a specialist workshop.

⚠ Vehicle jack: Australian/New Zealand standard AS/NZS 2693

2007 – "Vehicle jacks" includes the following warning which the manufacturer of your BMW herewith adopts: "... no person should place any portion of their body under a vehicle that is supported only by a jack".

The jack supplied with your car should not be used for any purpose other than wheel changing and should never be used in conjunction with a vehicle support stand. Raising the vehicle for the purpose of inspection should only be performed in a controlled workshop environment on a hoist by trained personnel.

The following AS/NZS 2693:2007 warnings are repeated here: the jack should be used on level firm ground wherever possible. It is recommended that the wheels of the vehicle be chocked, and that no person should remain in a vehicle that is being jacked.

The jack of your BMW is maintenance-free.

Please observe the information marked on the jack.

Protecting the vehicle against rolling

General

The vehicle manufacturer recommends that the vehicle should additionally be protected against rolling away during a wheel change.

On a level surface



Place chocks or other suitable objects, such as stones, in front of and behind the wheel diagonally opposite to the one being changed.

On a slight downhill slope

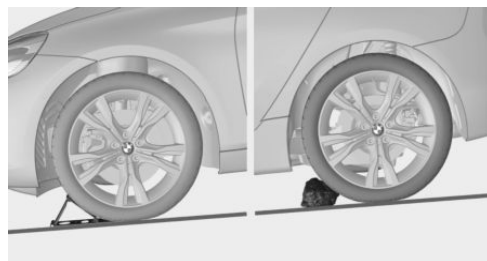

If it is necessary to change a wheel on a slight downhill slope, place chocks and other suitable objects, for example stones, under the wheels of the front and rear axles against the direction of roll.

Locking wheel bolts

Principle

The wheel locking bolts have a special coding. The bolts can only be released with the adapter that matches the coding.

Overview

The adapter of the locking wheel bolts can be found in the on-board tool kit or in an oddments tray in the on-board tool kit.

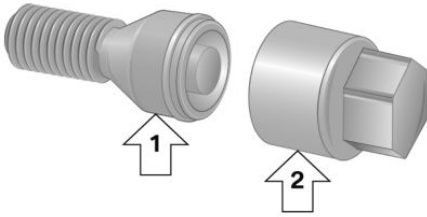

- ▷ Wheel bolt, arrow 1.
- ▷ Adapter, arrow 2.

Unscrewing

1. Place the adapter on the wheel bolt.
2. Unscrew the wheel bolt.
3. After unscrewing the wheel stud, remove the adapter again.

Screwing on

1. Place the adapter on the wheel bolt. If necessary, turn the adapter until it fits on the wheel bolt.
2. Screw on the wheel bolt. The tightening torque is 140 Nm.
3. After screwing on the wheel stud, remove the adapter again and stow it.

Preparing the vehicle

- ▷ Park the vehicle on firm and non-slip ground at a safe distance from traffic.

- ▷ Switch on the hazard warning lights.
- ▷ Apply the parking brake.
- ▷ Engage a gear or select selector lever position P.
- ▷ As soon as the traffic permits, have all vehicle occupants get out of the vehicle and guide them out of the danger area, for example behind the crash barrier.
- ▷ Depending on the equipment, take the wheel change tools and, if necessary, the spare wheel out of the vehicle.
- ▷ If applicable, set up warning triangle or flashing light at the correct distance.
- ▷ Additionally protect the vehicle against rolling away.
- ▷ Undo the wheel bolts by half a turn.

Jacking points

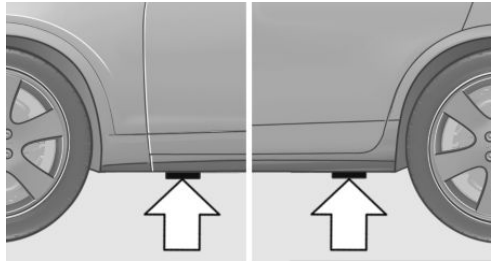

The jacking points are located in the marked positions.

Raising vehicle

⚠ WARNING

Your hands or fingers could get trapped when using the jack. There is a danger of injury. Keep your hands in the described position when using the jack, and do not change this position.

1. Use one hand to secure the jack, arrow 1, and your other hand to grip the jack crank, arrow 2.

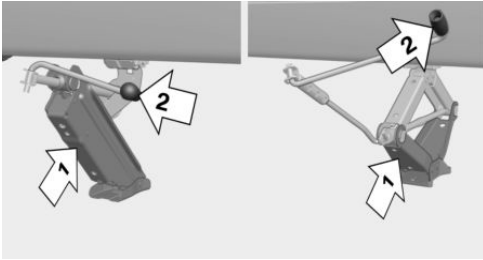

2. Guide the jack into the rectangular recess of the jacking point closest to the wheel to be changed.

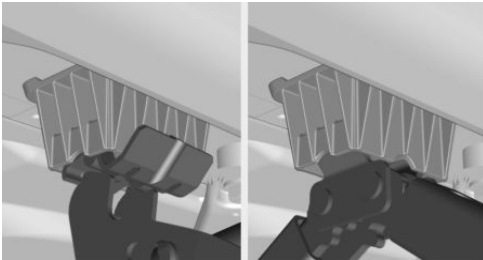

3. Turn the jack crank or lever clockwise to extend the jack.

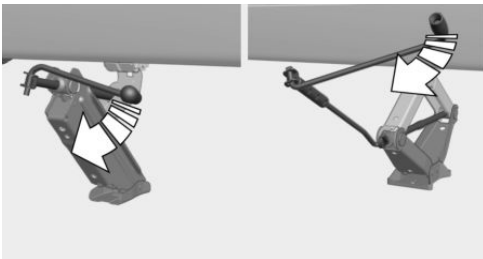

4. Remove your hand from the jack as soon as the jack is under load and continue to turn the jack crank or lever with one hand.

5. Make sure that the base of the vehicle jack is extended vertically and at right angles underneath the jacking point.

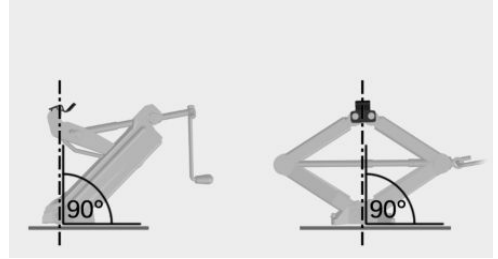

6. Make sure that the base of the jack is vertical and at right angles below the jacking point after extension.

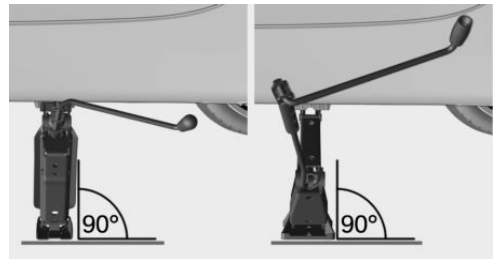

7. Raise by cranking until the jack is supported on the ground with its entire surface and the wheel in question is a maximum of 3 cm, 1.2 inches off the ground.

Fitting a wheel

Only fit one spare wheel at most, as required.

1. Unscrew the wheel studs.
2. Remove the wheel.
3. Put on the new wheel or spare wheel and tighten at least two wheel bolts crosswise until finger-tight.

If non-original light alloy wheels not from the vehicle manufacturer are fitted, the wheel studs belonging to the wheels may also have to be used.

4. Tighten the remaining wheel bolts until finger-tight and then tighten all the wheel bolts crosswise.
5. Turn the jack crank anticlockwise to retract the jack and lower the vehicle.
6. Remove the jack and stow it securely.

After changing the wheel

1. Tighten the wheel bolts crosswise. The tightening torque is 140 Nm, 101 lb ft.
2. Stow the faulty wheel in the luggage compartment, if necessary.

Due to its size, the faulty wheel cannot be accommodated under the luggage compartment floor.

3. Check tyre inflation pressure at the next opportunity and correct as necessary.
4. Reinitialise the runflat indicator RPA.
Reset the Tyre Pressure Monitor TPM.
5. Check the tight fit of the wheel bolts using a calibrated torque wrench.
6. Drive to the nearest Service Partner of the manufacturer or another qualified Service Partner or a specialist workshop to have the damaged tyre replaced.

Not for Australia/New Zealand: Spare wheel

Principle

In case of a flat tyre, the spare wheel can be used as a replacement for the defective tyre. The spare wheel is intended for short-term use until the defective wheel has been replaced.

General

Only fit one spare wheel at most.

Additionally, regularly check the tyre inflation pressure of the spare wheel in the luggage compartment and correct the pressure if necessary.

Safety note

WARNING

The spare wheel has special dimensions. When driving with an spare wheel, the driving properties may change, for example reduced directional stability when braking, longer braking distance and modified self-steering behaviour in the limit range. There is a risk of accident. Drive with care and do not exceed a speed of 80 km/h, 50 mph.

Overview

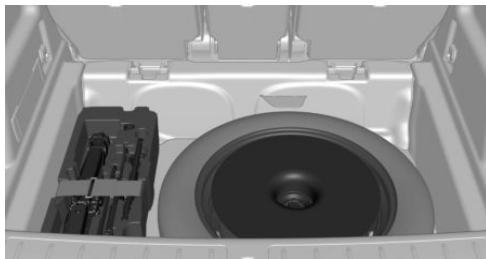

The emergency wheel and the tools for changing wheels are located underneath the luggage compartment floor.

Removing spare wheel

1. Pull up and remove the luggage compartment floor.
2. Undo wing stud.
3. Remove the retaining plate or the cover.
4. Where applicable, remove the bracket and the trailer tow hitch.
5. Remove the vehicle jack and tool holder on the left next to the spare wheel.
6. Push spare wheel to left and remove.

Inserting the spare wheel

1. Insert the spare wheel on the left and slide it to the right.
2. Where applicable, mount the bracket and the trailer tow hitch.
3. Attach the retaining plate or the cover.
4. Screw on and tighten the wing nut.
5. Insert and secure the vehicle jack and tool holder on the left next to the spare wheel.
6. Insert the luggage compartment floor.

Engine compartment

Vehicle equipment

This chapter describes all standard, country-specific and optional equipment available for the model series. It may therefore describe equipment and functions which are not installed in

your vehicle, for example on account of the optional equipment selected or the national-market version. This also applies to safety-relevant functions and systems. Please comply with the relevant laws and regulations when using the corresponding functions and systems.

Overview

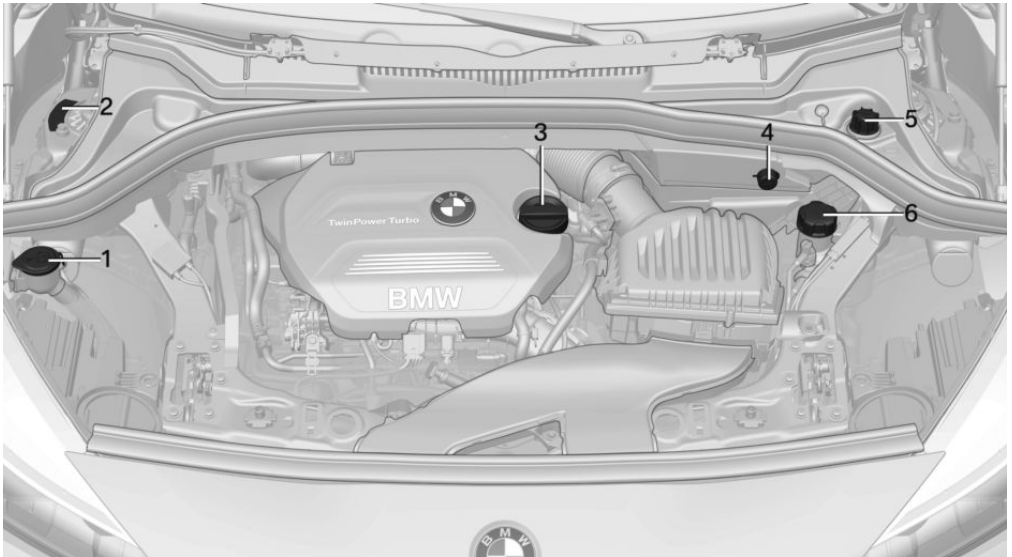

- | | | | |
|---|-------------------------------|---|---|
| 1 | Filler neck for washing fluid | 4 | Starting aid, positive battery terminal |
| 2 | Vehicle identification number | 5 | Starting aid, negative battery terminal |
| 3 | Oil filler neck | 6 | Coolant tank |

Bonnet

Safety notes

⚠ WARNING

Incorrectly performed work in the engine compartment can damage components and poses a safety risk. There is a risk of accident or material damage. Have work in the engine compartment undertaken by a Service Partner of the manufacturer or another qualified Service Partner or a specialist workshop.

⚠ WARNING

The engine compartment contains moving components. Certain components in the engine compartment can also move when the vehicle is switched off, for example the radiator fan. There is a danger of injury. Do not reach into an area where there are moving parts. Keep articles of clothing and hair away from moving parts.

⚠ WARNING

The bonnet has protruding parts on the inside, for example locking hooks. There is a danger of injury. When the bonnet is open, watch out for protruding parts and keep these areas clear.

⚠ WARNING

If the bonnet is not correctly locked, it can come open during the journey and impair visibility. There is a risk of accident. Stop immediately and close the bonnet correctly.

⚠ WARNING

Parts of the body can become trapped when opening and closing the bonnet. There is a danger of injury. When opening and closing, make sure that the area of movement of the bonnet is kept clear.

⚠ NOTE

Wipers which are folded away from the windscreen can become trapped if the bonnet is opened. There is a risk of material damage. Before opening the bonnet, make sure that the wipers are fitted with wiper blades and are in contact with the windscreen.

⚠ NOTE

When closing, the bonnet must lock into place on both sides. Applying additional pressure can damage the bonnet. There is a risk of material damage. Open the bonnet again and close it firmly. Avoid applying additional pressure.

Opening the bonnet

1. Pull the lever, arrow 1.
The bonnet is released.

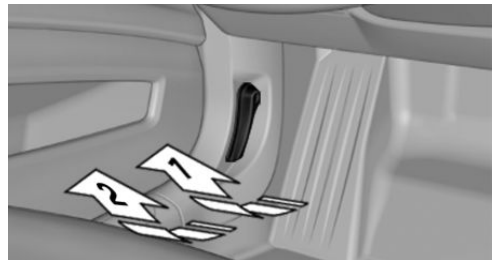

2. After releasing the lever, pull the lever again, arrow 2.
The bonnet is opened.

Indicator and warning lamps

With the bonnet unlocked, a Check Control message is shown.

Closing the bonnet

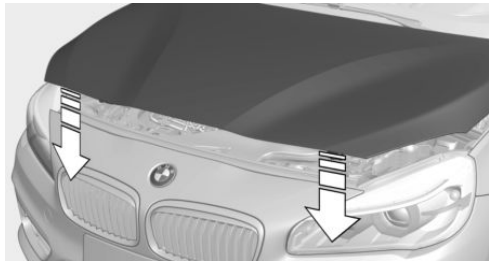

Allow the bonnet to drop from a height of approximately 50 cm, 20 in.

The bonnet must engage on both sides.

Engine oil

Vehicle equipment

This chapter describes all standard, country-specific and optional equipment available for the model series. It may therefore describe equipment and functions which are not installed in your vehicle, for example on account of the optional equipment selected or the national-market version. This also applies to safety-relevant functions and systems. Please comply with the relevant laws and regulations when using the corresponding functions and systems.

General

Engine oil consumption depends on the driving style and operating conditions.

Therefore check the engine oil level regularly each time you fill up with fuel by taking a detailed measurement.

Engine oil consumption may increase due to the following, for example:

- ▶ Dynamic driving style.
- ▶ While running in the engine.
- ▶ Engine idling.
- ▶ Use of engine oil grades rated as unsuitable.

Different Check Control messages are shown on the control display, depending on the engine oil level.

Safety notes

NOTE

Too little engine oil causes engine damage. There is a risk of material damage. Top up with engine oil immediately.

NOTE

Too much engine oil can damage the engine or the catalytic converter. There is a risk of material damage. Do not add too much engine oil. If there is too much engine oil, have the engine oil level corrected by a Service Partner of the manufacturer or another qualified Service Partner or a specialist workshop.

Electronic oil measurement

General

Electronic oil measurement uses two measuring procedures:

- ▶ Monitoring.
- ▶ Detailed measurement.

When frequently making short trips or using a dynamic driving style, for example taking corners at high speed, perform a detailed measurement at regular intervals.

Monitoring

Principle

The engine oil level is monitored electronically during the journey and can be shown on the control display.

If the engine oil level is outside its permissible operating range, a Check Control message is shown.

Operating requirements

A current reading is available after approximately 30 minutes of normal driving.

Displaying the engine oil level

Via iDrive:

1. "My Vehicle"
2. "Vehicle status"
3.  "Engine oil level"

The engine oil level is displayed.

System limits

When frequently making short trips or using a dynamic driving style, it may not be possible to measure the oil level. In this case, the measurement for the last, sufficiently long journey is displayed.

Detailed measurement

Principle

The engine oil level is checked when the vehicle is stationary and is shown on a scale.

If the engine oil level is outside its permissible operating range, a Check Control message is shown.

General

During measurement, the idle speed is increased slightly.

Operating requirements

- ▷ Vehicle is standing on level ground.
- ▷ Manual transmission: gear lever in neutral position, clutch and accelerator pedal not pressed.
- ▷ Steptronic transmission: selector lever in selector lever position N or P and accelerator pedal not pressed.
- ▷ Engine is running and is at operating temperature.

Carrying out a detailed measurement

Via iDrive:

1. "My Vehicle"
2. "Vehicle status"

3.  "Engine oil level"
4. "Measure engine oil level"
5. "Start measurement"

The engine oil level is checked and shown on a scale.

Adding engine oil

General

Do not top up engine oil unless a message is displayed in the instrument cluster. The top-up amount is specified in the message on the instrument cluster.

Only top up with suitable engine oil grades.

Safely park the vehicle and switch off the ignition before replenishing the engine oil.

Do not add too much engine oil.

Safety notes

WARNING

Operating fluids, for example oils, greases, coolants and fuels, can contain substances that are harmful to health. There is a risk of injury or even death. Please comply with the instructions on the containers. Do not allow operating fluids to come into contact with clothing, skin or eyes. Do not pour operating fluids into other bottles. Keep operating fluids out of the reach of children.

NOTE

Too little engine oil causes engine damage. There is a risk of material damage. Top up with engine oil immediately.

NOTE

Too much engine oil can damage the engine or the catalytic converter. There is a risk of material damage. Do not add too much engine oil. If there is too much engine oil, have the engine oil level corrected by a Service Partner of the manufacturer or another qualified Service Partner or a specialist workshop.

Overview

The oil filler neck is in the engine compartment, see page 278.

Adding engine oil

1. Open the bonnet, see page 279.
2. Turn the cap anticlockwise to open.

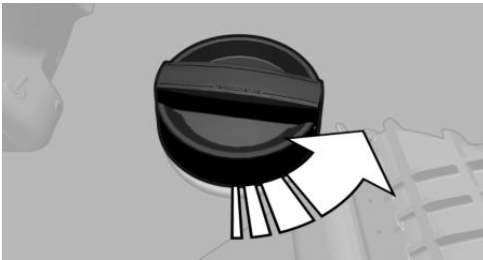

3. Add engine oil.
4. Tighten cap.

Engine oil grades for topping up**General**

Engine oil quality is a critical factor in the service life of the engine.

Only top up with the types of engine oil that are listed.

Some engine oil grades may not be available in all countries.

Safety notes**NOTE**

Oil additives can damage the engine. There is a risk of material damage. Do not use oil additives.

NOTE

Using the wrong engine oil can result in engine malfunctions and damage. There is a risk of material damage. When selecting the engine oil, make sure that it is the correct specification.

Suitable engine oil grades

Engine oils with the following oil specifications can be used.

Petrol engine

BMW Longlife-04.

BMW Longlife-12 FE.

BMW Longlife-17 FE+.

Diesel engine

BMW Longlife-04.

BMW Longlife-12 FE.

The oil specification BMW Longlife-12 FE is not suitable for the 25d diesel engine.

Alternative engine oil grades

If suitable engine oils are not available, up to 1 litre, 2 pints, of an engine oil with the following oil specification can be used for topping up:

Petrol engine

ACEA C2.

ACEA C3.

Diesel engine

ACEA C2.

ACEA C3.

Viscosity classes

When selecting an engine oil, make sure that the engine oil belongs to one of the following viscosity classes:

Viscosity classes

SAE 0W-20.

SAE 5W-20.

SAE 0W-30.

SAE 5W-30.

SAE 0W-40.

SAE 5W-40.

Viscosity classes SAE 0W-20 and SAE 5W-20 are not suitable for diesel engines.

Viscosity classes with a high viscosity grade can increase fuel consumption.

Further information on suitable engine oil specifications and viscosity classes can be obtained from a Service Partner of the manufacturer or another qualified Service Partner or a specialist workshop.

ner of the manufacturer or another qualified Service Partner or a specialist workshop.

**BMW recommends
Original BMW Engine Oil.**

Oil change** NOTE**

If the engine oil is not changed at the correct time, engine wear may increase which could cause engine damage. There is a risk of material damage. Do not exceed the service date indicated in the vehicle.

The manufacturer of the vehicle recommends having the engine oil changed by a Service Part-

Coolant

Vehicle equipment

This chapter describes all standard, country-specific and optional equipment available for the model series. It may therefore describe equipment and functions which are not installed in your vehicle, for example on account of the optional equipment selected or the national-market version. This also applies to safety-relevant functions and systems. Please comply with the relevant laws and regulations when using the corresponding functions and systems.

General

Coolant is a mixture of water and an additive.

Not all commercially available additives are suitable for the vehicle. Do not mix additives of different colours. Comply with the 50:50 mixing ratio of water to additive. Information regarding suitable additives is available from a Service Partner of the manufacturer or another qualified Service Partner or a specialist workshop.

Safety notes

⚠ WARNING

If the cooling system is opened when the engine is hot, coolant can escape and cause scalding. There is a danger of injury. Only open the cooling system when the engine has cooled down.

⚠ WARNING

Additives are harmful to health and using the wrong additives can damage the engine. There is a risk of injury and material damage. Do not allow additives to come into contact with clothing, skin or eyes, and do not swallow them. Only use suitable additives.

Coolant level

Checking

In the coolant tank there are yellow Min and Max markings.

1. Allow the engine to cool down.
2. Open the bonnet.
3. Turn cap on coolant tank slightly anticlockwise, then allow the pressure to escape.

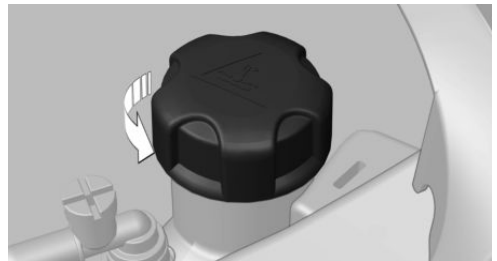

4. Open cap on coolant tank.
5. The coolant level is correct if it is between the Min. and Max. marks in the filler neck.
6. Tighten cap.

Topping up the coolant

1. Allow the engine to cool down.
2. Open the bonnet.

3. Turn the cap on the coolant tank slightly anti-clockwise until it starts to open, then allow the pressure to escape before opening it fully.

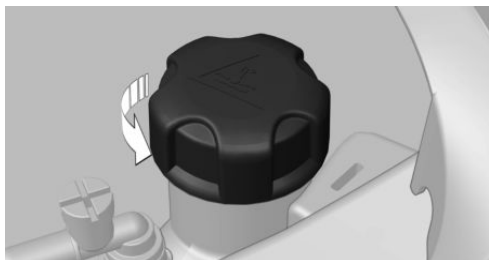

4. If necessary, slowly top up to the correct level; do not overfill.
5. Tighten cap.
6. Have the cause of coolant loss rectified as soon as possible.

Disposal



When disposing of coolant and coolant additives, comply with the relevant environmental protection regulations.

Maintenance

Vehicle equipment

This chapter describes all standard, country-specific and optional equipment available for the model series. It may therefore describe equipment and functions which are not installed in your vehicle, for example on account of the optional equipment selected or the national-market version. This also applies to safety-relevant functions and systems. Please comply with the relevant laws and regulations when using the corresponding functions and systems.

BMW Maintenance System

The maintenance system indicates what maintenance measures are required and thereby assists in maintaining the road safety and operational safety of the vehicle.

The exact work required and the maintenance intervals may vary depending on the national-market version. Labour, spare parts, operating materials and wear materials are charged separately. Additional information is available from a Service Partner of the manufacturer or another qualified Service Partner or a specialist workshop.

Condition Based Service CBS

Principle

Sensors and special algorithms monitor the conditions in which the vehicle is used. CBS uses this information to determine what maintenance is required.

The system therefore allows the scope of the maintenance work to be adapted to the individual usage profile.

General

Information on service requirements, see page 134, can be shown on the control display.

Service data in the vehicle key

Information on maintenance requirements is continuously stored in the vehicle key. The Service Partner can read out this data and suggest a programme of maintenance for your vehicle.

It is therefore important to give the service advisor the vehicle key that was last used to drive the vehicle.

Periods out of use

Periods when the vehicle is out of use with its battery disconnected are not taken into account.

In such cases, have any time-dependent maintenance procedures, for example those concerning the brake fluid and, where applicable, the engine oil and microfilter/active carbon filter, updated by a Service Partner of the manufacturer or another qualified Service Partner or a specialist workshop.

Service history

Maintenance and repairs

Have maintenance and repairs carried out by a Service Partner of the manufacturer or another qualified Service Partner or a specialist workshop.

Entries

The maintenance work carried out is entered in the maintenance records and the vehicle data. As with a service booklet, the entries provide evidence of regular maintenance.

If an entry is made in the electronic service history of the vehicle, service-relevant data is saved

both in the vehicle and in the central IT systems of BMW AG, Munich.

After a change of vehicle ownership, the new owner will be able to view the data entered in the electronic service history. Similarly, a Service Partner of the manufacturer or another qualified Service Partner or a specialist workshop can also view the data entered in the electronic service history.

Objection

The vehicle owner is entitled to contact a Service Partner of the manufacturer or another qualified Service Partner or a specialist workshop to lodge an objection to entries being made in the electronic service history and to the associated storage in the vehicle and subsequent transfer to the vehicle manufacturer of any data relating to his/her time as the vehicle owner. In such cases, no entries will be made in the vehicle's electronic service history.

Displays

The logged maintenance work can be displayed via the service history, see page 135, on the control display.

For Australia/New Zealand: maintenance

No maintenance work other than normal maintenance is required to keep the emission levels of your vehicle within the design limits.

Socket for on-board diagnosis OBD

General

Devices connected to the OBD socket trigger the alarm system when the vehicle is locked. Remove any devices connected to the OBD socket before locking the vehicle.

Safety note

⚠ NOTE

Incorrect use of the OBD on-board diagnosis socket can cause malfunctions in the vehicle. There is a risk of material damage. Only have service and maintenance work involving the OBD on-board diagnosis socket carried out by a Service Partner of the manufacturer or another qualified Service Partner or a specialist workshop or other authorised persons. Only connect devices that have been tested and found to be safe for use with the OBD on-board diagnosis socket.

Position

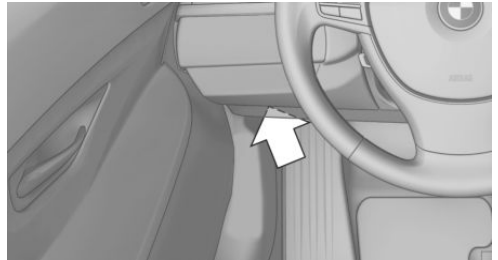

The OBD socket for checking emissions-relevant components is located on the driver's side.

Engine warning light



- ▶ When warning light flashes:
May have engine failure that may cause damage to the catalyst device. Please check with your dealer immediately.
- ▶ When warning light illuminates:
High exhaust gas value. Please check with your dealer.

Vehicle recycling

The manufacturer of the vehicle recommends returning the vehicle to a collection point nominated by the manufacturer at the end of its life cycle. The regulations concerning the returning of end-of-life vehicles may vary from country to country. Additional information is available from a Service Partner of the manufacturer or another qualified Service Partner or a specialist workshop.

Replacing parts

Vehicle equipment

This chapter describes all standard, country-specific and optional equipment available for the model series. It may therefore describe equipment and functions which are not installed in your vehicle, for example on account of the optional equipment selected or the national-market version. This also applies to safety-relevant functions and systems. Please comply with the relevant laws and regulations when using the corresponding functions and systems.

On-board tool kit

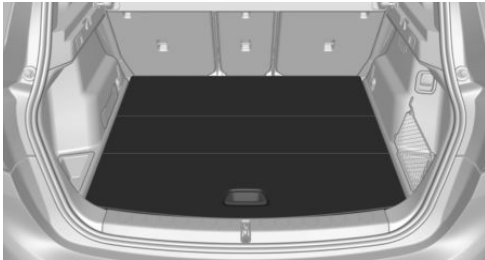

The on-board tool kit is located under the luggage compartment floor.

Wiper blades

Safety notes

NOTE

The windscreen may sustain damage if a wiper falls onto it without the wiper blade fitted. There is a risk of material damage. Hold the wiper firmly when changing the wiper blade. Do not fold in or switch on the wiper without a wiper blade installed.

NOTE

Wipers which are folded away from the windscreen can become trapped if the bonnet is opened. There is a risk of material damage. Before opening the bonnet, make sure that the wipers are fitted with wiper blades and are in contact with the windscreen.

Replacing the front wiper blades

1. To replace the wiper blade, move the wiper to the fold-out position, see page 117.
2. Fold out the wiper arm and hold firm.
3. Press the button, arrow 1, and pull out wiper blade.

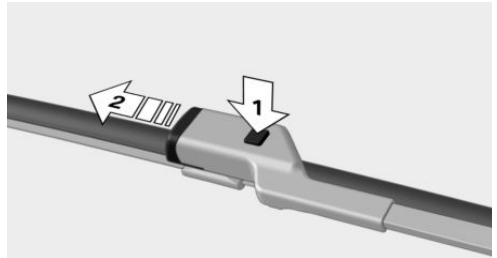

4. Insert the new wiper blade in the opposite sequence ensuring that it clips into place.
5. Fold in the wipers.

Replacing the rear wiper blade

1. To replace the wiper blade, move the wiper to the fold-out position, see page 117.
2. Fold out wiper arm.

3. Rotate wiper blade backwards up to the stop.

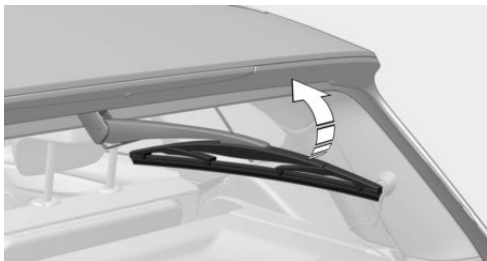

4. Continue to rotate wiper blade against the stop to push it out of its fastening.
5. Press new wiper blade into the fastening until you hear it engaging.
6. Fold in the wipers.

Replacing lights and bulbs

General

Bulbs and lights

Lights and bulbs are an important aspect of driving safety.

The manufacturer of the vehicle recommends having the corresponding work carried out by a Service Partner of the manufacturer or another qualified Service Partner or a specialist workshop.

A box of spare bulbs is available from a Service Partner of the manufacturer or another qualified Service Partner or a specialist workshop.

Comply with the safety notes, see page 291.

Light-emitting diodes, LEDs

Some equipment versions have light-emitting diodes behind a cover as a light source. These light-emitting diodes are similar to conventional lasers and are classified by legislation as Class 1 light-emitting diodes.

Comply with the safety notes, see page 291.

Safety notes

Bulbs and lights

⚠ WARNING

Bulbs can become hot during operation. Contact with the bulbs can lead to burns. There is a danger of injury. Only replace bulbs when they have cooled down.

⚠ WARNING

Short circuits can occur when working on lighting systems that are switched on. There is a risk of injury or material damage. Switch the respective lights off when working on the lighting system. Where applicable, observe the enclosed instructions from the bulb manufacturer.

⚠ NOTE

Dirty bulbs have a reduced lifetime. There is a risk of material damage. Do not touch the glass of new bulbs with your bare hands. Use a clean tissue or similar, or hold the bulb by its base.

Light-emitting diodes, LEDs

⚠ WARNING

Intense brightness can irritate or harm the retina of the eye. There is a danger of injury. Do not look directly into the headlights or other light sources. Do not remove covers from LEDs.

Headlight glass

During cool or humid weather, the headlight glass can mist over on the inside. When driving with the lights switched on, the condensation disappears after a short time. There is no need to replace the headlight glass.

If moisture increases, for example if there are water droplets in the lamp despite the headlights being switched on, have the headlights checked.

Headlight adjustment

Changing bulbs and lights may affect the settings for the headlights. Have the headlight adjustment checked and if necessary corrected by a Service Partner of the manufacturer or another qualified Service Partner or a specialist workshop.

Front lights, replacing the lamps

Halogen headlights

Overview

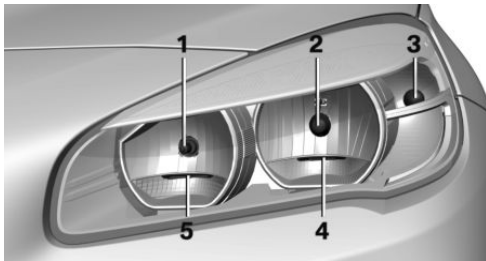

- 1 High-beam headlights, headlight flasher
- 2 Low-beam headlights
- 3 Turn indicator
- 4 Side lights/daytime running lights
- 5 Side lights/daytime running lights

Side lights, daytime running lights

The side lights and daytime running lights use LED technology.

In the event of a fault, contact a Service Partner of the manufacturer or another qualified Service Partner or a specialist workshop.

Access to turn indicators, low-beam headlights, high-beam headlights/headlight flasher

Comply with the safety notes, see page 291.

Open the bonnet, see page 279.

Turn indicator

Bulb type PY21W, 21 watt.

1. Turn the bulb holder anticlockwise and remove.

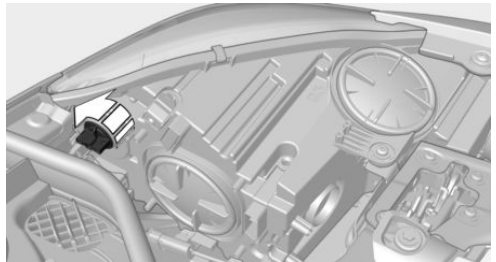

2. Press the bulb gently into the fitting, turn anticlockwise and remove.
3. Fit new bulb and bulb holder in the reverse sequence.

Low-beam headlights

H7LL bulb, 55 watt.

1. Turn the cover anticlockwise and remove.

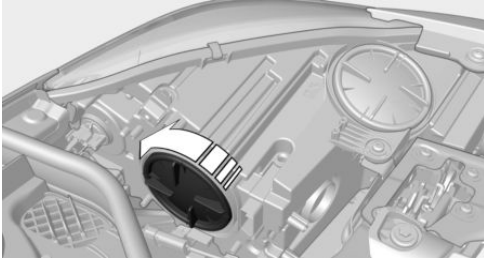

2. Pull bulb holder off straight backwards, arrow 1, and remove.

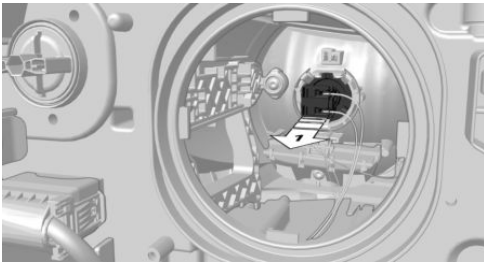

3. Remove bulb from the bulb holder.
4. Fit new bulb with bulb holder in the reverse sequence.

When doing this, position the lug of the bulb correctly in the headlight housing and feel the bulb holder engage.

5. Close the headlight housing with the lid. Ensure that the lid engages.

High-beam headlights/headlight flasher

Bulb type 55 watt, H7.

1. Turn the cover anticlockwise and remove.

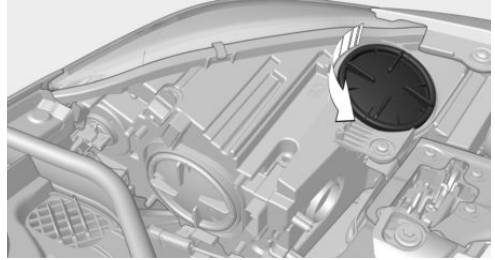

2. Pull bulb holder off straight backwards, arrow 1, and remove.

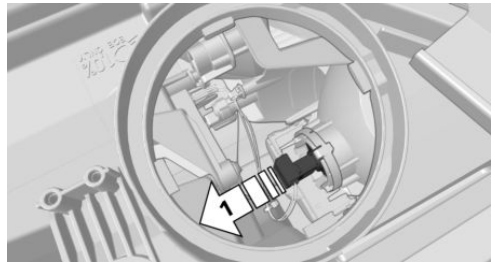

3. Remove bulb from the bulb holder.
4. Fit new bulb with bulb holder in the reverse sequence.

When doing this, position the lug of the bulb correctly in the headlight housing and feel the bulb holder engage.

5. Close the headlight housing with the lid. Ensure that the lid engages.

LED headlights

Overview

Front lights

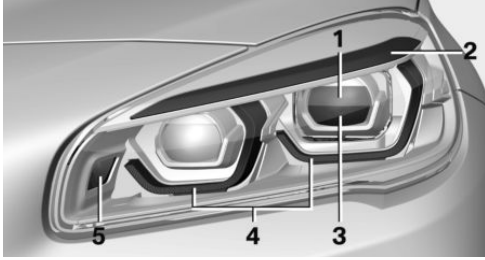

- 1 High-beam headlights, headlight flasher
- 2 Turn indicator
- 3 Low-beam headlights
- 4 Side lights/daytime running lights
- 5 Depending on the equipment: cornering light

Front lights

The following lights are designed in LED technology:

- ▶ High-beam headlights
- ▶ Side lights/daytime running lights
- ▶ Low-beam headlights
- ▶ Cornering light
- ▶ Turn indicator

In the event of a fault, contact a Service Partner of the manufacturer or another qualified Service Partner or a specialist workshop.

LED fog light

Comply with the safety notes, see page 291.

The LED fog lights use LED technology.

In the event of a fault, contact a Service Partner of the manufacturer or another qualified Service Partner or a specialist workshop.

Turn indicator in exterior mirror

The turn indicators in the exterior mirrors use LED technology. In the event of a fault, contact a Service Partner of the manufacturer or another qualified Service Partner or a specialist workshop.

Rear lights, replacing the bulbs

Vehicles with halogen headlights

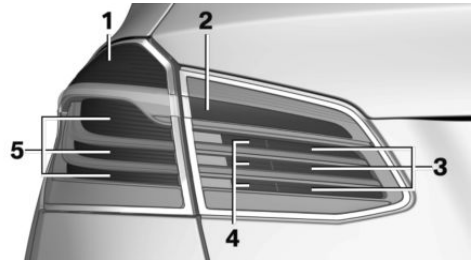

- 1 Turn indicators
- 2 Reversing light
- 3 Rear fog light/rear light
- 4 Rear light
- 5 Brake light/rear light

Replacing the lamps of outer rear lights

General

Comply with the safety notes, see page 291.

Turn indicator: bulb type P21WLL, 21 watt.

Brake light: bulb type P21WLL, 21 watt.

Removing the outer rear light

1. Opening of the tailgate.
2. Remove cover. Cover is attached with three plug connections, arrow 2.

To remove, place the screwdriver from the on-board tool kit between the cover and body, arrow 1. Make sure that the paint is not damaged.

Pry cover out of plug connections and remove, arrow 3.

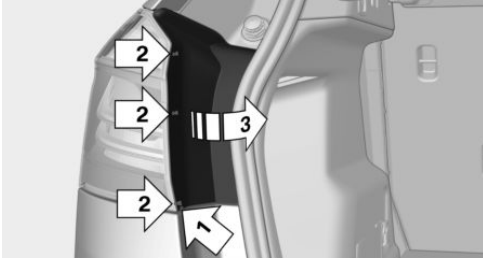

3. Unscrew both nuts, arrows 1, of outer rear light. To unscrew, it is possible to use the handle of the screwdriver from the on-board tool kit.

Carefully remove rear light forwards from body, arrow 2. Make sure that cables are not damaged.

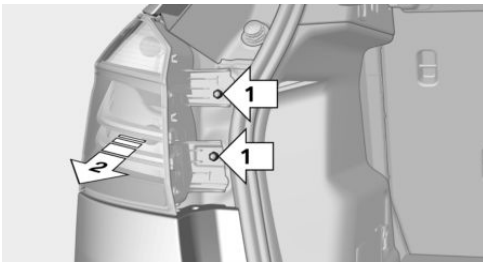

4. Pull plug off bulb holder by disconnecting cables from rear light.

Replacing the bulbs

1. Unscrew the three fastenings, arrows 1, on bulb holder. Remove bulb holder from rear light, arrow 2.

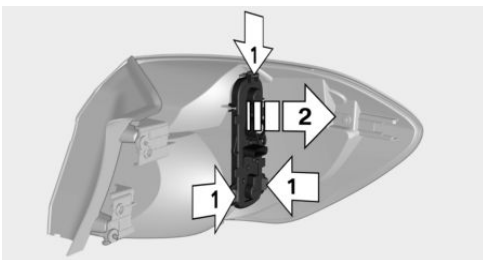

2. Press the faulty bulb gently into the fitting, turn anticlockwise and remove.
 - ▷ Upper bulb: turn indicator
 - ▷ Lower bulb: brake light
3. To insert the new bulb and attach the bulb holder, proceed in the opposite sequence. Ensure that the bulb holder engages in all fastenings.

Installing rear light

1. Connect plug and fit cables to the rear light.
2. Position rear light with lug on the mounting point on the body and push onto both threaded pins.

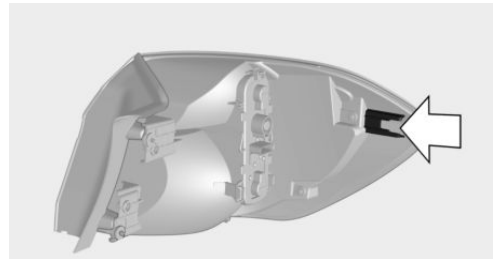

3. Press on rear light flush and tighten both nuts.
4. Install cover. Make sure that the plastic tabs of the cover are correctly seated in the corresponding recesses of the body.

Lights in the tailgate

Vehicles with halogen headlights

Comply with the safety notes, see page 291.

Reversing light: bulb type P21WLL, 21 watts

Rear fog light: bulb 21 watts, H21WLL

Rear light: bulb type P21WLL, 5 watts

Access to the lights

1. Opening of the tailgate.

- Pull out cover on handle recess.



- Remove the plug from the bulb holder.

Changing the reversing light, rear fog light and rear light

- Undo the fastenings, arrows 1, on bulb holder.
Remove bulb holder from rear light, arrow 2.

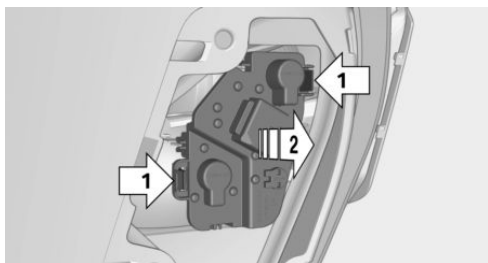

- Press the faulty bulb gently into the fitting, turn anticlockwise and remove.

- ▶ Upper bulb: reversing light
- ▶ Lower bulb: rear fog light

Only vehicles with halogen headlights:

- ▶ Lower bulb, 5 watts: rear light

Installing lamp holder

- To insert the new bulb and attach the bulb holder, proceed in the opposite sequence.
Connect plug to bulb holder.
- Make sure bulb holder is seated correctly and firmly.

Centre brake light and number plate lights

Comply with the safety notes, see page 291.

These lights use LED technology. In the event of a fault, contact a Service Partner of the manufacturer or another qualified Service Partner or a specialist workshop.

Vehicle battery

General

The battery is maintenance-free.

More information regarding the battery can be obtained from a Service Partner of the manufacturer or another qualified Service Partner or a specialist workshop.

Safety notes

⚠ DANGER

Touching live components can result in an electric shock. There is a risk of injury or even death. Do not touch any components that could be live.

⚠ WARNING

Vehicle batteries that are classified as unsuitable may damage systems or result in functions no longer being carried out. There is a risk of injury or material damage. Only use vehicle batteries that have been classified as suitable by the vehicle manufacturer.

Registering the battery with the vehicle

The manufacturer of the vehicle recommends having a Service Partner of the manufacturer or another qualified Service Partner or an authorised workshop register the vehicle battery with the vehicle after the battery has been replaced.

Once the battery has been registered again, all comfort functions will be available without restriction and any Check Control messages relating to the comfort functions will no longer be displayed.

Hazard symbols

The following hazard symbols can be found on the vehicle battery:

Symbol	Meaning
	No smoking, no naked flames, no sparks.
	Wear protective goggles.
	Keep away from children.
	Risk of acid burns: wear gloves, do not tilt the battery.
	Rinse any splashes of acid with water immediately. If acid comes into contact with eyes or is swallowed, seek medical attention immediately.
	No direct sunlight, no frost.
	Follow the user manual.
	Explosive gas mixture. Do not seal any openings on the battery.

Replacing the battery

General

The manufacturer of the vehicle recommends only having the vehicle battery replaced by a Service Partner of the manufacturer or another

qualified Service Partner or an authorised workshop. If the battery is not replaced correctly, the vehicle may not recognise it properly and perfect functioning cannot be guaranteed.

Notes on removal

Observe the following notes on removing the vehicle battery:

- ▷ Park the vehicle and switch off consumers.
- ▷ First disconnect the power at the negative terminal. Then disconnect the power at the positive terminal.

Notes on installation

Observe the following notes on installing the vehicle battery:

- ▷ Remove any foreign bodies from the battery holder.
- ▷ Only install the battery in the intended position in the vehicle.
- ▷ Keep the battery and vehicle connection contacts clean.
- ▷ First connect the power at the positive terminal. Then connect the power at the negative terminal.
- ▷ Use the connections, connectors and covers provided.
- ▷ Connect a hose to the gas outlet opening if necessary.

Initial operation

The battery is operational. No special precautions are required for start-up.

Charging the battery

General

Ensure the battery is sufficiently charged to guarantee the entire lifetime of the battery.

Charge the battery under the following situations:

- ▷ If the inspection glass on the top of the battery is black.

- ▷ If there is insufficient starting power.

The following conditions can have a negative effect on battery performance:

- ▷ Frequently driving short distances.
- ▷ If the vehicle is not used for a period of one month or longer.

Safety note

NOTE

Battery chargers for the vehicle battery may operate with high voltages and high currents which can overload or damage the 12-volt on-board network. There is a risk of material damage. Only connect battery chargers for the vehicle battery to the starting aid terminals in the engine compartment.

Battery charger

Battery chargers developed especially for the vehicle and suitable for the on-board network can be obtained from a Service Partner of the manufacturer or another qualified Service Partner or a specialist workshop.

Charging the battery

Only charge the battery via the starting aid terminals, see page 303, in the engine compartment and with the engine switched off.

Power failure

Following an electrical power failure, some equipment will have to be reinitialised or individual settings will need to be updated, for example:

- ▷ Memory function: save positions again.
- ▷ Time: update.
- ▷ Date: update.
- ▷ Glass sunroof: initialise system.

Storing the battery

Observe the following information on storing vehicle batteries:

- ▷ Store the battery in a cool and dry place.
- ▷ Protect the battery from direct sunlight and frost.
- ▷ Only clean the battery with a damp, anti-static cloth.
- ▷ Store the battery upright and secure it against falling over.
- ▷ Install the oldest batteries first.
- ▷ Do not remove the protective cap from the contacts.
- ▷ Charge or install the battery by the date on the battery label at the latest. Once fully charged, the battery will work for another 10 months.

Disposing of the old battery



Dispose of old batteries at a Service Partner of the manufacturer or another qualified Service Partner or a specialist workshop or hand them in to an authorised collecting point.

Batteries filled with acid should be transported upright. Protect batteries against falling over when in transit.

Warranty

See the vehicle purchase contract for information on the battery warranty.

Fuses

Safety note

WARNING

Incorrect or repaired fuses can overload electrical cables and components. There is a risk of fire. Do not repair blown fuses or replace them with fuses with a different colour or amp rating.

Accessing the fuses

The fuses are located in glove compartment.

1. Open the glove compartment.
2. Pivot the flap down, see arrow.

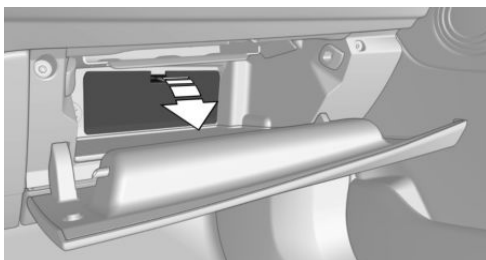

Information on the fuse assignments, as well as the positions of any other fuse boxes, is available on the Internet: www.bmw.com/fusecard.

Where applicable, information on the fuse assignments is also found on a separate sheet in the fuse box.

Replacing fuses

The vehicle manufacturer recommends having fuses changed by a Service Partner of the manufacturer or another qualified Service Partner or a specialist workshop.

Help in case of a breakdown

Vehicle equipment

This chapter describes all standard, country-specific and optional equipment available for the model series. It may therefore describe equipment and functions which are not installed in your vehicle, for example on account of the optional equipment selected or the national-market version. This also applies to safety-relevant functions and systems. Please comply with the relevant laws and regulations when using the corresponding functions and systems.

Hazard warning lights

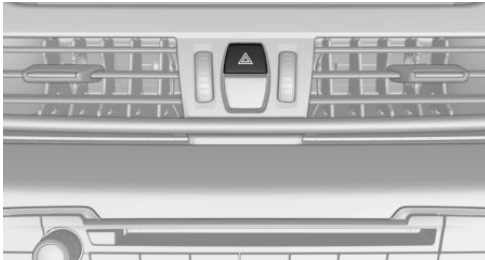

The button is located in the centre console.

Warning triangle



The warning triangle is to be stored on the inside of the tailgate.

To remove it, slide the warning triangle to the side.

First-aid kit

General

Some items in the kit have a limited life.

Check the use-by dates of the contents regularly and replace any items that have expired in good time.

Storage

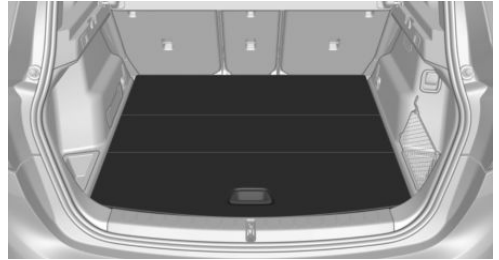

The first-aid kit is to be stored in the luggage compartment, possibly under the luggage compartment floor.

BMW Roadside Assistance

Principle

BMW Group Roadside Assistance can be contacted if you require help in the event of a breakdown.

General

In the event of a breakdown, data on the vehicle condition is transferred to the manufacturer of the vehicle. It is possible that malfunctions can be remedied directly.

There are various ways of making contact.

- ▶ Via a Check Control message, see page 132.
- ▶ Calling with a mobile phone.
- ▶ Via the BMW Connected app.

Depending on the national-market version and vehicle type, a different Roadside Assistance provider can be assigned via the ConnectedDrive customer portal if necessary.

Requirements

- ▶ Activated ConnectedDrive contract, equipment with intelligent emergency call or BMW ConnectedDrive services.
- ▶ Mobile reception.
- ▶ The ignition is switched on.

Starting

When equipped with Teleservices, support is provided first through Teleservice Diagnosis and then by Teleservice Assistance if required.

Via iDrive:

1. "ConnectedDrive"
2. "BMW Assistance"
3. "BMW Roadside Assistance"

Contact with the manufacturer's Roadside Assistance is established.

A telephone number may be displayed. Select it to dial the telephone number using a connected mobile telephone.

Teleservice Diagnosis

Teleservice Diagnosis enables the detailed vehicle data required for diagnosis to be transferred via mobile communications. This data is transferred automatically.

Teleservice Assistance

Teleservice Assistance is a country-specific feature that enables a more in-depth diagnosis of the vehicle via mobile telephony.

Teleservice Assistance can be started after a request by the service specialist.

1. Park the vehicle safely.
2. Apply the parking brake.
3. Control display is switched on.
4. Confirm Teleservice Assistance.

Certain vehicle functions may be restored to a drivable condition.

If this is not possible, further measures will be initiated, for example Mobile Service will be informed.

Emergency call

Intelligent emergency call

Principle

The system can be used to trigger an emergency call automatically or manually in emergency situations.

General

Press the SOS button in an emergency only.

Intelligent emergency call establishes a connection with the BMW emergency call centre.

Even if no emergency call is possible through the BMW intelligent emergency call system, an emergency call will still be placed with a public rescue coordination centre. This depends on factors such as the specific mobile telephone network and national regulations.

For technical reasons, it might not be possible to make an emergency call in highly adverse conditions.

Overview



SOS button in the headliner.

Operating requirements

- ▷ Emergency call system is functional.
- ▷ The ignition is switched on.
- ▷ If the vehicle is equipped with intelligent emergency call: the SIM card integrated in the vehicle is activated.

Automatic triggering

In certain circumstances, for example deployment of the airbags, an emergency call may be placed automatically immediately after an accident of appropriate severity. An automatic emergency call is not affected by pressing the SOS button.

Manual triggering

1. Tap on cover flap.
 2. Press and hold the SOS button until the LED on the button is illuminated green.
- ▷ The LED is illuminated green when the emergency call is activated.
- If a cancellation query is shown on the control display, the emergency call can be cancelled. If the situation permits, wait in the vehicle until voice contact has been established.
- ▷ The LED flashes green when the connection to the emergency number has been established.

When an emergency call is made via BMW, data, for example the vehicle's position if this

can be determined, is sent to the public emergency call centre in order to decide what rescue measures are required. If questions asked by the emergency call centre remain unanswered, rescue measures are implemented automatically.

If you can no longer hear the emergency call centre through the loudspeakers, the hands-free system may be faulty. However, the emergency call centre may still be able to hear you speak.

The emergency call centre ends the emergency call.

Fire extinguisher

Principle

The fire extinguisher can be used to put out vehicle fires.

General

Depending on the vehicle's equipment and the national-market version, the vehicle may have a fire extinguisher.

Overview

The fire extinguisher is located in the interior, for example under the seat or in the glove compartment.

Safety note

WARNING

Incorrect use of the fire extinguisher can cause injury. There is a danger of injury. Observe the information below when using the fire extinguisher:

- ▷ Do not inhale the extinguishing agent. If the extinguishing agent is inhaled, move the casualty out into the fresh air. If the casualty experiences breathing difficulties, contact a doctor immediately.

- ▷ Do not allow the extinguishing agent to come into contact with the skin. Prolonged contact with the extinguishing agent can cause the skin to dry out.
- ▷ Do not allow the extinguishing agent to come into contact with the eyes. In the event of contact with the eyes, rinse them immediately with plenty of water. In case of prolonged discomfort, contact a doctor.

Removing the fire extinguisher

Open the buckles on the retaining strap.

Using the fire extinguisher

To use the fire extinguisher, follow the manufacturer's instructions on the fire extinguisher and the information supplied with it.

Stowing the fire extinguisher

1. Insert the fire extinguisher into the holder.
2. Hook in and close the buckles.

Maintenance and refilling

Have the fire extinguisher checked every 2 years by a Service Partner of the manufacturer or another qualified Service Partner or a specialist workshop.

Make a note of the next maintenance date for the fire extinguisher.

Replace the fire extinguisher after use or have it refilled.

Starting aid

General

If the vehicle battery is discharged, the engine can be started from another vehicle's battery using two jump leads. Only use jump leads with fully insulated terminal clamps.

Safety notes

DANGER

Touching live components can result in an electric shock. There is a risk of injury or even death. Do not touch any components that could be live.

WARNING

Connecting the jump leads in the wrong sequence can cause sparks. There is a danger of injury. Please comply with the correct sequence when connecting.

NOTE

Contact between the bodywork of the two vehicles can result in a short circuit during starting aid. There is a risk of material damage. Make sure there is no contact between the bodywork.

Preparations

1. Check whether the battery in the other vehicle shows 12 volts. Information about the voltage is provided on the battery.
2. Switch off the engine of the other vehicle.
3. Switch off any power consumers in both vehicles.

Starting aid terminals

The starting aid terminal in the engine compartment, see page 278, serves as the positive battery terminal.

Open the cover of the jump-starting connection. A special connection on the body serves as the negative battery terminal in the engine compartment, see page 278.

Connecting the cables

Do not deviate from the procedure described below, otherwise personal injury could result or both vehicles could be damaged.

1. Open the covers of the BMW starting aid terminals.
2. Connect a terminal clamp on the positive/+ jump lead to the positive terminal of the battery or the corresponding starting aid terminal on the other vehicle.
3. Connect the second terminal clamp to the battery's positive terminal or to the corresponding starting aid terminal on the vehicle being started.
4. Connect a terminal clamp on the negative/- jump lead to the negative terminal of the battery or the corresponding engine or body earth connection on the other vehicle.
5. Connect the second terminal clamp to the negative terminal of the battery or to a corresponding engine or body earth connection on the vehicle being started.

Starting the engine

Never use spray products to start the engine.

1. Start the engine of the other vehicle and allow it to run for a few minutes at a slightly higher idle speed.
If starting a diesel vehicle: allow the engine of the other vehicle to run for approximately 10 minutes.
2. Start the engine of the vehicle to be started in the usual way.
If an initial attempt to start the engine fails, wait a few minutes before trying again to allow the discharged battery to recharge.
3. Allow both engines to run for a few minutes.
4. Disconnect the jump leads in reverse order to connection.

Check the battery and have it recharged if necessary.

Tow-starting and towing

Safety note

WARNING

Due to system limitations, individual functions may not work properly when tow-starting/towing with activated Intelligent Safety Systems. There is a risk of accident. Switch off all Intelligent Safety Systems before tow-starting/towing.

Manual transmission

Towing or pushing the vehicle

A broken-down vehicle can be towed or pushed.

To roll or push the vehicle, see page 120.

NOTE

If a parking brake cannot be manually unlocked, the vehicle cannot be moved or towed. There is a risk of material damage. Only have the vehicle transported on a truck bed.

Observe the following notes:

- ▶ Make sure that the ignition is switched on, otherwise low-beam headlights, rear lights, turn indicators and wipers will not be available.
- ▶ Do not tow the vehicle with the rear axle raised, otherwise the steering can turn.
- ▶ When the engine is not running, there is no power assistance. The steering and brakes will require extra effort to operate.
- ▶ Greater steering wheel movements are necessary.
- ▶ The towing vehicle must not be lighter than the towed vehicle, otherwise it may be unable to keep the towed vehicle reliably under control.

- Do not exceed a towing speed of 50 km/h, 30 mph.
- Do not exceed a towing distance of 50 km, 30 miles.

Towing truck

With driven front axle

⚠ NOTE

The vehicle may be damaged when raising and securing it.

There is a risk of material damage.

- Raise the vehicle with suitable equipment.
- Do not raise or secure the vehicle by its towing eye, body parts or chassis parts.

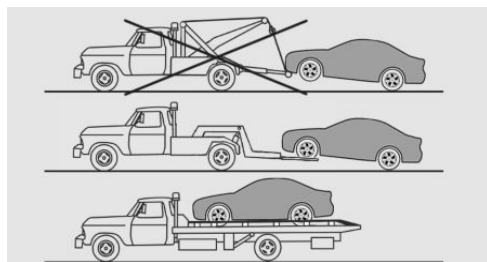

Have the vehicle transported by a towing truck with a hoisting frame, or hoisted onto a loading platform.

With xDrive

⚠ NOTE

If the vehicle is towed with one axle raised, the vehicle can be damaged. There is a risk of material damage. Only have the vehicle transported on a truck bed.

⚠ NOTE

The vehicle may be damaged when raising and securing it.

There is a risk of material damage.

- Raise the vehicle with suitable equipment.
- Do not raise or secure the vehicle by its towing eye, body parts or chassis parts.

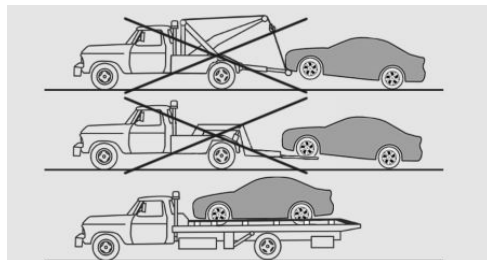

Only have the vehicle transported on a truck bed.

Steptronic transmission without xDrive: transporting the vehicle

General

The vehicle must not be towed if the front wheels are in contact with the ground.

Safety note

⚠ NOTE

If the vehicle is towed with a lifted rear axle, the vehicle can be damaged. There is a risk of material damage. Only have the vehicle towed with a lifted front axle or transported on a load platform.

Pushing the vehicle

To remove a broken-down vehicle from danger, it can be pushed for a short distance.

To roll or push the vehicle, see page 123.

Towing truck

NOTE

The vehicle may be damaged when raising and securing it.

There is a risk of material damage.

- ▷ Raise the vehicle with suitable equipment.
- ▷ Do not raise or secure the vehicle by its towing eye, body parts or chassis parts.

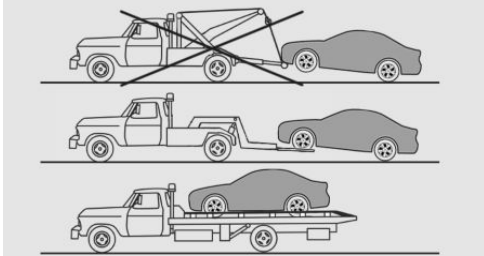

Have the vehicle transported by a towing truck with a hoisting frame, or hoisted onto a loading platform.

Steptronic transmission with xDrive: transporting the vehicle

General

Do not have the vehicle towed.

Pushing the vehicle

To remove a broken-down vehicle from danger, it can be pushed for a short distance.

To roll or push the vehicle, see page [123](#).

Towing truck

NOTE

The vehicle may be damaged when raising and securing it.

There is a risk of material damage.

- ▷ Raise the vehicle with suitable equipment.

- ▷ Do not raise or secure the vehicle by its towing eye, body parts or chassis parts.

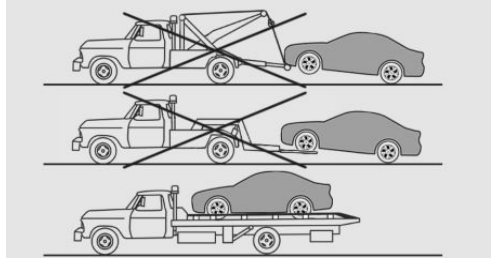

Only have the vehicle transported on a truck bed.

Towing other vehicles

General

Switch on the hazard warning lights in line with local regulations.

If the electrical system of the vehicle being towed has failed, the vehicle must be made identifiable to other road users, for instance by placing a sign or the warning triangle in the rear window.

Safety notes

WARNING

If the gross vehicle weight of the towing vehicle is less than that of the vehicle being towed, the towing eye may be torn off or it may not be possible to control the vehicle. There is a risk of accident. Make sure that the gross vehicle weight of the towing vehicle is greater than the weight of the vehicle being towed.

NOTE

If the tow bar or the towing rope is not attached correctly, other vehicle parts can be damaged. There is a risk of material damage. Attach the tow bar or towing rope to the towing eye correctly.

Tow bar

The towing eyes of both vehicles should be on the same side.

If it is impossible to avoid attaching the tow bar at an angle, note the following:

- ▶ Clearance may be limited when cornering.
- ▶ Lateral forces will be generated if the tow bar is installed at an angle.

Towing rope

Note the following if using a towing rope:

- ▶ Use nylon ropes or straps that will allow the vehicle to be towed smoothly.
- ▶ Fasten the towing rope so it is not twisted.
- ▶ Check the towing eye and towing rope fastening regularly.
- ▶ Do not exceed a towing speed of 50 km/h, 30 mph.
- ▶ Do not exceed a towing distance of 5 km, 3 miles.
- ▶ Ensure that the towing rope is taut when the towing vehicle drives off.

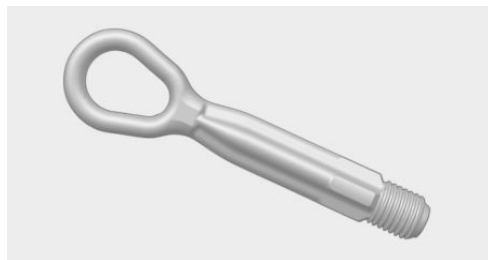
Towing eye**General**

Always keep the screw-on towing eye in the vehicle.

The towing eye can be screwed in at the front or rear of the vehicle.

The towing eye together with the on-board tool kit, see page 290, is located in the luggage compartment.

Using the towing eye:

- ▶ Only use the towing eye supplied with the vehicle and make sure that it is screwed in fully and is tight.
- ▶ Only use the towing eye for towing on paved roads.
- ▶ Avoid transverse loads on the towing eye, for example do not raise the vehicle by the towing eye.
- ▶ Check the towing eye fastening regularly.

Safety note**NOTE**

If the towing eye is not used as intended, the vehicle or towing eye may be damaged. There is a risk of material damage. Observe the notes on using the towing eye.

Thread for towing eye



Press the marking on the edge of the cover to push it out.

Tow-starting

Steptronic transmission

Do not attempt to tow-start or push-start the vehicle.

Due to the Steptronic transmission, it is not possible to start the engine by towing.

Have the cause of the starting problems rectified by a Service Partner of the manufacturer or another qualified Service Partner or a specialist workshop.

Manual transmission

If possible, do not tow-start the vehicle but start the engine using starting aid, see page 303. Only tow-start when the engine is cold if your vehicle has a catalytic converter.

1. Switching on the hazard warning lights, please observe country-specific regulations.
2. Switch on the ignition, see page 107.
3. Engage 3rd gear.
4. Tow-start with the clutch pressed and release the clutch slowly. Press the clutch again immediately after the engine starts.

5. Stop in a suitable location, remove the towbar or tow cable and switch off the hazard warning lights.
6. Have the vehicle checked by a Service Partner of the manufacturer or another qualified Service Partner or a specialist workshop.

General care

Vehicle equipment

This chapter describes all standard, country-specific and optional equipment available for the model series. It may therefore describe equipment and functions which are not installed in your vehicle, for example on account of the optional equipment selected or the national-market version. This also applies to safety-relevant functions and systems. Please comply with the relevant laws and regulations when using the corresponding functions and systems.

Washing the vehicle

General

Regularly remove foreign bodies, for example leaves, from the area below the windscreen with the bonnet raised.

Wash the vehicle frequently, especially in winter. Heavy soiling and road salt can cause damage to the vehicle.

Steam-jet cleaners and high-pressure cleaners

Safety note

NOTE

When cleaning with high-pressure cleaners, excessive pressure or excessive temperatures can damage various components. There is a risk of material damage. Maintain a sufficient distance and do not spray for an extended period of time. Comply with the instructions for the high-pressure cleaner.

Distances and temperature

- ▷ Maximum temperature: 60 °C/140 °F.
- ▷ Minimum distance to sensors, cameras, seals: 30 cm, 12 in.
- ▷ Minimum distance to the glass sunroof: 80 cm, 31.5 in.

Automatic car washes

Safety note

NOTE

The vehicle can be damaged if automatic washing bays or car washes are used incorrectly. There is a risk of material damage. Observe the following notes:

- ▷ Textile car washes or systems using soft brushes are preferable, to avoid damage to the paintwork.
- ▷ Do not drive into automatic car washes washing or washing bays with guide rails higher than 10 cm, 4 in, to avoid damage to the body.
- ▷ Note the maximum tyre width of the guide rail to avoid damage to tyres and rims.
- ▷ Fold in the exterior mirrors to avoid damaging them.
- ▷ Deactivate the wipers and the rain sensor (if fitted) to avoid damage to the wiper system.

Entering a car wash with a manual transmission

The vehicle must be able to roll freely while in the car wash.

To roll or push the vehicle, see page [120](#).

Entering a car wash with a Steptronic transmission

Safety note

NOTE

Selector lever position P is automatically engaged when the ignition is switched off. There is a risk of material damage. Do not switch the ignition off in car washes.

General

The vehicle must be able to roll freely while in the car wash.

To roll or push the vehicle, see page 123.

Some car washes require you to get out of the vehicle. It is not possible to lock the vehicle from the outside in selector lever position N. If an attempt is made to lock the vehicle, a signal sounds.

Exiting from a car wash

Make sure that the vehicle key is in the vehicle. Start the engine. Engine start, see page 108.

Headlights

Do not rub wet headlights dry and do not use abrasive or corrosive cleaning agents.

Soak impurities, for example insect residues, with shampoo and wash off with water.

Remove ice with a de-icer spray; do not use an ice scraper.

After washing the vehicle

After the vehicle has been washed, briefly apply the brakes to dry them, otherwise braking effectiveness may be temporarily reduced. The heat generated by braking dries the brake discs and brake pads and protects them against corrosion.

Completely remove residues on the windscreens to avoid affecting visibility due to smearing and to reduce wiping noise and wiper blade wear.

Vehicle care

Care products

General

BMW recommends using care and cleaning products from BMW. Suitable care products are available from a Service Partner of the manufacturer or another qualified Service Partner or a specialist workshop.

Safety note

WARNING

Cleaning agents can contain hazardous substances or constitute a health risk. There is a danger of injury. When cleaning the interior, open the doors or windows. Use only products that are intended for cleaning the vehicle's interior. Observe the notes on the packaging.

Vehicle paintwork

General

Regular care promotes driving safety and preserves your vehicle's value. Environmental effects in areas with high air pollution or natural contaminants, for example tree resin or pollen, may affect the vehicle paintwork. Take such factors into consideration when deciding on the frequency and scope of vehicle care measures.

Immediately remove aggressive substances, for example spilled fuel, oil, grease or bird droppings to prevent paintwork damage and discolouration.

Matt paintwork

Only use cleaning and care products that are suitable for vehicles with matt paintwork.

Leather care

Remove dust from the leather at regular intervals with a cloth or vacuum cleaner.

Dust and road dirt will otherwise become worked into pores and folds, resulting in considerable abrasion and causing the leather surface to become prematurely brittle.

In order to protect against discolouration, for example from clothing, clean and care for the leather approximately every two months.

Clean light-coloured leather more frequently as it has the tendency to soil faster.

Use leather cleaner, otherwise dirt and grease will attack the protective coating of the leather.

Care of upholstery fabrics

General

Regularly clean the upholstery with a vacuum cleaner.

In the event of heavy soiling, for example stains caused by drinks, use a soft sponge or a lint-free microfibre cloth with suitable interior cleaning agents.

Clean the upholstery up to the seams using wide wiping actions. Avoid rubbing vigorously.

Safety note

NOTE

Open Velcro fasteners on articles of clothing can damage the seat covers. There is a risk of material damage. Make sure that any Velcro fasteners on your clothing are closed.

Care of special parts

Light alloy wheels

When cleaning the wheels while they are installed on the vehicle, only use neutral rim cleaner with a pH value between 5 and 9. Do not use abrasive cleaners or steam cleaners above

60 °C/140 °F. Observe the manufacturer's instructions.

Corrosive, acidic or alkaline cleaners may destroy the protective coatings of adjacent parts, for example brake discs.

After cleaning, briefly apply the brakes to dry them. The heat generated by braking dries the brake discs and brake pads and protects them against corrosion.

Chrome surfaces

Carefully clean parts, for example the radiator grille and door handles, with plenty of water and add shampoo if need be, particularly if they have been exposed to road salt.

Rubber parts

The surfaces of rubber parts can be contaminated or lose their shine due to environmental influences. Only use water and suitable care products for cleaning.

Rubber parts subjected to high wear and tear should be treated regularly with rubber care products. Do not use silicone-based care products for treating rubber seals, otherwise these could be damaged and become a source of noise.

Fine wood parts

Clean fine wood trims and fine wood parts with a damp cloth only. Then dry them with a soft cloth.

Plastic parts

NOTE

Cleaning agents containing alcohol or solvents, for example nitro thinners, cold cleaners, fuel or similar can damage plastic parts. There is a risk of material damage. Clean with a microfibre cloth. Lightly moisten the cloth with water if necessary.

Clean with a microfibre cloth.

Lightly moisten the cloth with water if necessary.
Do not soak the headliner.

Seat belts

WARNING

Chemical cleaners can cause irreparable damage to the fabric of the seat belts. The protective function of the seat belts will be lost. There is a risk of injury or even death. Only use a mild soap and water solution for cleaning the seat belts.

Dirt on the belt straps can interfere with the action of the reel and is a safety hazard.

Clean only with a mild soap solution while still fitted to the vehicle.

Do not allow seat belts to retract until they are dry.

Carpets and foot mats

WARNING

Objects in the driver's footwell can restrict the pedal travel or block a pedal that has been pressed. There is a risk of accident. Ensure that items in the vehicle are stowed securely and cannot get into the driver's footwell. Only use floor mats that are suitable for the vehicle and can be securely fastened to the floor. Do not use loose floor mats, and do not place several floor mats on top of one another. Make sure that there is sufficient space for the pedals. Ensure that floor mats are securely reattached after removal, for example for cleaning.

Floor mats can be removed from the vehicle to enable the interior to be cleaned more thoroughly.

In the event of heavy soiling, clean floor carpets using a microfibre cloth and water or textile cleaner. Rub back and forth in the direction of travel to prevent matting.

Trailer tow hitch with removable ball linkage/mount for rear luggage rack

Keep ball linkage and bracket clean.

Grease or oil bearing locations, sliding surfaces and the small balls on the bracket pin regularly with resin-free grease or oil.

Before using steam cleaners or high-pressure cleaners on the vehicle, remove the ball linkage and insert the cover into the bracket.

Do not clean ball linkage with a steam cleaner or high pressure cleaner.

Sensors/camera lenses

Clean sensors or camera lenses using a cloth moistened with a small amount of glass cleaner.

Displays/screens/projection screen

NOTE

Chemical cleaners, moisture or fluids of all kinds can damage the surface of displays and screens. There is a risk of material damage. Clean with a clean, anti-static microfibre cloth.

NOTE

Incorrect cleaning can damage the surfaces of displays. There is a risk of material damage. Avoid applying excessive pressure and do not use abrasive materials.

Clean with a clean, anti-static microfibre cloth. Stubborn dirt on the projection screen of the Head-Up Display should be removed with a microfibre cloth which has been moistened lightly with methylated spirit. Projection screen, see page 142.

Laying up the vehicle

Special measures need to be taken if putting the vehicle out of use for longer than three months. Additional information is available from a Service

Partner of the manufacturer or another qualified
Service Partner or a specialist workshop.

Technical data

Vehicle equipment

This chapter describes all standard, country-specific and optional equipment available for the model series. It may therefore describe equipment and functions which are not installed in

your vehicle, for example on account of the optional equipment selected or the national-market version. This also applies to safety-relevant functions and systems. Please comply with the relevant laws and regulations when using the corresponding functions and systems.

General

The technical data and specifications in the Owner's Handbook are reference figures. Data relating to a specific vehicle can deviate from this, for example, due to selected optional equipment, national-market versions or country-specific measurement methods. Detailed values can be found in the permit documents, on informa-

tion plates on the vehicle or can be requested from a Service Partner of the manufacturer or another qualified Service Partner or a specialist workshop.

The information in the vehicle documents always takes precedence over the information in the Owner's Handbook.

Dimensions

Dimensions can vary depending on the model version, equipment or country-specific measurement method.

The heights specified do not take into account add-on parts, for example a roof aerial, roof rails

or spoiler. The heights can deviate, for example, due to selected optional equipment, tyres, loads and suspension design.

BMW 2 Series Active Tourer

Width with mirrors	mm (in)	2038 (80.2)
Width without mirrors	mm (in)	1800 (70.9)
Height	mm (in)	1555 (61.2)
Length	mm (in)	4354 (171.4)
Wheelbase	mm (in)	2670 (105.1)
Smallest turning circle dia.	m (ft)	11.3 (37.1)

Weights

216i

Kerb weight ready for use, with 75 kg, 165 lb, load, tank
90 % full, no optional equipment

Manual transmission	kg (lb)	1440 (3175)
---------------------	---------	-------------

Steptronic transmission	kg (lb)	1460 (3219)
-------------------------	---------	-------------

Permitted total weight

Manual transmission	kg (lb)	1910 (4211)
---------------------	---------	-------------

Steptronic transmission	kg (lb)	1940 (4277)
-------------------------	---------	-------------

Payload

Manual transmission	kg (lb)	545 (1202)
---------------------	---------	------------

Steptronic transmission	kg (lb)	555 (1224)
-------------------------	---------	------------

Front axle load limit

Manual transmission	kg (lb)	985 (2172)
---------------------	---------	------------

Steptronic transmission	kg (lb)	1015 (2238)
-------------------------	---------	-------------

Rear axle load limit	kg (lb)	970 (2138)
----------------------	---------	------------

Roof load	kg (lb)	75 (165)
-----------	---------	----------

218i

Kerb weight ready for use, with 75 kg, 165 lb, load, tank
90 % full, no optional equipment

Manual transmission	kg (lb)	1445 (3186)
---------------------	---------	-------------

Steptronic transmission	kg (lb)	1475 (3252)
-------------------------	---------	-------------

Permitted total weight

Manual transmission	kg (lb)	1920 (4233)
---------------------	---------	-------------

Steptronic transmission	kg (lb)	1945 (4288)
-------------------------	---------	-------------

Payload

Manual transmission	kg (lb)	550 (1213)
---------------------	---------	------------

Steptronic transmission	kg (lb)	545 (1202)
-------------------------	---------	------------

218i

Front axle load limit

Manual transmission kg (lb) 990 (2183)

Steptronic transmission kg (lb) 1020 (2249)

Rear axle load limit

Manual transmission kg (lb) 970 (2138)

Steptronic transmission kg (lb) 970 (2138)

Roof load kg (lb) 75 (165)

220iKerb weight ready for use, with 75 kg, 165 lb, load, tank
90 % full, no optional equipment kg (lb) 1490 (3285)

Permitted total weight kg (lb) 1970 (4343)

Payload kg (lb) 555 (1224)

Front axle load limit kg (lb) 1045 (2304)

Rear axle load limit kg (lb) 970 (2138)

Roof load kg (lb) 75 (165)

225i xDriveKerb weight ready for use, with 75 kg, 165 lb, load, tank
90 % full, no optional equipment kg (lb) 1595 (3516)

Permitted total weight kg (lb) 2090 (4608)

Payload kg (lb) 570 (1257)

Front axle load limit kg (lb) 1090 (2403)

Rear axle load limit kg (lb) 1035 (2282)

Roof load kg (lb) 75 (165)

216dKerb weight ready for use, with 75 kg, 165 lb, load, tank
90 % full, no optional equipment

Manual transmission kg (lb) 1500 (3307)

216d

Steptronic transmission	kg (lb)	1505 (3318)
Permitted total weight		
Manual transmission	kg (lb)	1970 (4343)
Steptronic transmission	kg (lb)	1975 (4354)
Payload		
Manual transmission	kg (lb)	545 (1202)
Steptronic transmission	kg (lb)	545 (1202)
Front axle load limit		
Manual transmission	kg (lb)	1030 (2271)
Steptronic transmission	kg (lb)	1050 (2315)
Rear axle load limit		
Manual transmission	kg (lb)	1005 (2216)
Steptronic transmission	kg (lb)	1000 (2205)
Roof load	kg (lb)	75 (165)

218d

Kerb weight ready for use, with 75 kg, 165 lb, load, tank
90 % full, no optional equipment

Manual transmission	kg (lb)	1530 (3373)
Steptronic transmission	kg (lb)	1565 (3450)
Permitted total weight		
Manual transmission	kg (lb)	2010 (4431)
Steptronic transmission	kg (lb)	2040 (4497)
Payload		
Manual transmission	kg (lb)	555 (1224)
Steptronic transmission	kg (lb)	550 (1213)
Front axle load limit		
Manual transmission	kg (lb)	1055 (2326)
Steptronic transmission	kg (lb)	1090 (2403)

218d

Rear axle load limit	kg (lb)	1000 (2205)
Roof load	kg (lb)	75 (165)

220d

Kerb weight ready for use, with 75 kg, 165 lb, load, tank 90 % full, no optional equipment	kg (lb)	1560 (3439)
Permitted total weight	kg (lb)	2045 (4508)
Payload	kg (lb)	560 (1235)
Front axle load limit	kg (lb)	1090 (2403)
Rear axle load limit	kg (lb)	1000 (2205)
Roof load	kg (lb)	75 (165)

218d xDrive

Kerb weight ready for use, with 75 kg, 165 lb, load, tank 90 % full, no optional equipment	kg (lb)	1620 (3571)
Permitted total weight	kg (lb)	2100 (4630)
Payload	kg (lb)	555 (1224)
Front axle load limit	kg (lb)	1110 (2447)
Rear axle load limit	kg (lb)	1035 (2282)
Roof load	kg (lb)	75 (165)

220d xDrive

Kerb weight ready for use, with 75 kg, 165 lb, load, tank 90 % full, no optional equipment	kg (lb)	1620 (3571)
Permitted total weight	kg (lb)	2105 (4641)
Payload	kg (lb)	560 (1235)
Front axle load limit	kg (lb)	1110 (2447)
Rear axle load limit	kg (lb)	1035 (2282)
Roof load	kg (lb)	75 (165)

Trailer operation

216i

Trailer loads according to EU operating permit. Consult a Service Partner of the manufacturer or another qualified Service Partner or a specialist workshop about options for increasing the loads.

Trailer load without brake

Manual transmission	kg (lb)	715 (1576)
---------------------	---------	------------

Steptronic transmission	kg (lb)	730 (1609)
-------------------------	---------	------------

Trailer load with brake on upward gradient up to 12 %	kg (lb)	1100 (2425)
---	---------	-------------

Trailer load with brake on upward gradient up to 8 %	kg (lb)	1100 (2425)
--	---------	-------------

Maximum trailer nose weight	kg (lb)	75 (165)
-----------------------------	---------	----------

Minimum trailer nose weight	kg (lb)	25 (55)
-----------------------------	---------	---------

Rear axle load limit, towing vehicle

Manual transmission	kg (lb)	1090 (2403)
---------------------	---------	-------------

Steptronic transmission	kg (lb)	1080 (2381)
-------------------------	---------	-------------

Permitted total weight, towing vehicle

Manual transmission	kg (lb)	1985 (4376)
---------------------	---------	-------------

Steptronic transmission	kg (lb)	2015 (4442)
-------------------------	---------	-------------

218i

Trailer loads according to EU operating permit. Consult a Service Partner of the manufacturer or another qualified Service Partner or a specialist workshop about options for increasing the loads.

Trailer load without brake

Manual transmission	kg (lb)	715 (1576)
---------------------	---------	------------

Steptronic transmission	kg (lb)	730 (1609)
-------------------------	---------	------------

Trailer load with brake on upward gradient up to 12 %	kg (lb)	1300 (2866)
---	---------	-------------

Trailer load with brake on upward gradient up to 8 %	kg (lb)	1300 (2866)
--	---------	-------------

Maximum trailer nose weight	kg (lb)	75 (165)
-----------------------------	---------	----------

Minimum trailer nose weight	kg (lb)	25 (55)
-----------------------------	---------	---------

Rear axle load limit, towing vehicle

218i

Manual transmission	kg (lb)	1090 (2403)
Steptronic transmission	kg (lb)	1085 (2392)
Permitted total weight, towing vehicle		
Manual transmission	kg (lb)	1995 (4398)
Steptronic transmission	kg (lb)	2020 (4453)

220i

Trailer loads according to EU operating permit. Consult a Service Partner of the manufacturer or another qualified Service Partner or a specialist workshop about options for increasing the loads.

Trailer load without brake	kg (lb)	740 (1631)
Trailer load with brake on upward gradient up to 12 %	kg (lb)	1500 (3307)
Trailer load with brake on upward gradient up to 8 %	kg (lb)	1500 (3307)
Maximum trailer nose weight	kg (lb)	75 (165)
Minimum trailer nose weight	kg (lb)	25 (55)
Rear axle load limit, towing vehicle	kg (lb)	1085 (2392)
Permitted total weight, towing vehicle	kg (lb)	2045 (4508)

225i xDrive

Trailer loads according to EU operating permit. Consult a Service Partner of the manufacturer or another qualified Service Partner or a specialist workshop about options for increasing the loads.

Trailer load without brake	kg (lb)	750 (1653)
Trailer load with brake on upward gradient up to 12 %	kg (lb)	1600 (3527)
Trailer load with brake on upward gradient up to 8 %	kg (lb)	1600 (3527)
Maximum trailer nose weight	kg (lb)	75 (165)
Minimum trailer nose weight	kg (lb)	25 (55)
Rear axle load limit, towing vehicle	kg (lb)	1145 (2524)
Permitted total weight, towing vehicle	kg (lb)	2165 (4773)

216d

Trailer loads according to EU operating permit. Consult a Service Partner of the manufacturer or another qualified Service Partner or a specialist workshop about options for increasing the loads.

Trailer load without brake		
Manual transmission	kg (lb)	750 (1653)
Steptronic transmission	kg (lb)	750 (1653)
Trailer load with brake on upward gradient up to 12 %		
	kg (lb)	1300 (2866)
Trailer load with brake on upward gradient up to 8 %		
	kg (lb)	1300 (2866)
Maximum trailer nose weight		
	kg (lb)	75 (165)
Minimum trailer nose weight		
	kg (lb)	25 (55)
Rear axle load limit, towing vehicle		
Manual transmission	kg (lb)	1115 (2458)
Steptronic transmission	kg (lb)	1110 (2447)
Permitted total weight, towing vehicle		
Manual transmission	kg (lb)	2045 (4508)
Steptronic transmission	kg (lb)	2050 (4519)

218d

Trailer loads according to EU operating permit. Consult a Service Partner of the manufacturer or another qualified Service Partner or a specialist workshop about options for increasing the loads.

Trailer load without brake		
	kg (lb)	750 (1653)
Trailer load with brake on upward gradient up to 12 %		
	kg (lb)	1300 (2866)
Trailer load with brake on upward gradient up to 8 %		
	kg (lb)	1300 (2866)
Maximum trailer nose weight		
	kg (lb)	75 (165)
Minimum trailer nose weight		
	kg (lb)	25 (55)
Rear axle load limit, towing vehicle		
	kg (lb)	1120 (2469)
Permitted total weight, towing vehicle		
Manual transmission	kg (lb)	2085 (4597)
Steptronic transmission	kg (lb)	2115 (4663)

220d

Trailer loads according to EU operating permit. Consult a Service Partner of the manufacturer or another qualified Service Partner or a specialist workshop about options for increasing the loads.

Trailer load without brake	kg (lb)	750 (1653)
Trailer load with brake on upward gradient up to 12 %	kg (lb)	1500 (3307)
Trailer load with brake on upward gradient up to 8 %	kg (lb)	1500 (3307)
Maximum trailer nose weight	kg (lb)	75 (165)
Minimum trailer nose weight	kg (lb)	25 (55)
Rear axle load limit, towing vehicle	kg (lb)	1120 (2469)
Permitted total weight, towing vehicle	kg (lb)	2120 (4674)

218d xDrive

Trailer loads according to EU operating permit. Consult a Service Partner of the manufacturer or another qualified Service Partner or a specialist workshop about options for increasing the loads.

Trailer load without brake	kg (lb)	750 (1653)
Trailer load with brake on upward gradient up to 12 %	kg (lb)	1600 (3527)
Trailer load with brake on upward gradient up to 8 %	kg (lb)	1600 (3527)
Maximum trailer nose weight	kg (lb)	75 (165)
Minimum trailer nose weight	kg (lb)	25 (55)
Rear axle load limit, towing vehicle	kg (lb)	1165 (2568)
Permitted total weight, towing vehicle	kg (lb)	2175 (4795)

220d xDrive

Trailer loads according to EU operating permit. Consult a Service Partner of the manufacturer or another qualified Service Partner or a specialist workshop about options for increasing the loads.

Trailer load without brake	kg (lb)	750 (1653)
Trailer load with brake on upward gradient up to 12 %	kg (lb)	1600 (3527)
Trailer load with brake on upward gradient up to 8 %	kg (lb)	1600 (3527)
Maximum trailer nose weight	kg (lb)	75 (165)
Minimum trailer nose weight	kg (lb)	25 (55)

220d xDrive

Rear axle load limit, towing vehicle	kg (lb)	1160 (2557)
Permitted total weight, towing vehicle	kg (lb)	2180 (4806)

Filling capacities**BMW 2 Series Active Tourer**

Fuel tank, approximately.	Litres (gal)	51.0 (11.2)
Larger-capacity fuel tank, approximately	Litres (gal)	61.0 (13.4)

Observe the additional information on fuel quality, see page [256](#).

Seats for child restraint systems

Vehicle equipment

This chapter describes all standard, country-specific and optional equipment available for the model series. It may therefore describe equipment and functions which are not installed in your vehicle, for example on account of the optional equipment selected or the national-market version. This also applies to safety-relevant functions and systems. Please comply with the relevant laws and regulations when using the corresponding functions and systems.

Information for manufacturers of child seats

General

Information about which child restraint systems can be used on the seats in question in accordance with the ECE-R 16 and ECE-R 129 standard.

Left-hand drive vehicles: Suitability of child restraint systems for each vehicle seat

Seat position	1		3 - Airbag ON		3 -a)		4		5		6	
	Airbag OFF											
Seat position suitable for universal fastening with a belt.	No	No			Yes			Yes	No	Yes		
i-Size seat position.	No	No			No			No	No	No		
Seat position suitable for side mounting: L1/L2.	No	No			No			Yes	No	Yes		
Largest rear-facing mounting: R1/R2X/R2/R3.	No	No			R3			R3	No	R3		
Largest front-facing mounting: F2X/F2/F3.	No	No			F3			F3	No	F3		
Largest suitable booster mount: B2/B3.	No	No			No			No	No	No		

A seat position without i-Size approval is not compatible with an i-Size support stand.

A seat position with lower ISOFIX anchors, but with no Top Tether, is not available.

There are no seat belt buckles for adults between the two bottom ISOFIX anchors.

a) Only use ISOFIX child restraint system if equipped with ISOFIX child safety seat fasteners.

Seat number	Position in the vehicle	Seat number	Position in the vehicle
1	Front left	4	2nd seat row left
2	Front centre	5	2nd seat row centre
3	Front right	6	2nd seat row right

Seat number	Position in the vehicle
7	3rd seat row left
8	3rd seat row centre
9	3rd seat row right

Right-hand drive vehicles: suitability of child restraint systems for each vehicle seat

Seat position	1 -	1 -a)	3	4	5	6
	Airbag ON	Airbag OFF				
Seat position suitable for universal fastening with a belt.	No	Yes	No	Yes	No	Yes
i-Size seat position.	No	No	No	Yes	No	Yes
Seat position suitable for side mounting: L1/L2.	No	No	No	Yes	No	Yes
Largest rear-facing mounting: R1/R2X/R2/R3.	No	R3	No	R3	No	R3
Largest front-facing mounting: F2X/F2/F3.	No	F3	No	F3	No	F3
Largest suitable booster mount: B2/B3.	No	No	No	No	No	No

A seat position without i-Size approval is not compatible with an i-Size support stand.

A seat position with lower ISOFIX anchors, but with no Top Tether, is not available.

There are no seat belt buckles for adults between the two bottom ISOFIX anchors.

a) Only use ISOFIX child restraint system if equipped with ISOFIX child safety seat fasteners.

Seat number	Position in the vehicle
1	Front left
2	Front centre
3	Front right
4	2nd seat row left
5	2nd seat row centre
6	2nd seat row right
7	3rd seat row left
8	3rd seat row centre
9	3rd seat row right

Appendix

Here is where any updates to the Owner's Handbook for the vehicle are listed.

Updates after going to press

After the copy deadline for the integrated Owner's Handbook in the vehicle, the following chapters were updated in the printed Owner's Handbook:

- ▷ Operation: opening and closing: vehicle key: Safety Information.
- ▷ Operation: opening and closing: vehicle key: change battery:
- ▷ Operation: seats, mirrors and steering wheel: seats and head restraints: seat belts: general.
- ▷ Mobility: wheels and tyres: tyre inflation pressure: tyre inflation pressure inscriptions: on the door pillar.
- ▷ Mobility: help in the event of a breakdown: fire extinguisher: overview.

Everything from A to Z

Index

A

- ABS Anti-lock Brake System [175](#)
- ACC, Active Cruise Control [180](#)
- Acceleration assistant, see Launch Control [126](#)
- Accessories and parts [9](#)
- Acknowledgement signals [77](#)
- Activation, airbags [154](#)
- Active bonnet, see Active pedestrian protection [155](#)
- Active carbon filter [207](#)
- Active Cruise Control, ACC [180](#)
- Active pedestrian protection [155](#)
- Adaptive brake light, see Dynamic brake lights [173](#)
- Adaptive Headlights [147](#)
- Adaptive suspension [179](#)
- AdBlue, at low temperatures [257](#)
- AdBlue at minimum [258](#)
- AdBlue, replenishing [258](#)
- AdBlue, replenishing yourself [258](#)
- AdBlue, see BMW diesel with BluePerformance [257](#)
- Additives, engine oil grades [283](#)
- Age of tyres [264](#)
- Airbags [152](#)
- Airbags, indicator/warning lamp [153](#)
- Airbag switch, see Key switch for front passenger airbags [154](#)
- Air conditioning [201, 204](#)
- Air conditioning function, air conditioning [205](#)
- Air conditioning system [201](#)
- Air distribution, manual [203, 206](#)
- Air flow, air conditioning [203](#)
- Air pressure, tyres [262](#)
- Alarm system [78](#)
- All-season tyres, see Winter tyres [265](#)
- Amazon Alexa Car Integration [46](#)
- Ambient lighting [151](#)
- Amount of air, automatic air conditioning [206](#)
- Antifreeze protection, see Washer fluid [118](#)
- Antifreeze, see Washer fluid [118](#)
- Anti-lock Brake System [175](#)
- Anti-theft alarm system, see Alarm system [78](#)
- Anti-theft security system, locking wheel bolts [274](#)
- Anti-theft security system, vehicle [63](#)
- Anti-trap mechanism, glass sunroof [82](#)
- Anti-trap mechanism, windows [80](#)
- Apps, see Owner's Handbook for Navigation, Entertainment, Communication [6](#)
- Aquaplaning [228](#)
- Around the centre console [34](#)
- Around the headliner [35](#)
- Arrival time [140](#)
- Ashtray [210](#)
- Attentiveness Assistant [173](#)
- Audio, see Owner's Handbook for Navigation, Entertainment, Communication [6](#)
- Automatic air conditioning [204](#)
- Automatic air recirculation control [206](#)
- Automatic car wash [309](#)
- Automatic Cruise Control with Stop&Go function [180](#)
- Automatic dimming, see High beam assistant [148](#)
- Automatic driving lights control [146](#)
- Automatic gearbox, see Steptronic transmission [120](#)
- Automatic locking [77](#)
- Automatic parking function, exterior mirror [95](#)
- Automatic Start/Stop function [110](#)
- Automatic start-stop function [110](#)
- Automatic tailgate [72](#)
- Automatic unlocking [77](#)
- AUTO program, automatic air conditioning [205](#)
- AUTO program, intensity [206](#)
- Auxiliary ventilation [208](#)
- Average consumption [139](#)
- Average speed [139](#)

Avoiding false warnings [79](#)
Axle loads, permitted [315](#)

B

Backrest contour, see Lumbar support [86](#)
Backrest, seats [84](#)
Backrest width [87](#)
Back seats [87](#)
Ball linkage [241](#)
Battery changing, vehicle key [65](#)
Battery, disposing of [298](#)
Battery, vehicle [296](#)
Belts, see Seat belts [88](#)
Biodiesel [257](#)
Black ice, see Outside temperature warning [133](#)
Blower, see Air flow [203](#)
Blower, see Amount of air [206](#)
Bluetooth connection [53](#)
Blu-ray, see Owner's Handbook for Navigation, Entertainment, Communication [6](#)
BMW diesel with BluePerformance [257](#)
BMW home page, see Internet [6](#)
BMW Internet site [6](#)
BMW Maintenance System [287](#)
BMW Roadside Assistance [300](#)
BMW Services, see Owner's Handbook for Navigation, Entertainment, Communication [6](#)
Bonnet [279](#)
Bonus range, ECO PRO [248](#)
Bottle holder, see Cup holder [223](#)
Bracket for rear luggage rack [233](#), [241](#)
Brake assist [175](#)
Brake lights, adaptive, see Dynamic brake lights [173](#)
Brake lights, dynamic [173](#)
Braking, notes [228](#)
Braking safely [228](#)
Breakdown, help [300](#)
Brightness, control display [49](#)
Bulbs and lights [291](#)
Button, central locking system [67](#)
Buttons on the steering wheel [32](#)
Button, start/stop [107](#)

C

Camera-based assistance systems, see Intelligent Safety [163](#)
Camera-based Cruise Control, ACC [180](#)
Camera lenses, care [312](#)
Camera, Reversing Assist camera [192](#)
Can holder, see Cup holder [223](#)
Care [309](#)
Care, Head-Up Display [312](#)
Care, light-alloy wheels [311](#)
Care products [310](#)
Care, vehicle [310](#)
Cargo position, rear seat backrest [217](#)
Caring for displays, monitors [312](#)
Car jack [274](#)
Carpet, care [312](#)
Carrying children safely [97](#)
Car wash [309](#)
Car wash, automatic [309](#)
Catalytic converter, see Hot exhaust system [227](#)
CBS Condition Based Service [287](#)
Central locking switch, see Central locking system [67](#)
Central locking system [67](#)
Central screen, see Control display [38](#)
Centre armrest [223](#)
Centre console [34](#)
Changes, technical, see Your own safety [8](#)
Changing bulbs, see Replacing bulbs [291](#)
Changing gear, Steptronic transmission [120](#)
Changing, wheels and tyres [265](#)
Charging a smartphone, see Wireless charging dock [213](#)
Charging dock for smartphones, see Wireless charging dock [213](#)
Chassis number, see Vehicle identification number [15](#)
Check Control [128](#)
Checking the engine oil level [281](#)
Checking the engine oil level electronically [281](#)
Checking the oil level electronically [281](#)
Child's seats [97](#)
Child locks [106](#)
Children, carrying [97](#)
Child restraints [97](#)

- Child safety seat fasteners, ISOFIX [100](#)
- Child seat classes, see Suitable seats for child restraint systems [102](#)
- Child seat mounting [98](#)
- Chrome parts, care [311](#)
- Cigarette lighter [210](#)
- Cleaning displays, monitors [312](#)
- Cleaning, Head-Up Display [312](#)
- Coasting [250](#)
- Coasting in idle [250](#)
- Coat hooks [224](#)
- Cold start, see Engine start [109](#)
- Collision warning with light city braking function [164](#)
- Comfort Access [68](#)
- Comfort closing, vehicle key [64](#)
- Comfort opening, vehicle key [63](#)
- COMFORT program, driving dynamics [178](#)
- Communication, see Owner's Handbook for Navigation, Entertainment, Communication [6](#)
- Compact wheel, see Emergency wheel [276](#)
- Compartments in the doors [223](#)
- Compatible devices, see Suitable devices [52](#)
- Computer, see On-board computer [138](#)
- Concierge Service, see Owner's Handbook for Navigation, Entertainment, Communication [6](#)
- Condensation on windows [203](#), [207](#)
- Condensation under the vehicle [229](#)
- Condition Based Service CBS [287](#)
- ConnectedDrive, see Owner's Handbook for Navigation, Entertainment, Communication [6](#)
- Connecting a device [52](#)
- Connecting electrical devices, see Sockets [211](#)
- Consumption history [248](#)
- Consumption, see Average consumption [139](#)
- Consumption, see Current consumption [134](#)
- Contactless closing of tailgate [69](#)
- Contactless opening of tailgate [69](#)
- Contacts, see Owner's Handbook for Navigation, Entertainment, Communication [6](#)
- Continuing a journey with a flat tyre [159](#), [162](#)
- Control display [38](#)
- Control display, brightness [49](#)
- Controller [38](#), [39](#)
- Control systems, driving stability [175](#)
- Converting the headlights, see Right-hand/left-hand traffic [150](#)
- Coolant [285](#)
- Cooling, maximum [205](#)
- Cooling system [285](#)
- Cornering light [148](#)
- Corrosion of brake discs [229](#)
- Cruise Control, active [180](#)
- Cruise Control, see Cruise Control [186](#)
- Cruise Control with distance control, see Camera-based Cruise Control, ACC [180](#)
- Cruise Control without distance control, see Cruise Control [186](#)
- Cup holder [223](#)
- Current consumption [134](#)
- Customer support, see Owner's Handbook for Navigation, Entertainment, Communication [6](#)
- ## D
- Damage, tyres [264](#)
- Data protection, settings [51](#)
- Data, see Deleting personal data [51](#)
- Data storage medium, see Vehicle data and data protection [9](#)
- Data, technical [314](#)
- Date [49](#)
- Date, display [133](#)
- Daytime running lights [147](#)
- DCC, see Cruise Control [186](#)
- Deactivation, airbags [154](#)
- Defrosting, see Defrosting windows [203](#), [207](#)
- Defrosting windows [203](#), [207](#)
- Defrost, see Defrosting windows [203](#), [207](#)
- Deleting personal data [51](#)
- Departure schedule, see Auxiliary ventilation [208](#)
- Destination entry, see Owner's Handbook for Navigation, Entertainment, Communication [6](#)
- Device list [52](#)
- Diesel fuel [257](#)
- Diesel particulate filter, see Exhaust gas particle filter [227](#)
- Digital clock [133](#)
- Dimensions [314](#)
- Dimming exterior mirror [95](#)

Dimming interior mirror [95](#)
Dipped headlight, replacing the lamps [292](#)
Dipping headlights, see High beam assistant [148](#)
Direct selection buttons, see Functional bookmarks [42](#)
Display date [133](#)
Display, engine temperature [140](#)
Display, iDrive [36](#)
Display lighting, see Instrument lighting [150](#)
Disposal, coolant [286](#)
Disposal, vehicle battery [298](#)
Disposing of the old battery [298](#)
Distance to destination [140](#)
Distance warning, see PDC [189](#)
Downhill gradients [229](#)
Drive mode, ECO PRO [246](#)
Drive mode, see Driving Experience Control [177](#)
Drive-off assistant [179](#)
Driver assistance, see Intelligent Safety [163](#)
Driver profiles [74](#)
Driver profiles, exporting profile [75](#)
Driver profiles, import profile [76](#)
Driving Excitement, SPORT [141](#)
Driving Experience Control [177](#)
Driving hints [227](#)
Driving information, ECO PRO [248](#)
Driving information, general [227](#)
Driving information, running in [226](#)
Driving lights control, automatic [146](#)
Driving on racetracks [230](#)
Driving path lines, Reversing Assist camera [194](#)
Driving Stability Control Systems [175](#)
Driving, Start/Stop button [107](#)
Driving style analysis, ECO PRO [251](#)
Driving through water [228](#)
Drying air, see Air conditioning function [205](#)
DSC Dynamic Stability Control [175](#)
DTC, Dynamic Traction Control [176](#)
DVD, video, see Owner's Handbook for Navigation, Entertainment, Communication [6](#)
Dynamic brake lights [173](#)
Dynamic damping, see Adaptive suspension [179](#)
Dynamic Stability Control DSC [175](#)
Dynamic Traction Control DTC [176](#)

E

Easy Opener [69](#)
ECO PRO [246](#)
ECO PRO, bonus range [248](#)
ECO PRO, driving style analysis [251](#)
ECO PRO, program, driving dynamics [178](#)
ECO PRO, route-ahead assistant [249](#)
ECO PRO, tip [248](#)
Efficiency display, ECO PRO [248](#)
EfficientDynamics, displays [248](#)
Electrical power window switches [79](#)
Electric steering wheel lock [96](#)
Electronic oil measurement [281](#)
Electronic Stability Program, ESP, see DSC [175](#)
E-mail, see Owner's Handbook for Navigation, Entertainment, Communication [6](#)
Emergency assistance, see BMW Roadside Assistance [300](#)
Emergency braking, see PostCrash – iBrake [174](#)
Emergency call [301](#)
Emergency release, fuel tank filler flap [255](#)
Emergency release, transmission lockout [126](#)
Emergency running properties, tyres [266](#)
Emergency wheel [276](#)
Energy control [134](#)
Energy recuperation [134](#)
Engine, automatic start-stop function [110](#)
Engine compartment [278](#)
Engine coolant [285](#)
Engine idling when driving, see Coasting [250](#)
Engine oil [281](#)
Engine oil change [284](#)
Engine oil filler neck [282](#)
Engine oil grades for topping up [283](#)
Engine oil, topping up [282](#)
Engine start [108](#)
Engine start, see Starting aid [303](#)
Engine temperature, display [140](#)
Entering an address, Navigation, see Owner's Handbook for Navigation, Entertainment, Communication [6](#)
Entering letters and numbers [36](#)
Entertainment, see Owner's Handbook for Navigation, Entertainment, Communication [6](#)
ESP, Electronic Stability Program, see DSC [175](#)

Exchanging, wheels and tyres [265](#)
Exhaust gas particle filter [227](#)
Exhaust, see Exhaust system [227](#)
Exhaust system [227](#)
Exterior mirror [94](#)
Exterior mirror, automatically dimming [95](#)
Exterior mirror, automatic parking function [95](#)
Exterior mirrors, malfunction [94](#)
External start, see Starting aid [303](#)
Eye for securing cable, towing a trailer [244](#)

F

Failure message, see Check Control [128](#)
False warnings, see Avoiding false warnings [79](#)
Fan run-on, see Exhaust gas particle filter [227](#)
Fastening seat belts, see Seat belts [88](#)
Fatigue warning function [173](#)
Fault displays, see Check Control [128](#)
Favourites buttons, see Functional book-marks [42](#)
Filler neck for engine oil [282](#)
Filter, see Microfilter [203](#)
Filter, see Microfilter/active carbon filter [207](#)
Fine wood, care [311](#)
Fire extinguisher [302](#)
First-aid kit [300](#)
Flat tyre, continuing a journey [159](#), [162](#)
Flat tyre, flat tyre monitor RPA [160](#)
Flat tyre message, RPA [161](#)
Flat tyre message, TPM [158](#)
Flat tyre monitor RPA [160](#)
Flat tyre, remedying [267](#)
Flat tyre warning lamp, RPA [161](#)
Flat tyre warning lamp, TPM [158](#)
Flat tyre, wheel change [272](#)
Flood, driving through [228](#)
Floor carpet, care [312](#)
Fold-down table, rear [215](#)
Folding table, see Fold-down table, rear [215](#)
Fold-out position, windscreen wiper [117](#)
Foot brake [228](#)
Foot mats, care [312](#)
Fording depth, water [228](#)
For more information on connections [52](#)
Four-wheel drive, see xDrive [177](#)

Front airbags [152](#)
Front fog lights [149](#)
Front head rests [91](#)
Front lights [292](#)
Front neck supports, see Front head rests [91](#)
Front passenger's side exterior mirror, tilting down, see Automatic parking function [95](#)
Front passenger airbags, deactivating/activating [154](#)
Front passenger airbags, indicator lamp [155](#)
Front seat passenger backrest, folding down [218](#)
Front seats [84](#)
Fuel [256](#)
Fuel filler cap [254](#)
Fuel gauge [132](#)
Fuel quality [256](#)
Fuel recommendation [256](#)
Fuel tank capacity [323](#)
Fuel tank filler flap [254](#)
Fuel tank filler flap, emergency release [255](#)
Fuel tank, see Capacities [323](#)
Functional bookmarks, iDrive [42](#)
Fuses [299](#)

G

Gearbox, see Manual gearbox [119](#)
Gearbox, see Steptronic transmission [120](#)
Gearshift, see Manual gearbox [119](#)
General driving information [227](#)
General settings [48](#)
Glare protection [210](#)
Glass sunroof, initialising system [82](#)
Glass sunroof, see Panoramic glass sunroof [81](#)
Glove compartment [222](#)
GPS, navigation, see Owner's Handbook for Navigation, Entertainment, Communication [6](#)
GPS positioning, vehicle position [49](#)
Ground lighting when unlocking [63](#)
Ground lighting with the vehicle locked [64](#)

H

Halogen headlights [292](#)
Handbrake, see Parking brake [112](#)

- Hands-free system, see Owner's Handbook for Navigation, Entertainment, Communication [6](#)
- Hazard warning lights [300](#)
- Head airbag [152](#)
- Head Light, adaptive [147](#)
- Headlight flasher [115](#)
- Headlight flasher, replacing the lamps [293](#)
- Headlight lens [291](#)
- Headlights [292](#)
- Headlights, care [310](#)
- Headliner [35](#)
- Head restraints and seats [84](#)
- Head-Up Display [142](#)
- Head-Up Display, care [312](#)
- Head-Up Display, saving position, see Memory function [93](#)
- Heavy transported loads, stowing [232](#)
- Height, vehicle [314](#)
- Help in case of a breakdown [300](#)
- Help in driving off, see Drive-off assistant [179](#)
- High beam assistant [148](#)
- High-beam headlights [115](#)
- High-beam headlights, replacing the lamps [293](#)
- Hill Start Assist, see Drive-off assistant [179](#)
- Holder for beverages [223](#)
- Home lights [146](#)
- Home page, see Internet [6](#)
- Horn [32](#)
- Hot exhaust system [227](#)
- HUD Head-Up Display [142](#)
- I**
- iBrake – PostCrash [174](#)
- Ice warning, see Outside temperature warning [133](#)
- Identification number, see Vehicle identification number [15](#)
- iDrive [36](#)
- Ignition off [107](#)
- Ignition on [107](#)
- Important considerations [97](#)
- Indicator and warning lamps, see Check Control [128](#)
- Indicator lamp, front passenger airbags [155](#)
- Indicator lamps, see Check Control [128](#)
- Indicators, see Turn indicators [114](#)
- Individual air distribution [203, 206](#)
- Individual settings, see Driver profiles [74](#)
- Inductive charging, smartphone, see Wireless charging dock [213](#)
- Inflation pressure, tyres [262](#)
- Inflation pressure warning RPA, tyres [160](#)
- Information display [138](#)
- Initialising, runflat indicator RPA [161](#)
- Input, iDrive [36](#)
- Instrument cluster [128](#)
- Instrument cluster switch, see Turn indicators [114](#)
- Instrument cluster switch, see Wiper system [115](#)
- Instrument lighting [150](#)
- Integrated key [66](#)
- Integrated Owner's Handbook in the vehicle [59](#)
- Intelligent emergency call [301](#)
- Intelligent Safety [163](#)
- Intended use [8](#)
- Intensity, AUTO program [206](#)
- Interior light [150](#)
- Interior light when unlocking [63](#)
- Interior light with the vehicle locked [64](#)
- Interior mirror, external [94](#)
- Interior mirror, manual dim [95](#)
- Interior mirror with automatic anti-dazzle function [95](#)
- Interior movement detector [79](#)
- Intermittent mode [116](#)
- Internet site [6](#)
- Interval display, service requirements [134](#)
- ISOFIX, child safety seat fasteners [100](#)
- J**
- Jacking points [274](#)
- Joystick, Steptronic transmission [120](#)
- Jump-starting connection, starting aid [303](#)
- Jump starting, see Starting aid [303](#)
- K**
- Keyless Go, see Comfort Access [68](#)
- Key, mechanical [66](#)

Key, see Vehicle key [62](#)
Key switch for front passenger airbags [154](#)
Kick-down, Steptronic transmission [123](#)

L

Labelling of recommended tyres [265](#)
Lane boundary, warning [169](#)
Lane Departure Warning [169](#)
Language, setting [48](#)
Launch Control [126](#)
Lay-up, vehicle [312](#)
Leather care [311](#)
LED headlights [294](#)
LEDs, light-emitting diodes [291](#)
Left-hand traffic, light setting [150](#)
Length, vehicle [314](#)
Light-alloy wheels, care [311](#)
Light-emitting diodes, LEDs [291](#)
Lighter [210](#)
Lighting [145](#)
Lights [145](#)
Light switch [145](#)
LIM button, see Manual Speed Limiter [171](#)
List, instrument cluster, see Selection lists [138](#)
List of all notifications [50](#)
Load [231](#)
Loading position [217](#)
Loading the luggage compartment, see Stowing transported loads [232](#)
Loads [231](#)
Locking, automatic [77](#)
Locking, doors and windows [106](#)
Locking, see Opening and closing [62](#)
Locking settings [76](#)
Locking wheel bolts [274](#)
Lock, power window switches, see Safety switch [80](#)
Lock, wheel bolts [274](#)
Low-beam headlights, operation [146](#)
Lower back support, see Lumbar support [86](#)
Luggage compartment [216](#)
Luggage compartment cover [216](#)
Luggage compartment, extending [217](#)
Luggage compartment separating net [219](#)

Luggage compartment, storage compartments [225](#)
Luggage rack, see Roof rack [232](#)
Lumbar support [86](#)

M

Maintenance [287](#)
Maintenance requirements, see Condition Based Service CBS [287](#)
Maintenance, service requirements [134](#)
Maintenance System, BMW [287](#)
Make-up mirror [210](#)
Malfunction displays, see Check Control [128](#)
Manual air flow [203](#)
Manual gearbox [119](#)
Manual operation, air distribution [203](#), [206](#)
Manual operation, amount of air [206](#)
Manual operation, Park Distance Control, PDC [190](#)
Manual operation, Reversing Assist camera [193](#)
Manual Speed Limiter [171](#)
Map update, see Owner's Handbook for Navigation, Entertainment, Communication [6](#)
Matt paintwork, care [310](#)
Maximum cooling [205](#)
Maximum speed, display, see Speed Limit Info [136](#)
Maximum speed, winter tyres [266](#)
Media of the Owner's Handbook [59](#)
Medical supplies, see First-aid kit [300](#)
Memory function [93](#)
Menu, instrument cluster, see Selection lists [138](#)
Menus [40](#)
Messages, see Check Control [128](#)
Methyl ester, see Diesel [257](#)
Microfilter [203](#), [207](#)
Minimum tread depth, tyres [264](#)
Mirror [94](#)
Mirror adjustment call up [77](#)
Mirror, vanity [210](#)
Mobile communication in the vehicle [228](#)
Mobile phone, see Owner's Handbook for Navigation, Entertainment, Communication [6](#)

- Mobile Service, see BMW Roadside Assistance [300](#)
- Mobile telephone, connecting [52](#)
- Mobile telephone, see Owner's Handbook for Navigation, Entertainment, Communication [6](#)
- Mobility System [267](#)
- Mode, ECO PRO [246](#)
- Moisture in the headlight [291](#)
- Monitor, see Control display [38](#)
- Mounting child restraints [98](#)
- MP3 player, see Owner's Handbook for Navigation, Entertainment, Communication [6](#)
- Multifunction steering wheel, buttons [32](#)
- Multimedia, see Owner's Handbook for Navigation, Entertainment, Communication [6](#)
- Music hard disc, see Owner's Handbook for Navigation, Entertainment, Communication [6](#)
- N**
- Navigation, see Owner's Handbook for Navigation, Entertainment, Communication [6](#)
- Net [219](#)
- Neutral cleaner, see Light-alloy wheels, care [311](#)
- New wheels and tyres [265](#)
- No Passing Information, see Speed Limit Info [136](#)
- Notes [6](#)
- Notifications [50](#)
- O**
- OBD, see On-board diagnosis, OBD [288](#)
- Obstacle marker, Reversing Assist camera [194](#)
- Octane number, see Petrol grade [256](#)
- Odometer [133](#)
- Oil [281](#)
- Oil change [284](#)
- Oil change interval, service requirements [134](#)
- Oil filler neck [282](#)
- Oil grades for topping up, engine [283](#)
- Oil, topping up [282](#)
- On-board computer [138](#)
- On-board diagnosis, OBD [288](#)
- On-board literature, printed [59](#)
- On-board monitor, see Control display [38](#)
- On-board tool kit [290](#)
- Opening and closing [62](#)
- Operating a smartphone via voice control [46](#)
- Operating menus, iDrive [36](#)
- Operating principle, iDrive [36](#)
- Operation by touchscreen [41](#)
- Operation via Controller [40](#)
- Operation via iDrive [40](#)
- Operation via voice control [44](#)
- Optimum shift indicator [136](#)
- Optional equipment, see Vehicle equipment [7](#)
- Outlets, see Ventilation [207](#)
- Outside air, see Automatic air recirculation control [206](#)
- Outside temperature display [133](#)
- Outside temperature warning [133](#)
- Overtaking restrictions [136](#)
- Owner's Handbook, printed [59](#)
- P**
- Paintwork, vehicle care [310](#)
- Pairing a device, see Registering a device [52](#)
- Panoramic glass sunroof [81](#)
- Park Assist [196](#)
- Park Distance Control PDC [189](#)
- Parked vehicle, condensation [229](#)
- Parking aid, see PDC [189](#)
- Parking assistant [196](#)
- Parking brake [112](#)
- Parking lights [146](#)
- Parking lock, unlocking manually [125](#)
- Particle filter, see Exhaust gas particle filter [227](#)
- Part replacement [290](#)
- Parts and accessories [9](#)
- Payload, technical data [315](#)
- PDC Park Distance Control [189](#)
- Pedestrian protection, active [155](#)
- Performance Control [177](#)
- Personal data, deleting [51](#)
- Personal profile, see Driver profiles [74](#)
- Person warning with city braking function [167](#)
- Petrol [256](#)
- Petrol grade [256](#)
- Petrol particle filter, see Exhaust gas particle filter [227](#)

- Place for children [97](#)
Plastic, care [311](#)
Positioning, vehicle position [49](#)
PostCrash – iBrake [174](#)
Power failure [298](#)
Power window switches [79](#)
Pressure check, tyres [156](#)
Pressure, tyres [262](#)
Pressure warning RPA, tyres [160](#)
Printed on-board literature [59](#)
Profiles, see Driver profiles [74](#)
Protection function, glass sunroof, see Anti-trap mechanism [82](#)
Protection function, windows, see Anti-trap mechanism [80](#)
- ## R
- Racetrack driving [230](#)
Radiator fan, see Exhaust gas particle filter [227](#)
Radio-ready state [108](#)
Radio, see Owner's Handbook for Navigation, Entertainment, Communication [6](#)
Radio signals [228](#)
Rain sensor [116](#)
Range [133](#)
Rapeseed methyl ester RME, see Diesel [257](#)
Rear fog light [149](#)
Rear head rests [92](#)
Rear light [294](#)
Rear lights [294](#)
Rear luggage rack [233](#)
Rear neck supports, see Rear head rests [92](#)
Rear seat backrests, folding down [217](#)
Rear seats [87](#)
Rear view mirror [94](#)
Rear window heating [203](#), [207](#)
Rear wiper, operation [117](#)
Recirculated-air mode [202](#)
Recirculating air filter, see Microfilter/active carbon filter [207](#)
Recirculation, see Recirculated-air mode [202](#)
Recommended makes of tyre [265](#)
Recycling, vehicle [289](#)
Refuelling [254](#)
Registering a device [52](#)
Remaining distance [133](#)
Remote control for audio, see Owner's Handbook for Navigation, Entertainment, Communication [6](#)
Remote control, see Vehicle key [62](#)
Remote services, app, see Owner's Handbook for Navigation, Entertainment, Communication [6](#)
Replacement of parts [290](#)
Replacement, wheels and tyres [265](#)
Replacement wheel, see Emergency wheel [276](#)
Replacing bulbs [291](#)
Replacing parts [290](#)
Replacing the bulbs, rear [294](#)
Replacing the lamps, front [292](#)
Replacing the lights, front [292](#)
Replacing the lights, rear [294](#)
Replacing the wiper blades [290](#)
RES CNCL button, camera-based cruise control, ACC [180](#)
RES CNCL button, cruise control [186](#)
Reserve warning, see Range [133](#)
Resetting, Tyre Pressure Monitor TPM [157](#)
Reset, Tyre Pressure Monitor TPM [157](#)
Restraint systems for children [97](#)
Retreaded tyres [265](#)
Reversing Assist camera [192](#)
Revolution counter [132](#)
Right-hand traffic, light setting [150](#)
RME rapeseed methyl ester, see Diesel [257](#)
Roadside Assistance, see BMW Roadside Assistance [300](#)
Rolling away in idle, see Coasting [250](#)
RON, petrol grade [256](#)
Roof load, permitted [315](#)
Roof rack [232](#)
Route-ahead assistant [249](#)
Route, navigation, see Owner's Handbook for Navigation, Entertainment, Communication [6](#)
RPA flat tyre monitor [160](#)
RTTI, see Owner's Handbook for Navigation, Entertainment, Communication [6](#)
Rubber parts, care [311](#)
Run-flat tyres [266](#)
Running in [226](#)
Running in brake discs [226](#)

Running in brake pads [226](#)
Run-on of fan, see Exhaust gas particle filter [227](#)

S

Safe seating position [84](#)
Safety switch, windows [80](#)
Safety systems, see Airbags [152](#)
Saving fuel [245](#)
Saving mirror position, see Memory function [93](#)
Saving seat position, see Memory function [93](#)
Screen, see Control display [38](#)
Screwdriver, see On-board tool kit [290](#)
Sealant, see Mobility System [267](#)
Seat adjustment call up [77](#)
Seat belt reminder for driver and front passenger seat [90](#)
Seat belt reminder for rear seats [91](#)
Seat belts [88](#)
Seat belts, care [312](#)
Seat heating, front [87](#)
Seats and head restraints [84](#)
Seats, front [84](#)
Seats, rear [87](#)
Securing, transported loads [232](#)
Selection list in the instrument cluster [138](#)
Selector lever, Steptronic transmission [120](#)
Sensors, care [312](#)
Service history [135](#)
Service requirements, display [134](#)
Service requirements, see Condition Based Service CBS [287](#)
Services, ConnectedDrive, see Owner's Handbook for Navigation, Entertainment, Communication [6](#)
Service, see BMW Roadside Assistance [300](#)
Servotronic [177](#)
Setting, control display [49](#)
Settings, general [48](#)
Settings, locking/unlocking [76](#)
Settings, mirror [94](#)
Settings, seats and head restraints [84](#)
Settings, steering wheel [96](#)
Shift paddles on the steering wheel [125](#)
Side airbag [152](#)
Side lights [145](#)
Side nozzles, see Ventilation [207](#)
Signal horn, horn [32](#)
Signals on unlocking [77](#)
Sizes, see Dimensions [314](#)
Ski and snowboard bag [220](#)
Sliding/tilting roof [81](#)
Smallest turning radius, vehicle [314](#)
Smartphone, connecting [52](#)
Smartphone, see Owner's Handbook for Navigation, Entertainment, Communication [6](#)
SMS, see Short messages, see Owner's Handbook for Navigation, Entertainment, Communication [6](#)
Snow chains [271](#)
Socket, on-board diagnosis, OBD [288](#)
Sockets, electrical devices [211](#)
Software update [58](#)
Software, updating [58](#)
Soot particle filter, see Exhaust gas particle filter [227](#)
SOS button [301](#)
Sound output, see Owner's Handbook for Navigation, Entertainment, Communication [6](#)
Sound, see Owner's Handbook for Navigation, Entertainment, Communication [6](#)
Spanner, see On-board tool kit [290](#)
Spare wheel, see Emergency wheel [276](#)
Speech recognition [44](#)
Speed Limit Device, see Manual Speed Limiter [171](#)
Speed limit, display, see Speed Limit Info [136](#)
Speed limiter, manual [171](#)
Speed Limit Info [136](#)
Speed limit, see Manual Speed Limiter [171](#)
Speed, see Average speed [139](#)
Speed warning [141](#)
Split screen [37](#)
Split screen view, split screen [37](#)
SPORT program, driving dynamics [178](#)
Sports displays [141](#)
Sport steering, variable [177](#)
Stability control systems [175](#)
Standard equipment, see Vehicle equipment [7](#)
Start/Stop button [107](#)
Starting aid [303](#)
Starting assistance, see DSC [175](#)

Starting, see Engine start [108](#)
Starting the engine [108](#)
Stations, AM/FM, see Owner's Handbook for Navigation, Entertainment, Communication [6](#)
Status indicator, tyres [157](#)
Status information, iDrive [37](#)
Status of the Owner's Handbook [7](#)
Status, vehicle [144](#)
Steering assistance [177](#)
Steering column adjustment [96](#)
Steering wheel, buttons [32](#)
Steering wheel heating [96](#)
Steering wheel, setting [96](#)
Steptronic sport transmission, see Steptronic transmission [120](#)
Steptronic sport transmission with double clutch, see Steptronic transmission [120](#)
Steptronic transmission [120](#)
Steptronic transmission with double clutch, see Steptronic transmission [120](#)
Stopping the engine [109](#)
Storage compartment in the centre console [222](#)
Storage compartment in the rear [223](#)
Storage compartments [221](#)
Storage facilities [221](#)
Storage, see Vehicle lay-up [312](#)
Storage, tyres [266](#)
Stowing, transported loads [232](#)
Suitable devices [52](#)
Suitable mobile telephones [52](#)
Summer tyres, tread [263](#)
Sun visor [210](#)
Supplementary Owner's Handbook [59](#)
Supplementary text message [132](#)
Swinging of the trailer, see Trailer Stability Control [240](#)
Switches, see Vehicle cockpit [32](#)
Switch for driving dynamics, see Driving Experience Control [177](#)
Switching off the engine [109](#)
Switch-on times, independent ventilation [208](#)
Symbols [7](#)
Symbols used [7](#)
SYNC program, automatic air conditioning [207](#)

T

Table, see Fold-down table, rear [215](#)
Tailgate, automatic [72](#)
Tailgate, closing contactlessly [69](#)
Tailgate, opening [72](#)
Tailgate, opening contactlessly [69](#)
Tailgate via vehicle key [64](#)
Tail lights [294](#)
Tank display [132](#)
Technical changes, see Your own safety [8](#)
Technical data [314](#)
Telephone, connecting [52](#)
Telephone, see Owner's Handbook for Navigation, Entertainment, Communication [6](#)
Teleservices, see Owner's Handbook for Navigation, Entertainment, Communication [6](#)
Television, TV, see Owner's Handbook for Navigation, Entertainment, Communication [6](#)
Temperature, air conditioning [202](#)
Temperature, automatic air conditioning [204](#)
Temperature display, outside temperature [133](#)
Temperature, engine [140](#)
Text message, Check Control [132](#)
Thigh support [86](#)
Third-party providers, voice assistant [46](#)
Tilt alarm sensor [79](#)
Tilting down the front passenger's side exterior mirror, see Automatic parking function [95](#)
Time [48](#)
Tool [290](#)
Total weight, permitted [315](#)
Total weight, trailer operation [319](#)
Touchscreen [41](#)
Tourist function, see Right-hand/left-hand traffic [150](#)
Towing a trailer [238](#)
Towing a trailer, technical data [319](#)
Towing away [304](#)
Towing, see Tow-starting and towing [304](#)
Tow-starting [304](#)
TPM Tyre Pressure Monitor [156](#)
Traction control [176](#)
TRACTION, driving dynamics [176](#)
Traffic information, see Owner's Handbook for Navigation, Entertainment, Communication [6](#)

Trailer loads [319](#)
Trailer nose weight, technical data [319](#)
Trailer Stability Control [240](#)
Trailer tow hitch [241](#)
Trailer tow hitch, care [312](#)
Transmission lockout, unlocking electronically [126](#)
Transported loads, stowing and securing [232](#)
Tread, tyres [263](#)
Trip computer [140](#)
Trip distance recorder [133](#)
Triple turn signal [114](#)
Turn indicator, indicator lamp [131](#)
Turn indicator rear, replacing the bulbs [294](#)
Turn indicator, replacing the bulbs, halogen headlights [292](#)
Turn indicators, operation [114](#)
Turning circle lines, Reversing Assist camera [194](#)
Turning radius, vehicle [314](#)
TV, see Owner's Handbook for Navigation, Entertainment, Communication [6](#)
Tyre damage [264](#)
Tyre inflation pressure [262](#)
Tyre inflation pressure monitor, TPM [156](#)
Tyre makes, recommendation [265](#)
Tyre pressure [262](#)
Tyre pressure monitoring, see RPA [160](#)
Tyre Pressure Monitor TPM [156](#)
Tyre repair kit, see Mobility System [267](#)
Tyre replacement [265](#)
Tyres [262](#)
Tyre sealant, see Mobility System [267](#)
Tyres with emergency running properties [266](#)
Tyre tread [263](#)

U

Units of measure [49](#)
Units, see Units of measure [49](#)
Unloaded weight [315](#)
Unlock-button, Steptronic transmission [120](#)
Unlocking, automatic [77](#)
Unlocking, see Opening and closing [62](#)
Unlocking, settings [76](#)
Updates after going to press [7](#)

Update, software [58](#)
Upholstery care [311](#)
Upper retaining strap, top tether [101](#)
USB connection [55](#)
USB interface, see USB port [212](#)
USB port, general information [212](#)
Use, intended [8](#)

V

Vanity mirror [210](#)
Variable sport steering [177](#)
Vehicle battery [296](#)
Vehicle breakdown, see Help in case of a breakdown [300](#)
Vehicle care [310](#)
Vehicle cockpit [32](#)
Vehicle data and data protection [9](#)
Vehicle equipment [7](#)
Vehicle identification number [15](#)
Vehicle key, additional [65](#)
Vehicle key, changing batteries [65](#)
Vehicle key, integrated key [66](#)
Vehicle key, loss [65](#)
Vehicle key, malfunction [65](#)
Vehicle key, opening/closing [62](#)
Vehicle lay-up [312](#)
Vehicle paintwork, care [310](#)
Vehicle position, vehicle tracking [49](#)
Vehicle, running in [226](#)
Vehicle status [144](#)
Vehicle wash [309](#)
Ventilation [207](#)
Ventilation, see Auxiliary ventilation [208](#)
Video, see Owner's Handbook for Navigation, Entertainment, Communication [6](#)
VIN, see Vehicle identification number [15](#)
Voice assistant, third-party providers [46](#)
Voice control [44](#)
Voice control system [44](#)
Voice input [44](#)

W

Warning and indicator lamps, see Check Control [128](#)

Warning indicators, see Check Control [128](#)
Warning messages, see Check Control [128](#)
Warnings, false [79](#)
Warning triangle [300](#)
Warranty [8](#)
Washer fluid [118](#)
Washer jets, windows [117](#)
Washing fluid, see Washer fluid [118](#)
Wash, vehicle [309](#)
Water on streets [228](#)
Weights [315](#)
Welcome lights [146](#)
Welcome light when unlocking [63](#)
Wheelbase, vehicle [314](#)
Wheel change [272](#)
Wheel replacement [265](#)
Wheels [262](#)
Width, vehicle [314](#)
Windscreen washer jets [117](#)
Windscreen washing system, see Wiper system [115](#)
Windscreen wipers, see Wiper system [115](#)
Winter storage, see Vehicle lay-up [312](#)
Winter tyres, right tyres [265](#)
Winter tyres, tread [264](#)
Wiper, fold-out position [117](#)
Wipers, see Wiper system [115](#)
Wiper system [115](#)
Wiping fluid, see Washer fluid [118](#)
Wireless charging dock for smartphones [213](#)
Wireless charging, smartphone, see Wireless charging dock [213](#)
Wood, care [311](#)
Wordmatch principle, navigation [36](#)
Working in, engine compartment [279](#)

X

xDrive [177](#)

Y

Your own safety [8](#)



01405A2CA68 en



The Ultimate
Driving Machine



BMW DRIVER'S GUIDE APP.

Your customised vehicle information in an app.
Optimised for smartphones & tablets. Can be used offline.



Download on the
App Store



GET IT ON
Google Play



01405A2CA68 en

Online Edition for Part no. 01405A2CA68 - II/21