



ASTON MARTIN

***RAPIDE***

## Aston Martin Owner's Club

### An invitation to join the Aston Martin Owner's Club

The sporting spirit of the 1930s exists today in one of the world's most exclusive car clubs. Enthusiasts in nearly 60 countries are united by an interest in iconic cars with an enviable pedigree. Enjoy the company of like-minded owners in a wide range of activities: social evenings, weekends away or motoring tours. Something more competitive? AMOC Concours are a benchmark for connoisseurs of fine motorcars. A need for speed? We organise track days, sprints and hill climbs as well as circuit racing in venues such as Silverstone, Goodwood and Lime Rock in the USA.



Mirroring Club activity, the Aston Martin Heritage Trust is an educational charity dedicated to the history of the marque from the earliest days almost a century ago. It shares the magnificent 15thC Oxfordshire barn which is the international headquarters, museum and archive. Why not log onto our website to discover more about these unique organisations, and enjoy a hearty welcome from us all.



The Aston Martin Owners Club  
Drayton St. Leonard,  
Wallingford,  
Oxford,  
England,  
OX10 7BG

Telephone: +44 (0) 1865 400 400

Facsimile: +44 (0) 1865 400 200

E-Mail: [hqstaff@amoc.org](mailto:hqstaff@amoc.org)

Website: [www.amoc.org](http://www.amoc.org)



Introduction .....	1
Vehicle Security.....	2
Before Driving.....	3
Controls .....	4
Driving.....	5
Climate Control.....	6
Audio.....	7
Rear Seat Entertainment .....	8
Hands-Free Phone.....	9
Satellite Navigation.....	10
Maintenance .....	11
Specifications .....	12
Service .....	A
Aston Martin Assistance .....	B
Aston Martin Warranty .....	C
Authorised Body Repairers .....	D
Authorised Service Centres.....	E
Dealer Directory.....	F

Every effort has been made to make sure that the information provided in this Owner's Guide is accurate and up-to-date. However neither the manufacturer or the Dealer, by whom this Owner's Guide is supplied, will in any circumstances be held responsible for any inaccuracy or the consequences thereof. All rights reserved.

No part of this publication may be reproduced, stored in a retrieval system or transmitted, in any form, electronic, mechanical, photocopying, recording or other means without prior written permission from Aston Martin Lagonda Limited.

The manufacturer reserves the right to vary specifications without notice in accordance with its policy of continual product improvement.

Produced by the Technical Publications Department  
 ASTON MARTIN LAGONDA LIMITED  
 Banbury Road  
 Gaydon  
 WARWICK  
 Warwickshire  
 CV35 0DB  
 England  
 Telephone: (+44) 01926 644300  
 Fax: (+44) 01926 644733

Issue 3 – January 2011  
 Part Number – AD43-19A321-AD

# Introduction

Welcome .....	1.2
Warnings, Cautions and Notes .....	1.2
Component Location .....	1.2
Vehicle Identification .....	1.3
Data Recording .....	1.3
Reporting Safety Defects .....	1.4
Vehicle Provenance .....	1.4



ASTON MARTIN

**RAPIDE**

Hand built for The Frankfurt Motorshow 2009

## Welcome

to your new Aston Martin.

This Owner's Guide, along with other publications included in your literature pack, provides information which will enhance your pleasure from owning and driving your Aston Martin.

This Owner's Guide has been designed to explain the vehicle's operation and to make the control of its systems easy to understand and operate. All new owners are recommended to carefully study the contents of this Owner's Guide prior to driving.

This Owner's Guide forms part of the essential vehicle equipment for homologation purposes and must stay with the vehicle at all times.

To further assist the driver a location guide is located on the passenger side 'A' panel. This is a quick reference guide to show the location of the major items on the vehicle.

## Warnings, Cautions and Notes

The following Warnings, Cautions and Notes are used within this Owner's Guide to call your attention to specific types of information.

### Warnings

**⚠ Warning: Provided to show procedures which must be followed precisely to help avoid the risk of personal injury.**

### Cautions

**⚠ Provided to show procedures which must be followed precisely to reduce the possibility of damage to your vehicle.**

### Notes

**📖 Provided to show procedures which will help to avoid difficulties in the operation of your vehicle.**

## Component Location

All directions for locating components are described as viewed from the driver's seat, i.e. the fuel filler flap shown on this diagram will be described as 'located at the rear left side of the vehicle'.

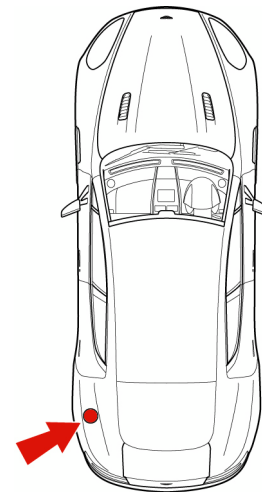

## Vehicle Identification

The Vehicle Identification Number (VIN) is shown in the left side bottom corner of the windscreen.

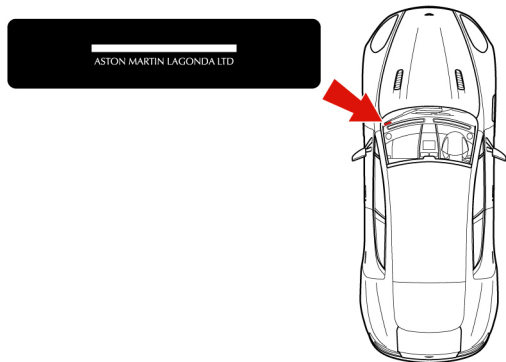

The VIN Plate, attached to the front subframe behind the engine bay front cross member (viewed from above), is model and market dependent:

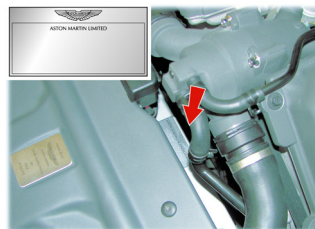

The vehicle identification number is also stamped into the floorpan in the right side footwell.

 *To view the VIN stamped into the floorpan lift the carpet up, from the front, and then lift the sound deadening material.*

## Data Recording

Computers in your vehicle are capable of recording detailed data, potentially including but not limited to information such as:

- The use of restraint systems including seat belts by the driver and passengers
- Information about the performance of various systems and modules in the vehicle
- Information related to engine, throttle, steering, brake or other system status

Any of this information could potentially include information regarding how the driver operates the vehicle, potentially including but not limited to information regarding vehicle speed, brake, throttle application or steering input. This information may be stored under regular operation, in a crash or near crash event.

This information may be read out and used by:

- Aston Martin
- Service and repair facilities
- Law enforcement or government agencies
- Others who may assert a right or obtain your consent to know such information

## Reporting Safety Defects

If you believe that your vehicle has a safety defect which could cause a crash or could cause injury or death, you should immediately inform your Aston Martin Dealer or the manufacturers Service Operations Department at the address shown.

Aston Martin Lagonda Limited  
Service Operations Department  
Banbury Road  
Gaydon  
WARWICK  
CV35 0DB  
England

Telephone:

(International) ++44 1926 644700  
(United Kingdom) 01926 644700  
Facsimile (+ +44) 1926 644733

## Vehicle Provenance

**Model:**

e.g. Manual, Automatic

**Body Colour:**

**Interior Colour:**

**Fascia Colour:**

**Vehicle Identification Number:**

As on the VIN plate

**First Owner:**

Selling Dealer

Delivery Date

**Second Owner:**

Selling Dealer

Delivery Date



---

**Third Owner:**

---

Selling Dealer

---

---

Delivery Date

---

---

**Fourth Owner:**

---

Selling Dealer

---

---

Delivery Date

---

---

**Fifth Owner:**

---

Selling Dealer

---

---

Delivery Date

---

---

**Sixth Owner:**

---

Selling Dealer

---

---

Delivery Date

---



ASTON MARTIN



ASTON MARTIN



ASTON MARTIN



ASTON MARTIN

# Vehicle Security

Introduction .....	2.2	Deadlocking .....	2.8
Aston Martin Tracking .....	2.2	Automatic Lock .....	2.8
Emotion Control Unit .....	2.3	Approach Light .....	2.9
Unlocking and Opening .....	2.4	Homesafe .....	2.9
Locking .....	2.5	Alarm .....	2.10
Master Locks .....	2.5	Reduced Guard .....	2.10
Fuel Flap Release .....	2.6	Passive Anti-Theft System .....	2.11
Boot Lid .....	2.7	Garage Door Opener .....	2.12
		Personalisation .....	2.15

## Introduction

This vehicle is protected by electronic security system which includes:

- Remote arm and disarm
- Perimeter sensing
- Remote door, boot lid, fuel flap release lock and unlock
- Guard reduction mode
- Alarm siren with battery backup<sup>1</sup>
- Random code encryption to prevent electronic scanning or grabbing of the vehicle key identity code
- Interior movement sensor<sup>2</sup>
- Tilt Sensor<sup>2</sup>.

Vehicle protection is enhanced by a Passive Anti-Theft System (PATS) which provides engine immobilisation if the wrong vehicle key is used.

When the security system is armed, any attempt to forcibly open a door, the boot lid or the bonnet will result in full alarm operation.

## Garage Door Opener

(Option)

As a security precaution make sure that all programming is erased in the HomeLink system before selling this vehicle (Refer to 'Garage Door Opener', page 2.12).

## Aston Martin Tracking

(Option (Not Available in all Markets))

(Standard - Mainland UK)

The Aston Martin Tracking system works like an electronic homing device, transmitting a stolen vehicle's location.

The system, which is discretely installed in the vehicle, is an easy-to-use system that provides the following important features:

- Automatically arms the security system when the vehicle key is removed and you leave the vehicle
- Detects your presence (using a driver recognition tag) and automatically disarms the system when you return

 A convenient storage location for the driver recognition tag is provided in the armrest cubby box lid.

- Detects attempts to start the vehicle without you being there
- Detects attempts to tow or move the vehicle
- Detects attempts to tamper with the tracking system or disconnect the vehicle battery
- Transmits silent alarms to the 24-hour monitoring service
- Gives you priority access to police in more than 30 countries
- Meets all insurance requirements

---

<sup>1</sup> Markets where audible sirens are permitted.

<sup>2</sup> Option.

## Emotion Control Unit

Refer to the Aston Martin Tracking User Guide for operating instructions.

Please consult your Aston Martin Dealer for details and subscription rates.

 Do not keep the Aston Martin Tracking User Guide in the vehicle otherwise you will not be able to refer to it if your vehicle is stolen.

 Tracking systems place extra demands on vehicle power while set to ON. This will reduce vehicle battery stand-by time (Refer to 'Vehicle Battery Charge', page 11.20).

### Tag Warning

If the driver recognition tag is not in range of the vehicle tracking system the PATS symbol will continue to be ON after the vehicle has started. If this happens stop the engine, remove the vehicle key from the ignition control and check the location of the recognition tag.

Refer to your Aston Martin Tracking User Guidebook.

The vehicle is supplied with three vehicle keys<sup>1</sup> (Emotion Control Units), a glass key, a spare key and an emergency key.



Keep the spare key in a safe place. Do not leave a vehicle key in the vehicle when unattended.

 If a vehicle key is lost, contact your Aston Martin Dealer.

<sup>1</sup>. Manufactured by  STRATTEC. 8D33-70290-BG.

## Vehicle Key Security Functions

**[1] LOCK** - Press and release for one step vehicle locking and to arm the security system. The front seats and door rear view mirror positions are memorised. The vehicle will deadlock after 25 seconds. Press and hold to raise the door windows at the same time.

(Refer to 'Deadlocking', page 2.8)

**[2] UNLOCK** - Press and release for one step vehicle unlocking. Press and hold to lower the door windows at the same time.

(Refer to 'Unlocking and Opening', page 2.4)

(Refer to 'Seat Memory Function', page 3.5)

**[3] BOOT OPEN** - Press once to release the boot lid catch (Refer to 'Boot Lid', page 2.7).

**[4] APPROACH LIGHT** - Press to set the front, rear side and interior lamps to ON (Refer to 'Approach Light', page 2.9).



## Unlocking and Opening

Stand within 5 m of the vehicle, point the vehicle key towards the vehicle and press the  button. To show that the security system has been disarmed, the direction indicators will flash twice. All vehicle doors will unlock. The boot lid catch and fuel flap release button will be enabled.

Push at point A and grab the emerging door release. Pull the door release to open the door.

If a door is opened while driving a warning sound will be heard until the door is closed.

 If preferred you can unlock the drivers door only with the first press of the button and the rest of the vehicle with a second press (Refer to 'Personalisation', page 2.15).

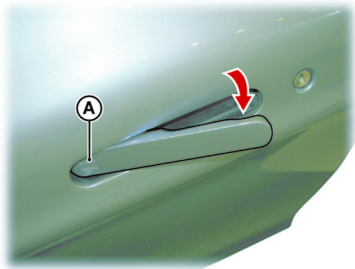

 For ease of use at night white LEDs are incorporated into the door handles. An LED will come ON in the door handles when the vehicle is unlocked. A door LED will go OFF once the door is opened. If a door is not opened the LEDs will go OFF after two minutes.

 If the vehicle has been opened using the spare key and the seats or door rear view mirrors have been adjusted, the seats and door rear view mirrors will move to the positions memorised by the key which is being used (Refer to 'Seat Memory Function', page 3.5).

 As the vehicle is unlocked, the interior lamps will come ON for five minutes. The lamps will go OFF 30 seconds after doors are closed or when the vehicle is started.

 If the door is left open the door puddle lamp will go OFF after eight minutes.

### Unlocking From Inside the Vehicle

 **If reduced guard was not set to ON before locking the vehicle, deadlocking, interior movement and tilt sensors<sub>1</sub> are enabled. Passengers will not be able to unlock a door from the inside.**

<sub>1</sub>. Option.

If reduced guard or automatic lock was set to ON before the vehicle was locked, one pull of a door handle will centrally unlock the doors, a second pull of the door handle will open that door.

(Refer to 'Automatic Lock', page 2.8).

(Refer to 'Reduced Guard', page 2.10).

 Vehicle unlock from inside can be set to automatic unlock when the vehicle key is removed from the ignition control. With automatic unlock ON only one pull of a door handle will open that door (Refer to 'Personalisation', page 2.15).

When opening a door from inside the vehicle after reduced guard has been set to ON, the security system alarm will start. Press the  button on the vehicle key to stop the alarm (there is approximately a ten second delay before the alarm is stopped).

## Locking

**!** *If passengers are to stay in the vehicle after it has been locked, reduced guard must be set to ON before locking. This will let a passenger open a door from inside the vehicle.*

Make sure that all the doors, the boot lid and the bonnet are closed (the vehicle will not lock if a door is left open). Stand within 5 m of the vehicle, point the vehicle key towards the vehicle and press the

 button once to lock the doors, disable the boot lid and fuel flap release switches and arm the security system. The direction indicators will flash once as the security system is armed (Refer to 'Personalisation', page 2.15).

The front seats and both door rear view mirror positions are memorised and will be recalled the next time the vehicle is opened using the same vehicle key.

 *The security system will arm and the doors will deadlock after 25 seconds.*

 *If the vehicle is locked with the boot lid open, the vehicle will lock and arm but deadlocking, tilt and interior movement sensors<sup>1</sup> will not operate. Close the boot lid to arm the complete security system.*

<sup>1</sup>. Option.

## Automatic Re-locking

If the vehicle is locked and then unlocked but a door or the boot lid is not opened within two minutes, the vehicle will automatically lock and arm again.

## Master Locks

All doors, fuel flap and boot lid release switches may be locked and unlocked by using the front master lock switch (A). Press the switch to lock. Press again to unlock.

If the vehicle is locked using the master lock switch, one pull of a door handle will centrally unlock the doors, a second pull of the door handle will open that door.

The master lock switch will operate for seven minutes after the vehicle key has been removed from the ignition control, if the vehicle is not locked using the vehicle key.

The master lock switch will not operate if the vehicle has been locked from the outside.

Operation of the master lock switch will override automatic lock (Refer to 'Automatic Lock', page 2.8).



 When the vehicle is unlocked using the master lock switch the LED in each door handle will come ON (for 10 seconds or until the door is opened). This may aid access for passengers at night time.

 In the event of a vehicle accident the doors will automatically unlock.

### Rear Passenger Door Lock

The rear doors can be centrally locked independently from the master lock switch. Press the rear lock switch (B) to lock the rear doors.

If the rear doors are locked using the rear lock switch, one pull of a door handle will unlock that door, a second pull of a door handle will open that door.

The rear lock switch will operate for seven minutes after the vehicle key has been removed from the ignition control, if the vehicle is not locked using the vehicle key.

 In the event of a vehicle accident the doors will automatically unlock.



### Child Locks

Press **MENU** (C). Navigate to <Car settings...> (Enter) <Lock settings...> (Enter) <Child lock enabled>. Press **ENTER** to toggle between child locks ON and OFF.

 In the event of a vehicle accident the rear doors will automatically unlock.



### Fuel Flap Release

Push the fuel flap release button (A) to open the fuel flap.

The fuel flap release is disabled when the vehicle is locked or when the vehicle moves off.





## Boot Lid

### To Open the Boot Lid

Press the  button on the vehicle key once to release the boot lid catch. Lift the lid.

 *If the vehicle is locked and armed the security system will disarm and the direction indicators will flash twice when the boot is opened. The doors will stay locked (Refer to 'Personalisation', page 2.15).*

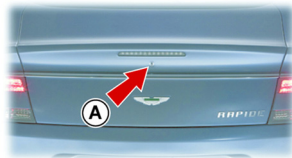

### Opening from Inside the Vehicle

Press the boot lid release switch (B). The boot lid catch will enable and release. Lift the boot lid.



### To Close the Boot Lid

Grasp the leather pull (C) and pull the boot lid down, then push the boot lid down and make sure that its catch engages.



Press the  button on the vehicle key to lock the lid. The direction indicators will flash once as the security system is armed (Refer to 'Personalisation', page 2.15).

 *Always make sure that the boot lid is securely closed after use. The boot interior lamps will stay ON for seven minutes if the boot lid is left partially open and the vehicle key is removed from the ignition control.*

### Vehicle Locked - Boot Lid Open

 *To use a battery conditioner the boot lid has to be left open (boot lid down but not latched).*

If the vehicle is locked while the boot lid is open, the vehicle will lock and arm (deadlocking, tilt and interior movement sensors<sub>1</sub> will not operate). If the boot lid is then closed (latched) deadlocking, tilt and interior movement sensors will operate and the whole vehicle will be locked and armed.

<sup>1</sup>. If installed on your vehicle.

## Boot Lid Emergency Open

The boot lid can be opened from inside the boot by pulling the luminous emergency release handle (D).



## Deadlocking

**!** *If passengers are to stay in the vehicle after locking, reduced guard must be ON before locking.*

The vehicle will automatically deadlock after 25 seconds after arming the security system. When the vehicle is deadlocked, the doors cannot be opened from the inside by pulling the interior door handle. To open the doors use the vehicle key.

## Automatic Lock

When automatic lock is set to ON the doors and the boot lid will automatically lock as vehicle speed reaches 7 km/h. This function prevents unwanted access to the vehicle when stopped at traffic lights, etc.

Press **MENU** (A). Navigate to <Car settings...> (Enter) <Lock settings...> (Enter) <Automatic settings...>. Select <Doors auto lock> or <Doors auto unlock on key out>. Press **ENTER** to toggle between ON and OFF.

Then press and hold **BACK** to accept and return to the main screen.





## Approach Light

**<Doors auto lock>** - Set to ON: Doors and the boot lid automatically lock when the vehicle moves off. Set to OFF: Doors and the boot lid will not lock when the vehicle moves off.

**<Doors auto unlock on key out>** - Set to ON: The front doors and the boot lid automatically unlock when the vehicle key is removed from the ignition control. Set to OFF: One pull of a door handle will centrally unlock all doors, a second pull of the door handle will open that door.

 *Automatic lock is factory set to ON (Refer to 'Personalisation', page 2.15).*

 *In the event of a vehicle accident all doors will automatically unlock.*

When approaching the vehicle the side and interior lamps can be set to ON by pressing the  button on the vehicle key.

The time that the lamps stay ON is programmable (Refer to 'Personalisation', page 2.15).

## Homesafe

When exiting the vehicle and the vehicle key has been removed, flash the main beam (pull the left side stalk up and release without latching) to set homesafe ON. The main beam and rear lamps will then stay ON for a determined amount of time and then go OFF. The time that the main beam and rear lamps stay ON is programmable (Refer to 'Personalisation', page 2.15).

## Alarm

When the alarm has started a siren will be heard for a 25 seconds cycle (ten cycles maximum) and the direction indicators flash for five minutes after which the security system returns to the armed state. The doors and boot lid will stay locked throughout.

 Markets where visible alarm signals and audible sirens are permitted.

Stop the alarm at any time by pressing the  button on the vehicle key or by inserting the vehicle key into the ignition control (position 'II'). There is approximately a ten second delay before the alarm is stopped).

 Insert the key to position 'II' by using the flat of a finger, as shown.

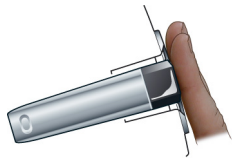

## Interior Movement Sensor

(Option)

When the vehicle is locked and armed the interior movement sensor will sense movement inside the vehicle. If movement is detected it will start the alarm.

## Tilt Sensor

(Option)

When the vehicle is locked and armed the tilt sensor will sense if the vehicle is tilted, for example, if the vehicle is being raised on a jack. If vehicle tilt is detected it will start the alarm.

## Reduced Guard

 **Warning: If a passenger is to stay in the vehicle after it has been locked, reduced guard must be set to ON before locking. In an emergency this will let a passenger open a door from inside the vehicle.**

When reduced guard is ON deadlocking, interior movement and tilt sensors<sub>1</sub> are set to OFF. This will let a passenger open a door from the inside by pulling the interior door handle and a passenger or animals to be left in the vehicle with the security system armed.

If a door is opened from the inside, while reduced guard is ON, the security system alarm will start.

Press the  button on the vehicle key to stop the alarm at any time.

---

<sup>1</sup>. Option

## Passive Anti-Theft System

Reduced guard is set by using the car settings menu. Press **MENU** (A). Navigate to <Car settings...> (Enter) <Reduced guard...>. Select <Activate once> or <Ask on exit> and press **ENTER** to toggle between ON and OFF. Then press and hold **BACK** to accept and return to the main screen.

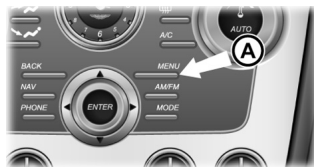

**<Ask on exit>** - Set to ON: Each time the vehicle key is moved from ignition position 'II' (ignition ON) to ignition position 'I' or '0' the message PRESS ENTER TO REDUCE GUARD. PRESS EXIT TO CANCEL will show in the message centre (right). The message will time out after one minute and reduced guard will not come ON. Set to OFF: No message will show and reduced guard will not come ON.

**<Activate once>** - Set to ON: Reduced guard will come ON for one time. Set to ON each time reduced guard is required. Set to OFF: Reduced guard will not come ON.

Reduced guard stays ON until the vehicle key is inserted in the ignition control and moved to position 'II' (ignition ON).

The Passive Anti-Theft System (PATS) is a fully automatic engine immobiliser.

 *If a vehicle key is lost, a duplicate key can be created and programmed from the spare key by your Aston Martin Dealer.*

### Starting the Engine

When the security system is disarmed and the vehicle key is in the ignition control, the PATS controller sends a signal to the vehicle key. The vehicle key must respond with a valid code before engine start will be enabled. If a valid code is received, the ignition system will operate normally. If the vehicle key code is not received, or is invalid, engine start stays disabled.

### PATS Status

The PATS system state is shown by the red symbol on the instrument cluster (A).



#### Ignition

ON  
OFF  
OFF and the vehicle key removed from the ignition control

#### Action (Valid code)

Symbol comes ON for three seconds.  
Symbol will flash.  
Symbol will flash for five minutes or one minute after the vehicle is locked using the vehicle key.

### Fault Mode

If the status symbol continues flashing when the ignition is set to ON, the vehicle will stay immobilised.

## Garage Door Opener

Should this situation arise try removing and then inserting the vehicle key back to position 'II' in the ignition control. If this is unsuccessful try the spare key. If successful, get a replacement for the faulty vehicle key. If problems continue with the vehicle key, consult your Aston Martin Dealer.

(Option: Available with auto dimming mirror only.)

The garage door opener (Homelink® Universal Transceiver) operating buttons and transceiver are located in the interior rear view mirror.

The transceiver can be programmed to transmit the radio frequencies of up to three different transmitters used to operate garage doors, entry gates, home lights, security systems, or other radio frequency operated devices.

 A full list of radio frequency operated devices can be either obtained via the HomeLink Hot-line or through the HomeLink compatibility list which is provided on the HomeLink website.

For information, or for assistance, contact your Aston Martin Dealer. Alternatively contact Homelink directly at [www.homelink.com](http://www.homelink.com) or call the HomeLink Hot-line:

Toll-free: 008000 0466 354 65

or

+49 6838 907-277 (In certain countries difficulties may be experienced trying to reach the toll-free number by some providers).

 **Warning: Do not use the transceiver with any garage door opening system that lacks the safety stop and reverse feature as required by safety standards. A garage door opening system which cannot detect an object, signalling the door to stop and reverse, does not meet current safety standards. Using a garage door opening system without these features increases risk of serious injury or death.**

 **Warning: When programming the transceiver to a garage door opening system, make sure that people, the vehicle and objects are out of the way to prevent potential harm or damage as the gate or garage door will operate during the programming.**

 Keep the original transmitter for future use or programming procedures if, for example, you purchase a new vehicle.

 This device may suffer from interference if operated in the vicinity of a mobile or fixed station transmitter. This interference is likely to affect the hand-held transmitter as well as the in-vehicle transceiver.

 The manufacturer is not responsible for any radio or TV interference caused by unauthorised modifications to this equipment. Such modifications could void the user's authority to operate the equipment.

## Programming

 Step 1 erases all programming. It only requires completing if programming Homelink for the first time or when erasing all existing programming. It does not have to be followed to program the other HomeLink buttons.

 The HomeLink buttons can be reprogrammed individually but not individually erased. Step 1 must be completed to erase all programming.

1. Press and hold the two outer HomeLink buttons, releasing only when the HomeLink LED begins to flash after 20 seconds. All three buttons are now cleared. The HomeLink system is now in setting mode. As a security precaution make sure that all programming is erased in the HomeLink system before selling this vehicle.

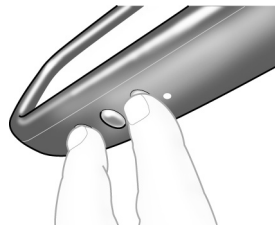

2. Hold the original remote control of the device to be programmed at a distance of 10-30 cm away from the HomeLink transmitter unit keeping the LED in view all the time. The distance between the remote control and the transmitter unit depends on the system being programmed. You may require several attempts at different distances. Maintain each setting position for at least 15 seconds before trying out another.
3. Using both hands, simultaneously push the remote control button and the desired button (1, 2 or 3).
4. The LED will flash, first slowly and then rapidly. When the LED flashes rapidly, release both buttons. The rapid flashing LED shows successful programming of the new frequency signal.



## Operation

The vehicle should be within the operating range of the gate or garage door opener and the ignition should be ON.

The HomeLink system operates the garage door opener (or other device) in exactly the same way as the original remote control.

When you have programmed the HomeLink system, press the appropriate button 1, 2, or 3 on the control panel to operate the garage door opener.

The LED will come ON when the button on the control panel is pressed.

 For convenience, the original remote control of the device may also be used at any time.

In the case of a standard code, the HomeLink LED is constantly ON throughout the transmission process. For use with compatible systems, no further action is necessary.



If HomeLink now does not operate the garage door opener (or other device), this may be because the original remote control has a rolling code feature (Refer to 'Rolling Code Synchronisation', page 2.14).

### Rolling Code Synchronisation

Check, by going through the following steps, whether or not the garage door opener (or other device) is equipped with a rolling code feature.

- Look in the garage door opener manual for clarification
- The remote control apparently programs HomeLink but HomeLink does not operate the garage door opener
- Press and hold down the programmed HomeLink button.  
With a rolling code system, the HomeLink LED flashes quickly for a short time and then stays ON constantly for two seconds. This pattern repeats itself for up to 20 seconds

If HomeLink was programmed with a rolling code system, then after the end of the programming period it must be synchronised with this system again before it will function correctly.

Follow the instructions below for Rolling Code Synchronisation (the procedure will take less time with a second person to help).

The vehicle must be within operating range of the garage door opener and the ignition set to ON. Make sure you comply with the safety instructions even when synchronising the rolling code.

1. Locate the Training button (programming button) on the garage door opener motor head unit. Exact location and colour of the button may vary by gate or garage door opener brand (refer to the operating instructions of the garage door opener 'Training additional remote controls').
2. Press the Training button (programming button) on the garage door opener motor head unit (which will usually set a 'training' LED to ON).  
Following step 2, there are typically 30 seconds in which to initiate step 3.
3. Firmly press and release the programmed HomeLink button. Press and release the HomeLink button a second time to complete the training process. (Some garage door openers may require this procedure a third time to complete the training).

The garage door opener should now recognise the HomeLink signal and operate when the HomeLink button is pressed.

The next two buttons may now be programmed if this has not previously been done (Refer to 'Programming', page 2.13).

### Reprogramming

If a HomeLink button has been programmed to operate a device, and you now wish to use this button to operate a different device, proceed as follows. This procedure will erase the existing programming of the respective HomeLink button.

1. Press the appropriate HomeLink button 1, 2, or 3 which requires reprogramming and keep holding it for about 20 seconds until the LED starts flashing slowly. Do not release until step 4 has been completed.
2. When the LED begins to flash slowly (after approximately 20 seconds), hold the remote control of the device you wish to use approximately 10-30 cm away from the HomeLink transmitter unit - keeping the LED in view.  
The distance between the remote control and the HomeLink transmitter unit depends on the system being learned. You may require several attempts at different distances. Maintain each setting position for at least 15 seconds before trying out another.
3. Now press the remote control and keep it pressed.



## Personalisation

4. The HomeLink LED will flash, first slowly and then rapidly. When the LED begins to flash rapidly, release both buttons.

A number of security functions can be personalised. The functions are set by using the Infotainment **SCREEN**.

[1] **ON/OFF** - Infotainment centre ON and OFF

[2] **SCREEN** - Shows options, menus and information.

[3] **TUNING** - Turn (left or right) to navigate in the menus.

[4] **MENU** - Opens the main menu.

[5] **ENTER** - Select in the menu or open a selection.

[6] **JOYSTICK** - Navigate up or down in the menus.

[7] **BACK** - Navigate back in the menu or cancel a selection.



## Selection

With the vehicle key in ignition position 'I' or 'II', press **MENU** and navigate to the required setting and press **ENTER**. Use the **JOYSTICK** to make a selection and press **ENTER** to accept.

## Menu

### 1) Car settings...

- 1) Reduced guard...
  - 1) Activate once
  - 2) Ask on exit
- 2) Mirror settings...
  - 1) Auto mirror fold flat enabled
  - 2) Reverse mirror dip settings...
    - 1) Auto
    - 2) Passenger only
    - 3) Passenger and driver
- 3) Lock settings...
  - 1) Automatic settings...
    - 1) Doors auto lock
    - 2) Doors auto unlock on key out
  - 2) Doors unlock...
    - 1) All doors
    - 2) Driver door, then all

### 1) Child lock enabled

- 4) Light settings...
  - 1) Lock confirm. light
  - 2) Unlock confirm. light
  - 3) Approach light duration...
    - 1) 30, 60 or 90 seconds
  - 4) Homesafe light duration...
    - 1) 30, 60 or 90 seconds
- 5) Information...
  - 1) VIN number...



ASTON MARTIN

# Before Driving

Before Driving.....	3.2	ISOFIX Anchors.....	3.17
Seat Adjustment.....	3.2	Tether Anchors .....	3.18
Temperature Controlled Seats .....	3.4	Automatic Locking Retractors.....	3.19
Seat Memory Function .....	3.5	Child Seats.....	3.20
Steering Wheel .....	3.6	Boot Storage .....	3.23
Interior Mirrors.....	3.6	Cabin Storage .....	3.24
Door Mirrors.....	3.6	Media Devices.....	3.26
Restraints System.....	3.8	Accessory Socket.....	3.27
Seat Belts .....	3.8	Ashtray and Cigar Lighter .....	3.27
Airbags.....	3.11	Electric Windows .....	3.28
Child Safety.....	3.14	Reading Lamps .....	3.30
Passenger Airbag Deactivation.....	3.16	Coat Hooks.....	3.30

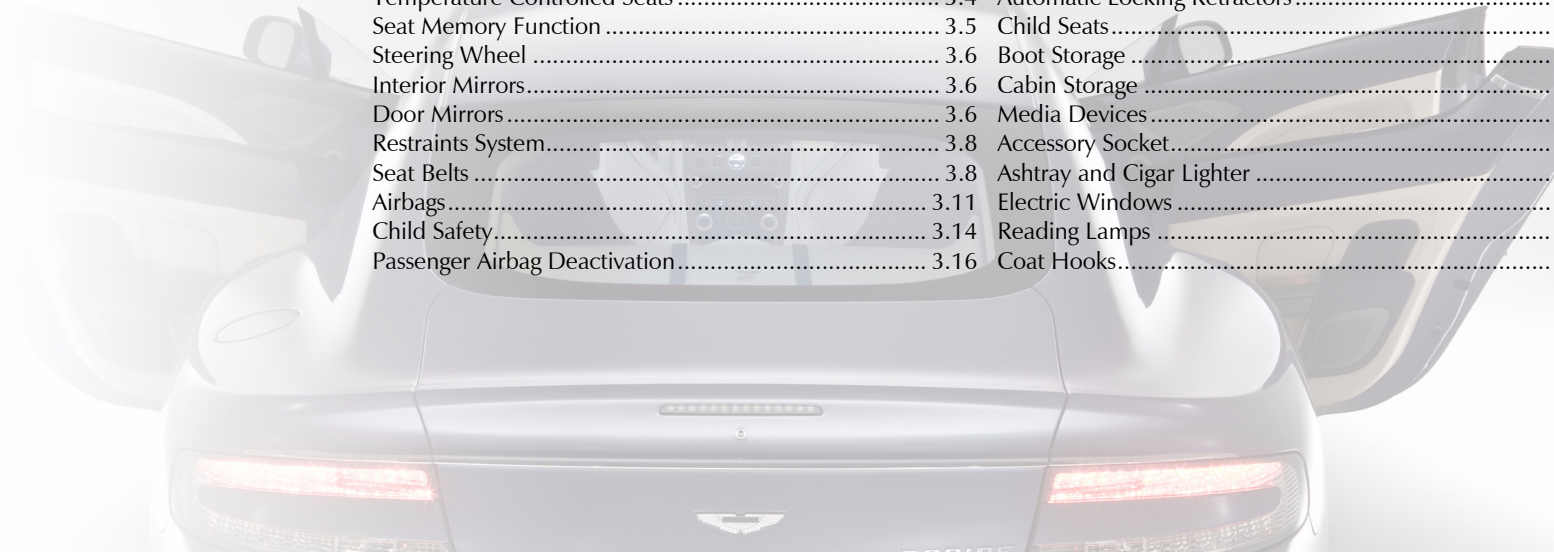

## Before Driving

### Checks Before Driving

Inspect your vehicle to make sure that everything is according to the information and specifications in this Owner's Guide.

#### Outside the vehicle:

- Visually check the road wheels, nuts and tyres
- Check that all windows, mirrors and lamps are clear and unobstructed
- Check that the boot lid, bonnet and fuel filler flap are securely closed
- Check the operation of all lamps

#### Once Inside the vehicle:

- Check that the doors are securely closed
- Check that the seat, mirrors and steering wheel adjustments are correct
- Check that all gauges and symbols are reading correctly
- Check that all passengers have fastened their seat belts

## Seat Adjustment

### Front Seats

**⚠ Warning: Do not attempt to adjust the drivers seat whilst driving.**

**! The vehicle key must only be inserted into the ignition control with the two indents first, as shown. To insert the larger end first the key may damage the ignition control.**



The front seats can be adjusted while the vehicle key is in the ignition control. Gently insert the vehicle key up to position '1' (press down until the instrument cluster and infotainment centre lights come ON) and release.

They can also be adjusted:

- Up to six minutes after a door is unlocked and before the vehicle key is inserted into the ignition control
- Up to six minutes after the vehicle key is removed from the ignition control

If the seat operation times out:

- Place the vehicle key in the ignition control
- Close or open a door

The seat adjustment controls are located each side of the centre console (A).

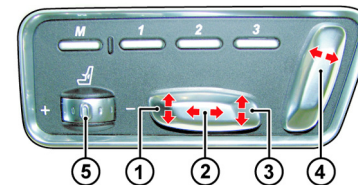

[1] - Raise or lower the **front** of the seat.

[2] - Move the seat **forwards** or **rearwards**.

[3] - Raise or lower the **rear** of the seat.

[4] - Increase or decrease the **angle of the seat back**.

[5] - Hold the thumb wheel forwards or rearwards to increase or reduce the **lumbar support**.

### Seat Head Restraints

The driver and passenger seats include non-adjustable head restraints (B), which limit the rearward travel of the head in a rear impact and may reduce whip lash injuries.

When sitting in the seats make sure that the seat back is in an upright position and that the rear of the head is positioned in the centre of the head restraint area. The head restraints are most effective when the distance between the rear of the head and the head restraint is kept to a minimum.



### Rear Seats

The rear seat back can fold down to give more boot area storage options (Refer to 'Boot Storage', page 3.23).

Press hold (half a second) and release the seat back release button (C) for each rear seat as required. Lower the seat back until level with the boot floor.

To raise lift the seat back to its upright position, take care not to trap the seat belt, and make sure that the seat back is locked into position (button LED OFF). If the button LED stays ON the seat back is not locked in place.

If the vehicle has no power a manual release is located on the outside, behind both seat backs.

The seat backs can only be released when a rear door is open and the vehicle is at a standstill.



### Grab Handle

To assist passengers in and out of the rear seats use the grab handle provided, located on both rear door pillars. A magnet holds the grab handle in place.



## Temperature Controlled Seats

The front and rear seats can be cooled<sup>1</sup> or heated. Cooled or heated air is forced through small holes in the seat base and back. Use the individual seat controls to set the seat temperature.

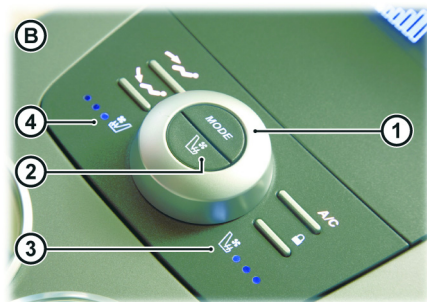
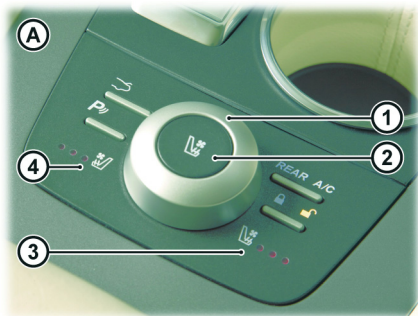

[A] - Front

[B] - Rear

[1] **DIAL** - Turn to raise or lower the seat temperature.

[2] **SEAT SELECT** - Press and release to select the left or right seat.

[3] **RIGHT SEAT** - When the symbol is ON use the **DIAL** to set the seat temperature.

[4] **LEFT SEAT** - When the symbol is ON use the **DIAL** to set the seat temperature.

### Operation

#### Front and Rear Seats

 The seats can be selected if the ignition is set to ON, but they will not operate until the engine is operating.

Press and release the **SEAT SELECT** button to select the left or right seat. The selected seat symbol will come ON.

Turn the **DIAL** clockwise to heat the seat or anticlockwise to reduce the heat. On vehicles with heated and cooled seats, turn the **DIAL** clockwise to heat and anticlockwise to cool the seat.

The selected seat LEDs show the level of heat (red LEDs) or cooling (blue LEDs). No LEDs shows that the temperature controlled seats are OFF.

Press and hold the **SEAT SELECT** button to set the temperature controlled seats to OFF (LEDs OFF). The system defaults to OFF at each ignition OFF.

<sup>1</sup> If installed on your vehicle.

## Seat Memory Function

**⚠ Warning:** Make sure that there is nothing in front of, behind, or under the seat during adjustment.

**⚠ Warning:** To avoid injury, make sure that children do not play with the switches

**⚠ Warning:** If the seat accidentally begins to move, press any seat control button to stop the seat.

The position of the driver and front passenger seats can be memorised and recalled. Three different driving position profiles can be entered in the memory. The memory position of the driver's seat also includes both door rear view mirrors.



The memory function buttons are located in the seat adjustment controls which are located each side of the centre console (A).

### Setting a Preset Position

**⚠ Warning:** Do not attempt to adjust the seat whilst driving.

Adjust the seat and the door rear view mirrors to the desired position.

- Seat adjustment (Refer to 'Seat Adjustment', page 3.2).
- Mirror adjustment (Refer to 'Door Mirrors', page 3.6).

Push both the memory button (M) and the desired setting button (1, 2 or 3) simultaneously and release. A chime is heard and message will show in the message centre (right) to confirm<sup>1</sup>.

By repeating these steps and pressing an unused button (1, 2 or 3), a second and third driving position can be stored in the memory.



**📖** When making adjustments to a set driving position, reset the new position in the same memory channel. The previous memory is erased when a new driving position is entered.

### Recalling a Memorised Position

Once in the seat press and hold button 1, 2 or 3 (depending on which position required) until all movement is stopped.

<sup>1</sup>. Driver's seat only.

The seat and door mirrors (when adjusting the driver's seat) move to the programmed position. If the button is released all movement will stop, press and hold again to continue movement.

### Memory Using the Vehicle Key

When the vehicle is locked using the vehicle key, the driver's seat and both door rear view mirrors will remember their positions. The next time the vehicle is opened using the same vehicle key, the seat and door rear view mirrors will move to the memorised position once the door handle is used.

**📖** The seats and door rear view mirrors only move if they have been moved previously, i.e. the spare vehicle key has been used and the seats or mirrors have been moved.

### Emergency Stop

If the seat accidentally begins to move, press any seat control button to stop the seat.

## Steering Wheel

**⚠ Warning:** Do not adjust steering wheel whilst driving.

**⚠ Warning:** Make sure that the steering column is fully locked in position. The reach and tilt release lever must be fully up, in line with the steering column.

### Reach and Tilt

The reach and tilt angle of the steering wheel are adjusted by using the release lever (A). Pull the release lever downwards and manoeuvre the steering wheel to the required position. Hold the steering wheel in the required position and lock it by pulling the release lever up.

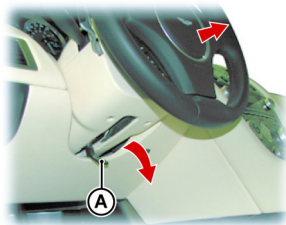

## Interior Mirrors

### Automatic Dimm Rear View Mirror

Adjust on its ball mounting until a satisfactory rear view is obtained. The rear view mirror will dim automatically if the glare from the headlamps of following vehicles becomes too bright. The mirror will return to normal view as unwanted glare reduces to an acceptable level. If the mirror is dimmed when reverse gear is selected the mirror will revert to normal view.

### Vanity Mirror

A vanity mirror is located in each sun visor.



## Door Mirrors

To adjust the door mirrors select the left or right mirror (B). Then move the joystick (A) up, down, left or right to adjust the selected mirror.

**📖** The vehicle key must at position 'I' or 'II' in the ignition control before the door mirrors can be adjusted.

**📖** An amber LED shows the selected mirror.

### Heated Mirrors

When the heated rear window is ON the heaters in the door mirrors will operate for 6.5 minutes.

### Power Fold Function

The power fold mirror function moves the door mirror assemblies until folded flat against the doors (folded).

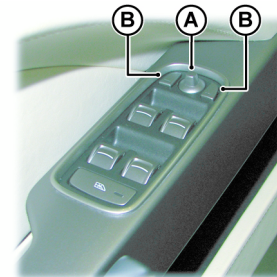



Insert the vehicle key to position 'I' or 'II' in the ignition control. Move the mirrors to the folded position by pressing down and releasing both the left and right mirror select switches (B) together. The mirrors will motor to the folded position. Repeat to motor the mirrors back to the driving position.

### Auto Fold function

When the vehicle is locked using the vehicle key the mirrors will automatically fold in flat against the doors. They return to the driving position once the vehicle is unlocked.

Press **MENU** (C) and navigate to <Car settings...> (Enter) <Mirror settings...> (Enter) <Auto mirror fold flat enabled>. Press **ENTER** to toggle between ON and OFF. Then press and hold **BACK** to accept and return to the main screen.



 If the mirrors have been folded using the power fold function then the mirrors will stay folded until placed in the driving position using the power fold function again.

 Door mirror vibration can occur if the mirrors have been moved manually (folded or unfolded), either intentionally or accidentally. To reset the linkage operate the power fold function once to fold or unfold the mirrors.

### Reverse Dip Function

This function gives a better view to the rear of the vehicle while reversing.

When reverse gear is selected:

**Automatic Mode** - When reverse gear is selected the door mirrors automatically move to the first preset dip position. If the mirror requires further lowering, press down and release the joystick again. If the mirror is lowered too far, press the mirror joystick up and release.

**Manual Mode** - Press down and release the mirror joystick (A). This will lower the door mirrors to preset position 1 dip. If the mirror requires further lowering, press down and release the joystick again. If the mirror is lowered too far, press the mirror joystick up and release.

In manual or automatic mode the mirrors return to driving view when reverse gear is de-selected or when either mirror button (B) is pressed.

### Reverse Dip Settings

Press **MENU** (C) and navigate to <Car settings...> (Enter) <Mirror settings...> (Enter) <Reverse mirror dip settings...>. Select <Auto (reverse gear selected)>, <Passenger only> or <Passenger and driver>.

Press **ENTER** to toggle between ON and OFF. Then press and hold **BACK** to accept and return to the main screen.

**<Auto>** - If set to ON: The door mirrors dip automatically when reverse gear is selected. If set to OFF: The door mirrors stay in manual mode.

**<Passenger only>** - Only the passenger door mirror dips.

**<Passenger and driver>** - Passenger and driver door mirrors dip.

## Restraints System

The restraints system gives protection to the driver and all passengers in a variety of impact conditions. The system consists of:

- Driver and passenger safety belts with pre-tensioners and load limiting systems
- Driver and front passenger dual-stage airbags
- Driver and passengers, door mounted, head airbags
- Driver and front passenger seat side airbags
- Front Passenger Airbag Deactivation (PAD) switch

All of these systems are controlled by a Restraints Control Module (RCM). In a collision the RCM will analyse information from various sensors, including crash and seat occupancy conditions. Based on this information the RCM will deploy the appropriate safety devices. During a crash, the RCM may or may not operate the safety belt pre-tensioners and none, one, or both stages of the dual-stage airbag supplemental restraints.

If the pre-tensioners or airbags do not operate in a collision it does not mean that something is wrong with the system. Rather, it means the system determined the accident conditions (crash severity, belt usage, etc.) were not appropriate to operate these safety devices.

Front airbags are designed to operate only in frontal and near-frontal collisions, not rollovers, side-impacts, or rear-impacts unless the collision causes sufficient longitudinal deceleration.

### Determining if the System is Operational

A warning symbol in the instrument cluster  shows the condition of the system. A difficulty with the system is shown by one or more of the following:

- The warning symbol will flash or stay ON
- The warning symbol does not come ON immediately after the ignition is set to ON

If either of these conditions occur, even intermittently, have the restraint system serviced at your Aston Martin Dealer immediately. Unless serviced, the system may not operate correctly in the event of a collision.

## Seat Belts

Aston Martin strongly recommend the use of seat belts.

**⚠ Warning: Seat belts should not be worn with straps twisted.**

**⚠ Warning: Each belt assembly must only be used by one passenger; it is dangerous to put a belt around a child being carried on the passengers lap. Do not put an adult seat belt around two children.**

**⚠ Warning: When installed, the seat belt webbing must not contact any sharp edges which could abrade or cut the webbing during normal use or in an accident. If necessary, the webbing must be protected.**

**⚠ Warning: Wearing your seat belt is crucial to your safety. Not wearing a seat belt increases chance of serious injury or death in the event of an accident.**

**⚠ Warning: Be sure that you and your passengers always fasten their seat belts and use them correctly even though airbags are provided.**

**⚠ Warning: Reclining the seat back decreases protection provided by the seat belt in the event of a crash. Adjust the seat back to an upright position.**

**⚠ Warning:** Seat belts are designed to bear upon the bony structure of the body, and should be worn low across the front of the pelvis, chest and shoulders; wearing the lap section of the belt across the abdominal area must be avoided.

**⚠ Warning:** Never place shoulder portion of belt under your arm or behind your back.

**⚠ Warning:** Always remove from your pockets rigid or breakable objects, i.e. spectacles or a mobile phone, which could be trapped under seat belts, possibly causing injury in the event of an accident.

**⚠ Warning:** Expectant mothers should seek medical advice on the most appropriate way to wear the seat belt.

**⚠ Warning:** Seat belts must be kept clean so that the retractor works correctly. Make sure that belt webbing is not twisted, looped, frayed or obstructed in any way. If in doubt about condition or operation of seat belt installation, have it checked by your Aston Martin Dealer.

**⚠ Warning:** No modifications or additions should be made by the user which will either prevent seat belt adjusting devices from operating, or prevent seat belt assembly from being adjusted to remove slack. Never install accessories on your seat belts.

**⚠ Warning:** Seat belts should be adjusted as firmly as possible, consistent with comfort, to provide the protection for which they have been designed. A slack belt will greatly reduce the protection afforded to the wearer.

**⚠ Warning:** It is essential to replace the entire seat belt assembly after it has been worn in a severe impact even if damage to the seat belt assembly is not obvious.

### Pre-tensioner and Load Limiting

All seat belts are equipped with pre-tensioner and load limiting systems.

In most moderate frontal or near frontal accidents, the front airbag and all pre-tensioner systems will deploy simultaneously.

The pre-tensioners take up slack in the seat belts as the airbags are expanding. The load limiting system releases belt webbing in a controlled manner to reduce belt force on the passenger's chest.

 In some moderate frontal or near frontal accidents, only the pre-tensioner system will deploy.

### Seat Belt Reminder

#### Front Passengers



A warning symbol in the instrument cluster will come ON and warning sound will be heard for six seconds (approximately) when the ignition is set to ON if the driver or front passenger<sup>1</sup> seat belt is not fastened<sup>2</sup>.

If the driver seat belt is not fastened after 60 seconds or if the vehicle reaches 25 kph a warning sound will be heard for 30 seconds, after which the warning sound will go ON and OFF and the warning symbol will continue to show until the seat belt is fastened<sup>2</sup>.

#### Rear Passengers

If a rear door has been opened and closed the message centre (right) will show the rear seatbelts status. The message will go OFF after 10 seconds once the vehicle has reach a speed of 7 km/h or press the **READ** button to clear the message immediately.

<sup>1</sup>. If a passenger is sitting in the front passenger seat.

<sup>2</sup>. Market area dependant

If a seat belt is unfastened during a journey the warning symbol and a message will show. The warning will stop once the seat belt is fastened or manually cleared by pressing the **READ** button.

#### To Disable or Enable the Rear Seat Belt Reminder

- Make sure that the ignition is set to OFF (ignition position '0') and that both rear seat belts are unfastened.
- Set the ignition to ON (ignition position 'II') and within 60 seconds fasten and unfasten a rear seat belt nine times. Finish with the belt unfastened.
- The message ENABLE/DISABLE REAR SEAT BELT REMINDER? will show in the message centre (right). Within five seconds fasten and unfasten the rear seat belt once more.
- The conformation message REAR SEAT BELT REMINDER ENABLED/DISABLED will show for 30 seconds.

The warning messages are always available, press the **READ** button to view stored messages.

#### Seat Belt Fastening

 When parked on an incline, the seat belt may lock as it is withdrawn. This is not a fault. If the mechanism locks, release the belt tension and then pull the belt very gently to avoid operation of the inertia lock.

Each seat has three point, inertia reel seat belts installed. Items 1, 2 and 3 show the three points of the seat belt. Item 3 is also the location of the belt buckle.

The inertia belt reels will automatically tension the belts to provide security with comfort. In the event of a collision or during severe braking, the belt reels will lock.

Pull out the seat belt, drawing the tongue over the shoulder and across the chest.



Push the tongue into the belt buckle latch until a positive click is heard.

Pull upwards on the diagonal belt to make sure that the latching is secure and to remove all slack from the belt.

Finally, double check that the lap belt is installed snugly, low down across the hips, and that there are no twists.

If it is necessary for a passenger to adjust their seat or seating position during a journey, the belt tension might be disturbed.

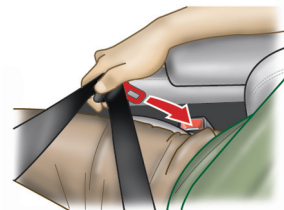

The passenger should therefore (as soon as it is safe to do so) gently pull down the shoulder run of the seat belt to create some slack and then immediately release it to re-tension the belt for the new seating position.



### Seat Belt Unfastening

Depress the button on the buckle. While holding the seat belt tongue allow the belt to slowly retract to its stored position.

### Child Seat Belt Fastening

**⚠ Warning: An infant or child that is not correctly restrained can be seriously injured or killed in a crash. Seat belts are designed for adults and larger children; infants and smaller children must be restrained in an approved child safety seat.**

Make sure that there is no slack in the webbing and that the restraint installs correctly across the child's rib cage and hips. These are the parts of the body most able to take the force of impact.

The lap strap should pass across the top of the child's thighs, bearing on the pelvis, not on the abdominal area.



## Airbags

### Supplemental Restraints System

The vehicle is equipped with driver and passenger airbags. The airbags and seat belt pre-tensioners are electrically controlled by the restraints system.

The front airbags (A) only deploy in a serious front collision. The side airbags, located in the front seats (B) and the door top panels (C) only deploy according to which side has been impacted in a serious side collision. The airbags mounted in the door top panels on each door are designed to protect the heads of the driver and passengers during certain side impacts.

The purpose of the airbags is to provide **additional** protection for the driver and passengers in the event of a serious impact (front or side impacts). The airbags are supplementary to the seat belts.

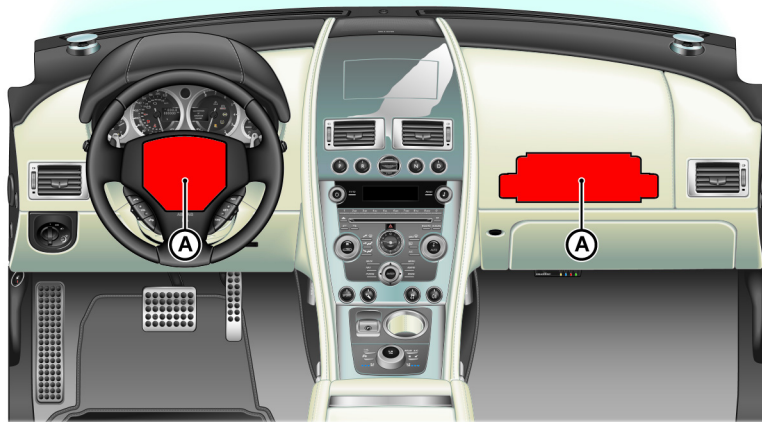

Important airbag safety labels are located on the sun visors and on the end of the instrument panel (passenger side). Make sure that the instructions on these labels are read and complied with before driving the vehicle.

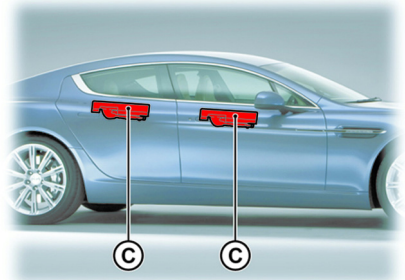

### Airbag Deployment

**⚠ Warning: The use of accessory seat covers may prevent the deployment of the side airbags and increase the risk of injury in an accident. Do not use accessory seat covers.**

**⚠ Warning: All passengers, including the driver, should always wear seat belts, whether or not an airbag is provided, to decrease the risk of injury or death in the event of a crash.**

**⚠ Warning: No objects whatsoever should be attached to the centre cover of the steering wheel or the front passenger fascia panel. Such objects could cause harm if the vehicle is in a collision severe enough to cause the airbags to deploy.**

Airbags inflate rapidly and with considerable force; there is therefore a risk of death or serious injury such as fractures, facial and eye injuries or internal injuries, particularly to passengers who are not correctly restrained by seat belts or are not sitting correctly when the airbags deploy. The risk of injury from a deploying airbag is greatest close to the trim panel covering the airbag.

The whole sequence of events from sensing the impact to full inflation of the airbag takes place in a fraction of a second. The noise and gas associated with the deployment of the airbags is not injurious to health.

Do not change, modify or tamper with the steering wheel, passenger side fascia or any other part of the airbag system. Such actions could disable the system or cause inadvertent airbag deployment.

The system will not deploy in the event of minor frontal or side impacts, such as contacts when parking.

The airbag system is not designed to protect against rear impacts. All work on the airbag system must only be carried out by an Aston Martin Dealer.

### Front Airbag Deployment

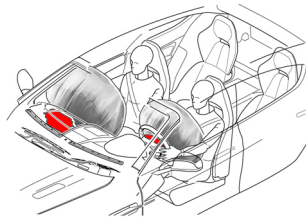

### Front Seat Airbag Deployment

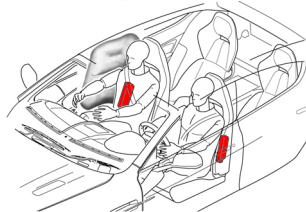

### Door Airbag Deployment

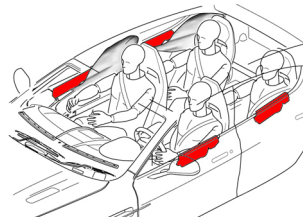

## Child Safety

Aston Martin strongly recommends:

- That all children are seated in the rear passenger seats.
- Not to install any child seat on the front passenger seat of this vehicle.
- Always use ISOFIX anchors where available.

A child, regardless of age, should always be restrained when travelling in a vehicle.

**⚠ Warning:** Accident statistics show that children are generally safer when correctly restrained in the rear seat than in the front seat. A suitable child restraint, correctly installed and used, provides the highest degree of protection for infants and small children in most accident situations.

**⚠ Warning:** Do not allow children to travel in a vehicle without restraint. An appropriate child seat or harness should always be used.

**⚠ Warning:** Each seat belt assembly must be used by only one passenger. It is dangerous to put a seat belt around a child being carried on the passenger's lap.



**⚠ Warning:** Make sure that an installed child seat does not rest against the door, that the child sits correctly in the seat and does not lean close to, or against, the door or window.

Your vehicle has the following devices for the installation of child restraints:

- Passenger Airbag Deactivation (PAD) switch
- ISOFIX anchors<sup>1</sup> (rear passenger seats only)
- Passenger seats Automatic Locking Retractor (ALR) seat belts
- Tether anchor points (rear passenger seats only)

### Child Seats and Front Passenger Airbag

**⚠ Warning:** Do not use a child restraint on a seat protected by a front airbag which is set to ON.

**⚠ Warning:** With the exception of installing a child seat on the front passenger seat, do not set the PAD switch to OFF, as the front passenger will not receive the added protection of the airbag. Serious injuries or even death could occur.

<sup>1</sup> Standard for installing child seats into cars and is intended to make the installation of child seats quick and simple

**⚠ Warning:** Never place a child in a child seat or on a booster cushion on the front passenger seat if the airbag is set to ON.

If a child seat is to be used in the front passenger seat, the front passenger airbag **must** be set to OFF. Make sure that the child seat manufacturer's installation instructions are followed correctly.

 The PAD switch does not set the front passenger side impact airbags or the seat belt pre-tensioners to OFF.

### Warning Labels

**⚠ Warning: Extreme Hazard:** Do not use a rearward facing child restraint on a seat protected by an active airbag in front of it.

The following warning labels<sup>2</sup> are located on the sun visors and on the end of the instrument panel (passenger side).

<sup>2</sup> Market area dependant.

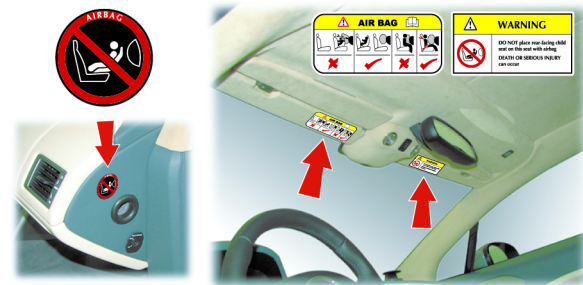

## Child Safety Locks

When the child locks are ON the rear doors can not be opened from the inside.

Press **MENU** (A) and select <Child lock enabled>. Press **ENTER** to toggle between child locks ON and OFF.

 In the event of a vehicle accident the rear doors will automatically unlock.



## Passenger Airbag Deactivation

**⚠ Warning:** Before installing a child seat on the front passenger seat, the front passenger airbag must be set to OFF.

**⚠ Warning:** Before driving always confirm that the PAD switch is in the appropriate position according to your requirements.

**⚠ Warning:** With the exception of installing a child seat on the front passenger seat, do not set the PAD switch to OFF, as the front passenger will not receive the added protection of the airbag. Serious injuries or even death could occur.

 The PAD switch does not set the passenger seat side impact airbags or the seat belt pre-tensioners to OFF.

The Passenger Airbag Deactivation (PAD) switch lets the airbag protecting the front passenger be set to OFF. When the PAD is set to OFF a child seat may be installed on the front passenger seat.

At ignition ON if the front passenger airbag is set to OFF 'PASS AIRBAG OFF' will show in the message centre (right).

The PAD switch is located on the passenger end of the instrument panel and is accessible when the front passenger door is open.



The PAD switch should be inspected by an Aston Martin Dealer if any of the following conditions occur:

- The PAD warning symbol does not come ON (for six seconds) when the ignition is set to ON and the passenger airbag is set to ON
- The PAD warning symbol does not stay ON when the ignition is set to ON and the passenger airbag set to OFF
- The PAD warning symbol stays ON when the ignition is set to ON and the passenger airbag is set to ON

## ISOFIX Anchors

### Set the Airbag to ON or OFF

Insert the emergency vehicle key (or similar, i.e. a coin) into the PAD switch and turn clockwise for the OFF position (airbag OFF) or counterclockwise for the ON position (airbag ON). Remove the key.

**Airbag ON** - When the ignition is set to ON make sure that the PASS AIRBAG OFF symbol comes ON for six seconds then goes OFF. Failure to follow the advice given above can endanger the life of the child.

**Airbag OFF** - Make sure that the PASS AIRBAG OFF symbol stays ON when the ignition is ON.



**PASS  
AIRBAG OFF**

**⚠ Warning: An unsecured child seat is dangerous. In a sudden stop or a collision it could move, causing serious injury or death to the child or other passengers. Make sure the child seat is correctly secured in place according to the manufacturer's instructions.**

**⚠ Warning: When installing the child seat, make sure that there are no seat belts or foreign objects near or around the ISOFIX anchors. If seat belts or a foreign object prevents the child seat from being securely attached to the ISOFIX anchors, the child seat could move in a sudden stop or collision causing serious injury or death to the child or other passengers.**

This vehicle is equipped with ISOFIX (International Standards Organisation FIX) anchors for the installation of child seats on the rear passenger seats. The anchors are located between the seat base and the seat back. The position of the anchors is shown by two tags at the base of the seat.

Remove the lower seat back panel (A). Place the panel in its storage area in boot (B).

 The seat back trim panels are left and right handed.

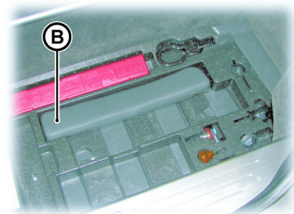
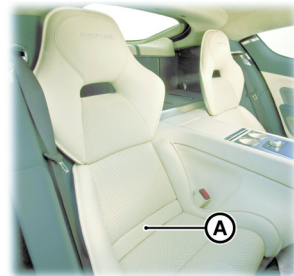

Secure the child seat using the ISOFIX anchors, following the child seat manufacturer's instructions.

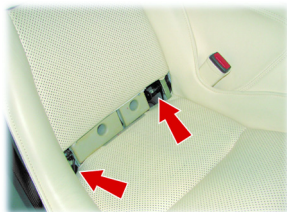

## Tether Anchors

**⚠ Warning: An infant or child that is not properly restrained can be seriously injured or killed in a crash. Seat belts are designed for adults and larger children; infants and smaller children must be restrained in an approved child safety seat.**

**⚠ Make sure that the child seat tether strap is always used when installing a child seat with ISOFIX anchors.**

**⚠ Warning: Child restraint anchorages are designed to withstand only those loads imposed by correctly fitted child restraints. Under no circumstances are they to be used for adult seatbelts, harnesses or for attaching other items or equipment to the vehicle.**

**⚠ Warning: Always follow the child seat manufacturer's instructions. Not following the child-seat manufacturer's instructions when installing the child seat is dangerous.**

**⚠ Warning: Make sure the child seat tether strap is free from obstructions above and below. Do not place any items on the tether strap between the child seat and the tether anchor point. Do not place tether strap over any items between the child seat and the tether anchor point.**

A tether is a strap that connects the top of a child seat to a tether anchor point on the vehicle to reduce excessive movement of the child seat in the event of a collision. The purpose of a tether strap is to provide additional protection for the child seat occupant in the event of a serious impact. The tether strap is supplementary to the seat belts. Your vehicle has a tether anchor point for each rear passenger seat.

The tether anchor point is located at the rear of the boot area (A). The boot space area must be configured as solution two (Refer to 'Boot Storage', page 3.23)

## Automatic Locking Retractors

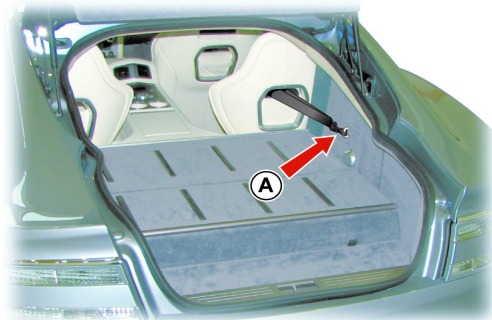

Route the tether strap through the seat back as shown. Engage the tether clip to the anchor point as shown and make sure that the locking spring has fully closed to prevent accidental disengagement. Always make sure that the tether strap length is adjusted to remove any slack.

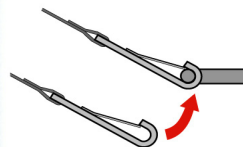
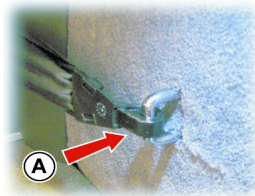

**⚠ Warning:** Always follow the child seat manufacturer's instructions. Not following the child-seat manufacturer's instructions when installing the child seat is dangerous.

Aston Martin does not recommend any specific child seat for this vehicle **which require the use of the vehicle seat belt for installation.**

The Automatic Locking Retractor (ALR) system is designed to securely hold child seats. The ALR system temporarily locks the seat belt that is securing a child seat.

### ALR Operation

Gently pull out the seat belt until fully extended. The ALR system will only engage at the maximum extension point of the seat belt.

Thread the belt tongue through the child seat as instructed by the child seat manufacturer. Engage the tongue into the belt buckle.

Adjust the tongue position on the belt, if necessary, to make sure that the lower belt run is tight and then allow the upper run of the seat belt to fully retract until the child seat is securely held. The ALR system will be heard 'clicking' as the seat belt retracts.

When fully retracted, pull down on the upper run of the belt to check that the ALR lock has engaged.

 When parked on an incline, the seat belt may lock as it is withdrawn. This is not a fault. If the mechanism locks, release the seat belt tension and then pull the seat belt very gently to avoid operation of the inertia lock.

The ALR system will disengage when the seat belt is fully retracted. The seat belt may then be worn when required as a normal seat belt. Once the ALR is disengaged, the seat belt must be fully extended to re-engage the system on the next occasion that a child seat is installed.

## Child Seats

**⚠ Warning: Always follow the child seat manufacturer's instructions. Not following the child seat manufacturer's instructions when installing the child seat is dangerous.**

**⚠ Warning: Do not seat a child aged 12 or younger, or weighing 36 kg or less in the car without an appropriate child seat or booster cushion.**

Aston Martin recommends the installation of Aston Martin child seats, which use ISOFIX. Contact your Aston Martin Dealer for more information on Aston Martin child seats.

### Use of Child Seats

When installing child seats on the rear seat(s) make sure that there is sufficient room between the front seat back and the child seat, if required move the front seat forward. When installing the BabySafe Plus and ISOFIX base make sure that there is at least a 5 cm gap between the child restraint and the front seat (A).

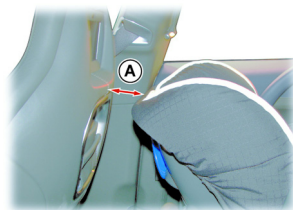

Look for the following when selecting a child seat:

- It should have a label certifying that it meets the applicable Safety Standards
- Carefully read the instructions supplied with the child seat. Make sure you understand them and can install and use the device correctly and safely in the vehicle
- Make sure that the child seat is appropriate for the child's weight and development. The label required by the standard or regulations, or instructions for infant seats, usually provide this information

An infant or child that is not correctly restrained can be seriously injured or killed in a crash. Seat belts are designed for adults and larger children; infants and smaller children must be restrained in an approved child seat.

Children could be endangered in a crash if their child seat is not correctly secured in the vehicle.

Never hold a baby or child on your lap while riding in the vehicle.

Consult with local manufacturers of forward facing restraint and booster cushions. These manufacturers can supply you with advice on the safety of their particular child restraints.

Check the seat manufacturers instructions for correct use and installation – use the correct size seat and correctly secure the seat in the vehicle in accordance with the manufacturers instructions. Be sure to read and follow the ‘Installation and Use Instructions’ provided with the child seat.

### Child Seats - ISOFIX Installation

Always follow the child seat manufacturer’s instructions. Not following the child-seat manufacturer’s instructions when installing the child seat is dangerous.

Mass Group <sup>1</sup>	Size Class	Fixture	ISOFIX Positions	
			Front Passenger	Rear Outboard
Carry Cot	F	ISO/L1	X	X
	G	ISO/L2	X	X
‘0’ Up to 10kg (0-9 months)	E	ISO/R1	X	X
‘0+’ Up to 13kg (0-18 months)	E	ISO/R1	X	IL <sub>2</sub>
	D	ISO/R2	X	X
	C	ISO/R3	X	X
‘1’ 9 to 18kg (9 months to 4 years)	D	ISO/R2	X	X
	C	ISO/R3	X	X
	B	ISO/F2	X	IUF
	B1	ISO/F2X	X	<sub>3</sub> IUF
	A	ISO/F3	X	X

<sup>1</sup>. As shown on the child safety seat packaging

<sup>2</sup>. Aston Martin branded Britax Baby - Safe Plus II

<sup>3</sup>. Aston Martin branded Britax Baby - Safefix Plus

Mass Group <sub>1</sub>	Size Class	Fixture	ISOFIX Positions
-------------------------	------------	---------	------------------

'II'	15 to 25kg (4 to 12 years)		X X
------	----------------------------	--	-----

'III'	(22 to 36 kg (4 to 12 years))		X X
-------	-------------------------------	--	-----

**Key**

**IUF** - Suitable for 'ISOFIX' forward child restraints systems of universal category approved for use in the mass group.

**IL** - Suitable for particular ISOFIX Child Restraint Systems (CRS). These ISOFIX CRS are those of the 'specific vehicle', 'restricted', or 'semi-universal' categories.

**X** - ISOFIX position not suitable for ISOFIX child restraint systems in this mass group or this size class.

Supplied under EC Directive 77/541.

<sup>1</sup>. As shown on the child safety seat packaging

**Child Seats - Seat Belt Installation**

Consult with local manufacturers of forward facing restraint and booster cushions. These manufacturers can supply you with advice on the safety of their particular child restraints and also advice on installation instructions.

Mass Group <sub>1</sub>	Seating Position
-------------------------	------------------

'0'	Up to 10kg (0-9 months)	Front Passenger	Rear Outboard
-----	-------------------------	-----------------	---------------

'0+'	Up to 13kg (0-18 months)	U <sub>2</sub>	U
------	--------------------------	----------------	---

'I'	9 to 18kg (9 months to 4 years)	U <sub>2</sub>	U
-----	---------------------------------	----------------	---

'II'	15 to 25kg (4 to 12 years)	U <sub>2</sub>	L <sub>3</sub>
------	----------------------------	----------------	----------------

'III'	(22 to 36 kg (4 to 12 years))	U <sub>2</sub>	U
-------	-------------------------------	----------------	---

'III'	(22 to 36 kg (4 to 12 years))	U <sub>2</sub>	U
-------	-------------------------------	----------------	---

**Key**

**L** - Suitable for particular child restraint systems. These restraints may be of the 'specific vehicle', 'restricted' or 'semi-universal' categories.

**U** - Suitable for 'universal' category restraints approved for this mass group.

**X** - Seat position not suitable for children in the mass group.

\* - Unsuitable for use with many child restraints due to limited space.

Supplied under EC Directive 77/541.

<sup>1</sup>. As shown on the child safety seat packaging

<sup>2</sup>. Move the passenger seat to its rearmost and highest position.

<sup>3</sup>. Mass Group II - Aston Martin branded Britax Kidfix ISOFIT (Refer to 'Britax Kidfix ISOFIT Child Seat', page 3.23)



## Britax Kidfix ISOFIT Child Seat

Aston Martin branded

**⚠ Warning:** *The lap or diagonal seat belt is only to be used to restrain the child in the child seat. Do not use the lap or diagonal seat belt to install the child seat. Always use the Britax Kidfix ISOFIT child seat ISOFIT latches.*

### Rear Seat Install

Install the Britax Kidfix ISOFIT child seat to the rear seat ISOFIX anchors as per the manufactures instructions and make sure that there is sufficient room between the front seat back and the child seat, if required move the front seat forward. Adjust the height of the child seat headrest as required according to the manufactures instructions. **Make sure that the headrest does not come into contact with the rear door top trim panel.**

## Boot Storage

The boot area has three different configuration options to let various small or large items be placed in the boot.

### Configuration One

Lift the boot divide panel up. With the boot divide panel raised and the parcel shelf in place items placed in the boot are hidden from view.



### Configuration Two

Lay the boot divide panel down.

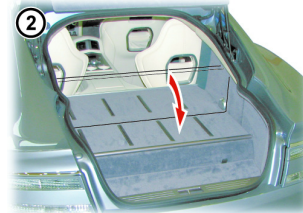

### Configuration Three

Lower one or both of the rear seat backs.



### Parcel Shelf

The parcel shelf has two lugs which locate into the boot lid and two magnets which hold the shelf in place.

To remove the parcel shelf over come the magnets and pull the base away from the glass by two or three centimetres (A). Then gently lower the shelf away from the boot lid to release the two lugs (B). To install the shelf insert the two lugs into the boot lid and bring the top of the shelf up to the boot lid and let the magnets hold the shelf in place.

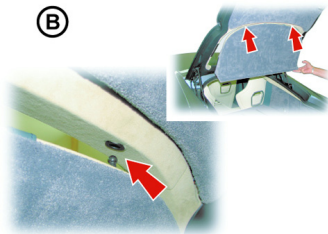

When not in use the parcel shelf locates in the boot floor space, with the two leather straps facing down and the two lugs facing the boot rear, as shown (C).

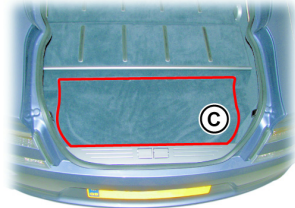

## Cabin Storage

### Glove Box

Press the glove box button (A) to open. Push up to close.

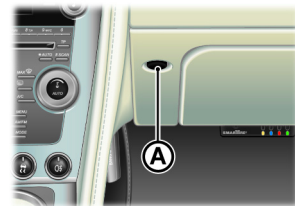

## Cup Holders

**⚠ Warning: Only use the cup holder when safe to do so.**

**⚠ Warning: Do not place hot drinks in the cup holder while the vehicle is in motion. There is a risk of scalding.**

**⚠ Warning: Use soft cups only. Hard cups or objects can cause personal injury in a collision.**

Cup holders are located the front and rear centre consoles.



## Front and Rear Cubby Boxes

The front cubby box has an iPod, USB ports, an auxiliary socket and an accessory socket.



The rear cubby box has the auxiliary inputs for the rear entertainment system and an accessory socket.



## Door Pockets

All four doors have pockets (with removable mats).

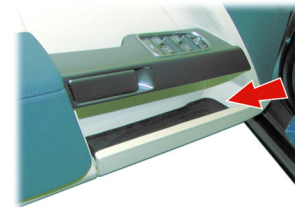

## Front Seat Pockets

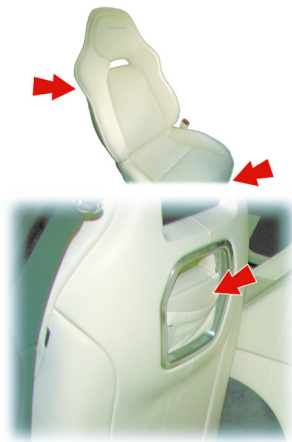

## Media Devices

A dedicated Apple iPod<sup>1</sup> player port is provided in the front cubby box, along with a USB port for the connection of USB devices and an 3.5 mm jack socket for other media devices.

After connecting the iPod or other device it can then be operated via the vehicle audio system (Refer to 'iPod and USB Functions', page 7.13).

Music devices connected using the 3.5 mm jack socket will not be operated by the vehicle audio system or have their batteries charged (Refer to 'Auxiliary Functions', page 7.15).

 iPod batteries and USB devices which require a power source are charged while connected. A music device, connected by the 3.5 mm jack socket, can be powered using the accessory socket mounted in the armrest cubby box.

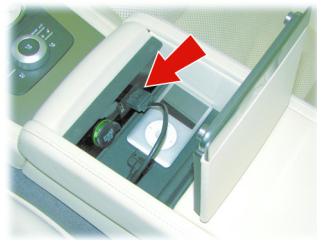

The rear cubby box has six phono jack sockets for the installation of game consoles, a video camera, personal audio or video players, or other input devices to be used with the rear seat entertainment system (Refer to 'Rear Seat Entertainment', page 8.1).

<sup>1</sup> iPod is a trademark of Apple Inc.

## Accessory Socket

**⚠ Warning: Damage to electrical circuits will result if more than 10 amps is drawn from the accessory socket. Only connect accessories which are designed for use in a motor vehicle.**

**⚠ Warning: Prolonged use of accessory socket when vehicle is stationary may seriously discharge battery.**

Accessory sockets are mounted in the front and rear armrest cubby boxes, the boot right side wall (A) and the boot left side wall behind the trim panel (B) and may be used to power any 12 volt vehicle accessory requiring a current of less than 10 amps. The boot mounted accessory sockets are a constant live.

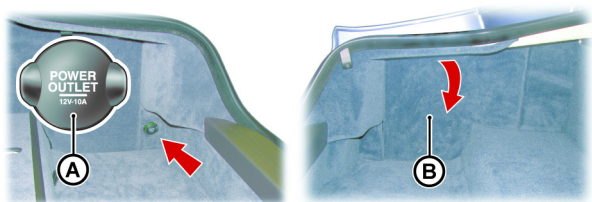

Read the manufacturer's instructions and make sure that you do not connect any device which would exceed current rating of the accessory socket.

**⚠ Foreign items can get into the socket and cause damage - always place the cover on the accessory socket when not in use.**

## Ashtray and Cigar Lighter

(Option)

**⚠ Warning: The cigar lighter is heated to 'red heat' when in use. Take care to avoid burns. Do not allow children to play with the cigar lighter.**

The cigar lighter can be used in any in cabin accessory socket when the vehicle key is in ignition position 'I' or 'II'.

Push down until it clicks. The lighter will pop up when ready for use.

**⚠ Foreign items can get into the socket and cause damage - always place the lighter back into the accessory socket when not in use.**

The ashtray installs into any of the cup holders.

## Electric Windows

**⚠ Warning: Misuse of the window switches, especially by children, can result in injury due to entrapment in the window closure. Drivers must advise all passengers of the possible danger and make sure that all obstructions are clear before raising the window.**

 The windows can be operated up to one minute after the vehicle key is removed from the ignition control.

Each vehicle door has its own window switch. The drivers door window switch can operate all windows and, for safety, can lock both rear door window switches.

To raise and lower the windows the vehicle key must be at ignition position 'I' or 'II'.

Lightly press and hold a window switch ((A (drivers door) or B (other doors)) to lower the window in one movement. Lightly press and release the window switch to lower the window in stages.

Firmly press and release to lower the window with one touch.

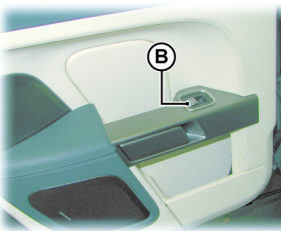
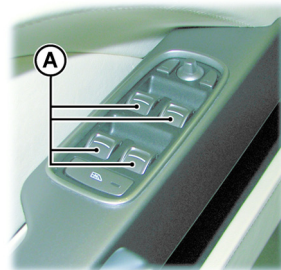

Lightly pull back and hold to raise the window in one movement. Lightly pull back and release the window switch to raise the window in stages. Firmly pull back and release to raise the window in one movement (only when the door is closed)<sup>1</sup>.

If a rear door window is lowered the front door window (on the same side) will also lower a few millimetres (still maintaining a water tight seal). As the rear window is raised the front window will raise.

If power to the electric windows has been interrupted for any reason, they will fail to operate correctly until reset (Refer to 'Door Window Reset', page 11.30).

### Operation with Vehicle Key

When locking or unlocking the vehicle with the vehicle key, press to lock or unlock and hold until the windows start to move, then release. The door windows will fully raised (when locking) or lower (when unlocking).

<sup>1</sup>. One movement operation will not work if the anti-trap is faulty

## Window Anti-Trap

The anti-trap sensor detects an obstruction between the window glass and the door seal during window closing. The window will continue to close until the obstruction is sensed by the door seal sensor, closing then stops and the window backs off. This is a safety feature designed to prevent inadvertent closing of a window on vulnerable parts of the body or other obstructions. Remove any obstruction and then close the window.

If, for any reason it is required to override the anti-trap mechanism, lift and hold the relevant window switch until the window has closed.

## Rear Door Window Lock

The rear door windows can be locked so that rear passengers can not operate them. Open or close the windows as required then press and release the rear door window lock button (C) to lock. Press and release again to unlock.

## Door Sealing

**⚠ Warning: Make sure that all passengers are clear when the window mechanism is operating.**

To minimise wind noise and to make sure that the window seal is watertight a door sealing system is used to provide a tight fit of the door glass to the seals around the top of the door opening.

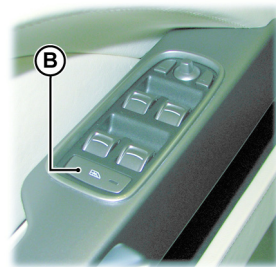

When a door is opened, the windows in both doors, on the same side, automatically lower a small distance to clear the door seal. As the door is closed, both door windows automatically, after a pause, lift against the body frame rubber seals (rear door lifts first). As the vehicle speed reaches 7 km/h the front door windows will lift a small amount again to make sure of a good water tight seal.

## Reading Lamps

Reading lamps are located in the front (A) and rear (B) environments. The lamps are set to ON and OFF by the individual switches mounted on the front and rear centre console.

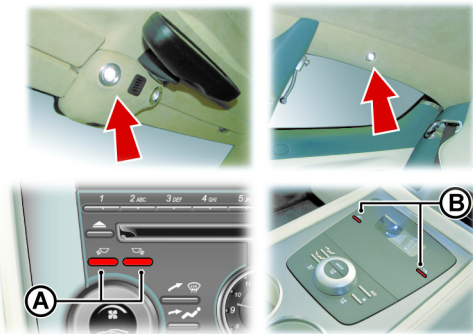

Unless set to OFF or ON they will continue to operate up to six minutes after the ignition is set to OFF.

## Coat Hooks

Coat hooks are located in the grab handles, one above each rear passenger door (A).

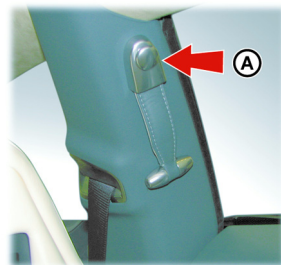

ASTON MARTIN





ASTON MARTIN



ASTON MARTIN



ASTON MARTIN



ASTON MARTIN



ASTON MARTIN



ASTON MARTIN



# Controls

Controls Overview .....	4.2
Instrument Cluster .....	4.3
Information and Warning Symbols .....	4.5
Centre Stack .....	4.8
Ignition Control .....	4.10
Stalk Controls .....	4.11
Master Lamp Switch .....	4.12
Vehicle Horn .....	4.13
Trip Computer .....	4.14
Cruise Control .....	4.15
Ambient Temperature .....	4.16
Tyre Pressure Monitoring .....	4.17

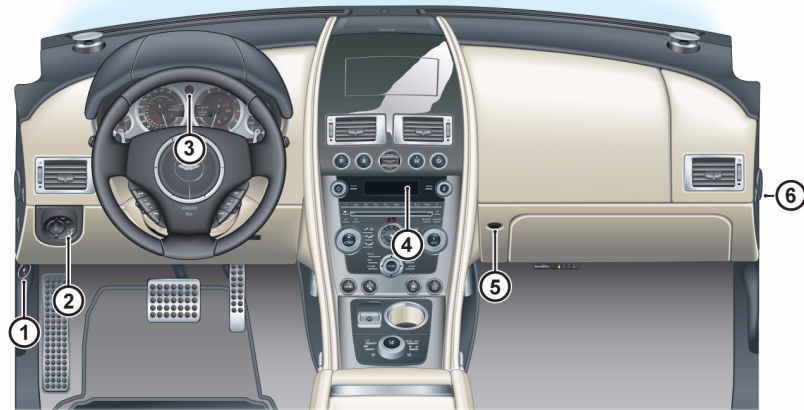

**[1] FUEL FLAP RELEASE** - Press to open the fuel flap. Close the fuel flap by pressing down on the flap until the lock engages.



**Filler Flap Emergency Release:**(Refer to 'Fuel Flap Release', page 2.6)

**[2] MASTER LAMP SWITCH - [A]** - All external lamps OFF.

**[B]** - Side lamps, side marker lamps, rear lamps and registration plate lamps ON.

**[C]** - Headlamps ON, in addition to the side, side marker, rear and registration plate lamps.

**[D]** - The level of instrument brightness can be reduced or increased by using the rotary control. Push the rotary control in and release to enable the control. Push in and release to lock the control.

**[3] INSTRUMENT CLUSTER** - (Refer to 'Instrument Cluster', page 4.3)

**[4] CENTRE STACK** - (Refer to 'Centre Stack', page 4.8)

**[5] GLOVE BOX RELEASE** - Press to open the Glove box. Push the Glove box lid up to close.

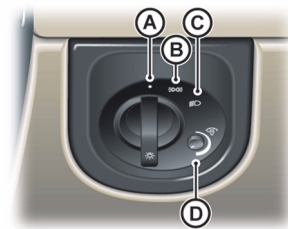

## Instrument Cluster

**[6] AIRBAG DEACTIVATION** - The passenger airbag **must** be set to OFF if installing a child seat on the front passenger seat (Refer to 'Passenger Airbag Deactivation', page 3.16).



**[1] FUEL GAUGE** - Shows how much fuel is in the fuel tank. Refuel as soon as possible when the low fuel symbol comes ON.

**[2] SPEEDOMETER** - Shows vehicle road speed.

**[3] MESSAGE CENTRE (LEFT)** - Shows the following:

**[A] TRIP METER** - The Trip meter shows distances travelled since last reset of trip meters T1 and T2 (A). Toggle between T1 and T2 by pressing **T1/T2** (F) for less than three seconds. Press **T1/T2** for more than three seconds to reset the trip meter on show.

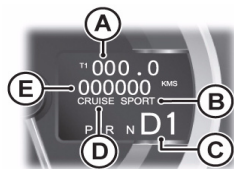

**[B] SPORT MODE STATUS** - Shows 'SPORT' (B) when sport mode is ON.

**[C] GEAR RANGE** - Shows the transmission position and current gear selection (C). Possible transmission positions and gear selection are in bold.



**[D] CRUISE STATUS** - Shows CRUISE (D) when cruise control is ON (Refer to 'Cruise Control', page 4.15).

**[E] ODOMETER** - Shows the total distance covered by the vehicle (E).

**[4] GEAR POSITION INDICATOR** - Shows the current transmission position when in **Auto Drive** mode and the current gear selection when in **Touchtronic** mode (Refer to 'Automatic Transmission', page 5.3).



**[5] MESSAGE CENTRE (RIGHT)** - Shows the following:

- **Driver Information and Warnings**

Messages show if an unsatisfactory condition is detected. Message priority is shown by a red or amber triangle above the message display.

**Red:** Potential personal danger or danger of damage to the vehicle.

**Amber:** Advisory, shows possible degraded vehicle performance.

Warning messages will show when the ignition is ON and will cycle automatically.

View and acknowledge messages at any time by pressing the **READ** button (G).

- **Service Intervals**

TIME FOR REGULAR SERVICE will be shown when a regular vehicle service is due. This message will show at ignition ON (for two minutes) until the regular service has taken place.

- Trip computer  
The message centre (right) defaults to the trip computer when there are no messages to show.

**[6] TACHOMETER** - Shows the engine speed in revolutions per minute x 1000.

**[7] ENGINE COOLANT**

**TEMPERATURE GAUGE** - Shows the temperature of the engine coolant.



## Information and Warning Symbols



[1]  **LOW FUEL WARNING** - Comes ON when only approximately 13 ltr of fuel is available. At 13 ltr and 7 ltr an audible 'beep' will sound and the 'estimated distance' message will show (for 20 seconds) in the message centre (right). The arrow head shows which side of the vehicle the fuel flap is.



[2] **LEFT TURN INDICATORS** - Flashes with the indicator or hazard warning lamps (Ignition ON).



[3] **HEADLAMPS** - Shows that the main beam of the headlamps is in use.



[4] **SIDE LAMPS** - Shows that the side lamps, dip or main beams are ON.



[5] **PATS** - If this symbol flashes continuously at ignition ON the vehicle will stay immobilised. If the symbol is ON continuously at ignition ON the vehicle will start but PATS has gone into 'Fail Safe' mode (Refer to 'Passive Anti-Theft System', page 2.11).

**Vehicles with Aston Martin Tracking Installed:** If the PATS symbol continues to stay ON after the vehicle has started the driver recognition tag may not be in range of the tracking system.

 **Warning: Stop immediately if the check engine symbol flashes, do not drive the vehicle. Contact your Aston Martin Dealer.**



[6] **CHECK ENGINE** - Steady amber shows a fault in the engine management system. Continue driving only if there are no audible, visible or physical signs of degraded engine performance. Consult your Aston Martin Dealer as soon as possible.

Flashing amber shows a major fault in the engine management system. Stop immediately. Contact your Aston Martin Dealer.



[7] **IGNITION WARNING** - Comes ON when the ignition is set to ON and goes OFF when the engine is started and battery charging commences. Comes ON if battery charging fails whilst driving.



[8] **OIL PRESSURE WARNING** - Comes ON when the engine oil pressure falls below minimum. Do not continue driving if this symbol stays ON. Contact your Aston Martin Dealer immediately.

 **Warning: Do not drive the vehicle if the SRS warning symbol stays ON. Have the system checked by an Aston Martin Dealer.**



[9] **SUPPLEMENTARY RESTRAINT SYSTEM** - At vehicle key position 'I' and 'II' or on vehicle start up, this symbol comes ON for a few seconds as a readiness sign.

If it does not come ON, or if it does not go OFF after a few seconds, or if it comes ON whilst driving, the airbag self diagnostic system has detected a fault.

 **Warning: Do not drive the vehicle if the seat belt warning symbol stays ON. Have the system checked by an Aston Martin Dealer.**



[10] **SEAT BELT WARNING** - This warning symbol will come ON and a chime will sound for six seconds if the driver's seat belt is not fastened when the ignition is set to ON. The chime will continue to operate at different vehicle speeds until the seat belt is fastened<sup>1</sup>.

<sup>1</sup>. Market dependant.

[11]  **WARNING TRIANGLE** - Shows Red or Amber depending on the warning or information message priority.



**Warning:** If the brake warning symbol stays ON, after fully releasing the park brake do not drive the vehicle. Have the system checked by an Aston Martin Dealer.

[12]  **BRAKE WARNING** - At ignition ON this symbol comes ON when the park brake is applied and goes OFF when the park brake is fully released. If the symbol stays ON, after fully releasing the park brake, it shows that either the brake fluid level is low or that the brake pads require regular maintenance.

**Warning:** If the ABS warning symbol stays ON, do not drive the vehicle. Have the system checked by an Aston Martin Dealer.

[13]  **ABS WARNING** - If this symbol stays ON or comes ON while driving there is a fault in the ABS control circuits. Continue driving only if there are no audible, visible or physical signs of degraded brake performance. Consult your Aston Martin Dealer as soon as possible if this symbol stays ON.

[14]  **TYRE PRESSURE** - If this symbol stays ON or comes ON while driving, a tyre or tyres air pressure is below specification.

[15]  **DYNAMIC STABILITY CONTROL** - When DSC is ON this symbol will flash when the DSC system is operating. When the Dynamic Stability Control (DSC) system is in sport mode or OFF this symbol will show as a warning that DSC is partly ON or OFF. If, while DSC is ON, the DSC symbol stays ON or it comes ON whilst driving, the DSC system has detected a fault. A DSC fault message will show in the message centre (right). Consult your Aston Martin Dealer as soon as possible.



[16]  **ELECTRONIC PARK BRAKE** - This symbol shows if there is a fault with the electronic park brake. A warning message will also show in the message centre (right) along with the amber warning triangle. Consult your Aston Martin Dealer as soon as possible.

[17]  **REAR FOG LAMP** - Shows if the rear fog lamps are ON.

[18]  **RIGHT TURN INDICATORS** - Flashes with the indicator or hazard warning lamps (Ignition ON).

[19]  **HIGH COOLANT TEMPERATURE** - Shows when the engine coolant temperature exceeds 120°C.

### Engine Oil Level Sensing

 **The electronic engine oil level sensing system does not replace the need for the owner to regularly check their engine oil using the dipstick. Check the engine oil level every fourth fuel tank fill or weekly - which ever is the soonest.**

This vehicle has an electronic engine oil level sensing (OLS) system which records the engine oil level each time the fuel tank is filled with 25 litres or more of fuel.

 **Running the engine with engine oil below the minimum mark on the dipstick can cause serious engine damage.**

 *The system may not record an oil level if the engine oil temperature is low or if the time to refuel is not sufficient for a consistent oil level to be recorded.*

For the correct engine oil refer to Fluids and Capacities (Refer to 'Fluids and Capacities', page 12.9).

If the engine oil level is low the message OIL LEVEL LOW ADD 1L will show in the message centre (right) along with an amber warning triangle and a chime sound. The engine oil level is low and should be topped up with one litre of engine oil as soon as possible.

The engine oil level should then be checked and topped up as soon as possible (Refer to 'Fluid Levels', page 11.7).

Press the **READ** button to acknowledge the message. The message will clear when the ignition is set to OFF and then ON.

### Low Outside Temperature

 **Warning: Even if the ICE WARNING message does not show, there is no guarantee that at low temperatures the road is free from ice.**

At temperatures below 4°C the message ICE WARNING is shown in the message centre (right), this shows to the driver that frost or ice is likely to form on road surfaces.

The amber warning triangle  will also come ON.

The message and warning triangle will continue to show until the outside temperature rises to a safer level.

### Warning Symbols

As the ignition is set to ON, the electronic control units complete a self check. During these checks the following symbols will come ON for five seconds and SYSTEM CHECK will show on the message centre (right).

Under normal circumstances most warning symbols will go OFF at the end of the individual system check if system checks are satisfactory.



## Centre Stack

### [1] SATELLITE NAVIGATION

**SCREEN<sub>1</sub>** - Opens when the Satellite Navigation system is set to ON (Refer to 'Satellite Navigation', page 10.1).

**[2] IGNITION CONTROL** - Insert the vehicle key for ignition positions '0'. 'I', 'II' and engine start (Refer to 'Ignition Control', page 4.10).

### [3] TRANSMISSION CONTROLS

Park, reverse, neutral and drive controls (Refer to 'Automatic Transmission', page 5.3).

**[4] AIRBAG STATUS** - Shows the passenger airbag status (Refer to 'Passenger Airbag Deactivation', page 3.16).

**[5] DISPLAY** - Shows options, menus and information.



**[6] HAZARD WARNING LAMP** - Press to set the hazard warning lamps to ON or OFF.

**[7] CLOCK** - To set the time press **MENU**. Go to <Car settings...> (Enter) <Clock>.

**[8] READ** - Press to view and acknowledge messages.

**[9] AUDIO CONTROLS** - (Refer to 'Audio', page 7.1)

**[10] CLIMATE CONTROLS** - (Refer to 'Climate Control', page 6.1).

**[11] MODE AND MENU NAVIGATION** - Select functions and move back in the menus. Use the joystick to navigate for menus, music tracks, radio stations. Press to accept.

**[12] READING LAMPS** - Driver and passenger reading lamps.

**[13] T1/T2** - Select between two trip meters (Refer to 'Instrument Cluster', page 4.3).

**[14] REAR FOG LAMPS** - Used in with the dipped beam when fog or mist is causing restricted visibility. They **must** be set to OFF when visibility clears to reduce glare to the drivers of following vehicles.

**[15] DYNAMIC STABILITY CONTROL** - The Dynamic Stability Control (DSC) system defaults to ON at each ignition ON. Press and hold for approximately four seconds for sport mode. Press and hold again for approximately four seconds to set DSC to OFF. Press and release to set DSC ON again (Refer to 'Dynamic Stability Control', page 5.9).

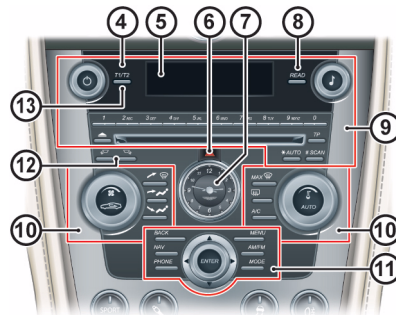

<sup>1</sup>. Not available in all markets.

**[16] REAR A/C** - Press and release to set the rear climate from the front controls (Refer to 'Rear Environment', page 6.7).

**[17] MASTER VEHICLE LOCK** - Press to lock all doors and disable the boot lock switch. Press again to unlock (Refer to 'Master Locks', page 2.5).

**[18] SEAT TEMPERATURE CONTROL** - Press and release to select the left or right seat. Turn the dial to set seat temperature (Refer to 'Temperature Controlled Seats', page 3.4).

**[19] PARKING ASSIST** - Defaults to OFF at each ignition ON. Park assist comes ON when reverse gear is selected. Press and release to set parking assist to OFF (Refer to 'Front and Rear Parking Assist', page 5.13) or (Refer to 'Rear Only Parking Assist', page 5.15).

**[20] BOOT OPEN** - Press to open the boot lid.

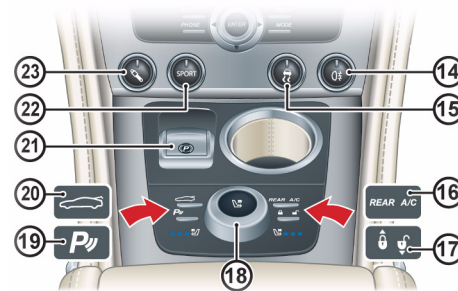

**[21] PARK BRAKE** - Pull the park brake switch up and release to apply the park brake. To release the park brake the ignition control must be at position 'II', then apply pressure to the foot brake and press down on the park brake switch and release.

**[22] SPORT MODE** - Press the sport button once to enter transmission sport mode and press again to exit (Refer to 'Sport Mode', page 5.5).

**[23] ADAPTIVE DAMPING** - The Adaptive Damping System (ADS) defaults to normal mode at each ignition ON. Press and release for ADS sport mode (button LED ON) (Refer to 'Adaptive Damping', page 5.11).

## Ignition Control

To access vehicle functions and to start the engine the vehicle key must be inserted into the ignition control.



**⚠ Warning:** Only use the vehicle key in the ignition control. Do not place any objects, including fingers, into the ignition control other than the vehicle key. Objects other than the vehicle key may cause the ignition control to fail.

**⚠** The vehicle key must only be inserted into the ignition control with the two indents first, as shown. Attempting to insert the larger end first the key may damage the ignition control.

### Position '0' (Ignition OFF)

Auxiliaries OFF (audio, rear seat entertainment system, satellite navigation, hands-free phone not available), steering lock ON. Seats can be adjusted.

Gently insert the vehicle key, indents first, into the ignition control. Press in until the key clicks into place (approximately 20 mm (A)) then release. The key is docked at this point.

Remove by pulling the vehicle key from the ignition control.

### Position 'I' (Ignition OFF and Accessories ON)

Auxiliaries ON (audio, rear seat entertainment, satellite navigation, hands-free phone available), steering lock ON.

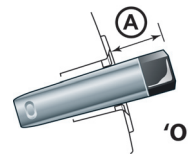

- If already in position '0' gently press the key until the infotainment centre and the instrument cluster lamps come ON (a further 10 mm (B)) and release for position 'I'.
- Or insert the key into the ignition control and move straight to position 'I'. Press in until the infotainment centre and the instrument cluster lamps come ON.

Remove by pulling the vehicle key from the ignition control.

### Position 'II' (Ignition ON)

Ignition and all other electrical systems ON, steering lock OFF.

**⚠** Do not depress the brake pedal unless intending to start the engine.

 Insert the key to position 'II' by using the flat of a finger, as shown.

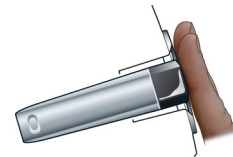
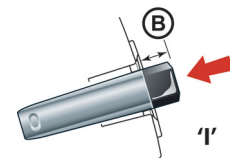

- If the key is already in position '0' or '1' gently press the key until it is flush with the ignition control bezel and release.
- Or insert the key into the ignition control and move straight to position 'II'. Gently press the key until it is flush with the ignition control bezel and release.

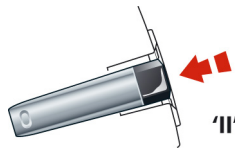

The Instrument cluster lamps will come ON, the vehicle systems will wake up and the steering lock will release.

Remove the vehicle key from position 'II' by pressing the key fully in **twice**, without depressing the brake pedal, and release. The key will gently return to position 'I'. Pull the key from the ignition control. Once in position 'I' after 10 seconds the steering lock will engage.

 If the vehicle key is pressed **fully** into the ignition control and released for position 'II', the key must be returned to position 'I' to start the engine.

### Starting the Engine

(Refer to 'Starting the Engine', page 5.2).

### Preventing Unnecessary Battery Drain

If the vehicle key is left in the ignition control (position '0'), some vehicle circuits will stay ON and unnecessary current will be drawn from the battery.

Always remove the vehicle key from the ignition control whenever the ignition is set to OFF.

## Stalk Controls

### Left Side Stalk

**Turn Signals** - Press up for a right turn, press down for a left turn. Returns to the centre position on completion of a manoeuvre. Hold against spring pressure to show a lane change.

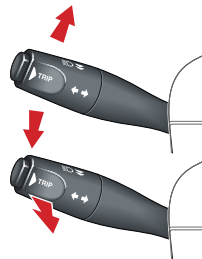

**Main and Dipped Beam** - Pull forwards and latch for main beam. Pull forwards again and latch to return to dipped beam. Pull forwards and release without latching, at any time while the vehicle key is in the ignition control, to flash main beam ON and OFF.

Pull forwards and release without latching, when the vehicle key is removed, to start Homesafe (Refer to 'Homesafe', page 2.9).

**Trip Computer** - Repeated pressing of the trip function button (A) moves through the trip computer displays. (Refer to 'Trip Computer', page 4.14).



## Right Side Stalk

### Windscreen Wiper Control

- [1] - OFF.
- [2] - Intermittent Wipe.
- [3] - Normal Speed Wipe.
- [4] - Fast Wipe.



### Demand Wipe

Pull the stalk forwards.

 The windscreen wipers will return to their park position if the ignition is set to OFF or the bonnet is unlatched, regardless of the right stalk position.

**Speed Sensitive Wipe** - If the wipers are at fast wipe, when the vehicle slows down (below 11 km/h) the wipers will go to normal wipe speed.

If the wipers are at normal speed when the vehicle slows down (below 11 km/h) the wipers will go to intermittent wipe (position 2).

As soon as the vehicle speeds up (above 15 km/h) the wipers will return to their original setting.

### Windscreen Wiper Delay Control -

Intermittent wipe time delay increases or decreases in six steps (B). Sixth position gives the shortest delay between wipes.

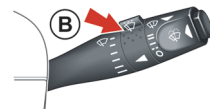

**Windscreen Washer Control** - Press the button (C) for more than one second to operate the windscreen washers.

Operation continues until the button is released. When released the washers stop immediately but the wipers continue for a few strokes, ending with a pause and then a final wipe.

If used during normal wiper operation, the wipers operate continually irrespective of the washer operation.

**Headlamp Washers** - Headlamp washers will operate automatically, once per journey (each ignition ON), if the windscreen washers are operated and the headlamps are ON.



## Master Lamp Switch

[1] - All external lamps OFF.

[2] - Side, side marker, rear and registration plate lamps ON.

[3] - With the vehicle key at position 'II' in the ignition control, Headlamps ON, in addition to the side, side marker, rear and registration plate lamps.

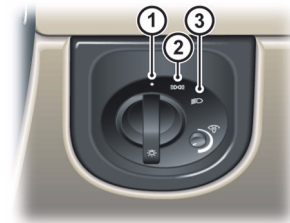

### Lamps ON Warning

If the vehicle side lamps are ON, and the drivers door is opened after the vehicle key has been removed from the ignition control, an audible warning will sound for a period of five minutes. To stop the audible warning set the lamps to OFF. The audible warning will also stop when the driver's door is shut - the lamps will stay ON.

### Day Time Running Lamps

(Denmark, Norway and Sweden only)

The dipped beams and side lamps are permanently ON.

### Instrument Brightness

During the daylight hours the level of instrument brightness defaults to maximum brightness. During the twilight and night time hours a twilight sensor (A (located in the centre stack)) automatically reduces the level of brightness to a preset level.

 *If the twilight sensor is covered the level of brightness will stay low as if in night time mode.*

The level of brightness can be reduced by using the rotary control (B). If the brightness level has been adjusted, the twilight and night time brightness level will return to the previous setting on the rotary control, each time the sensor picks up the twilight hours.

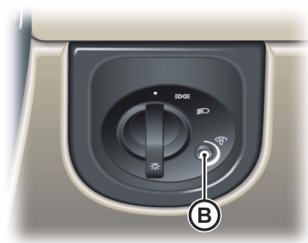

Push the rotary control in and release to enable the control. Push in and release to lock the control.

### Vehicle Horn

To sound the horn press the centre pad of the steering wheel at any of the positions shown.



## Trip Computer

Press the button (A) for less than three seconds cycles through the trip computer functions one at a time. Trip computer information is viewed in the message centre (right).

 If an information message shows, after reading and acting on the information provided press the **READ** button (B) to return to the trip display.

**Range** - Estimated travel distance with fuel available (no reset). The minimum distance shown will read 20 km. Below this distance will show '- - -'.

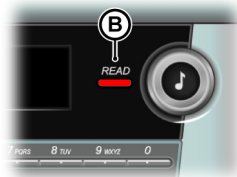

**Average Fuel** - Average fuel consumption since last reset. Press A for more than three seconds but less than five seconds to reset. Press A for five seconds or more will reset both the average fuel consumption and average speed. INFOCENTER IS RESET will be shown in the message centre (right). Press the **READ** button to acknowledge the message.

**Instantaneous Fuel** - Shows the fuel consumption over the last three seconds of travel (no reset).

**Average Speed** - Shows the average speed since last reset. Press A for more than three seconds but less than five seconds to reset. Press A for five seconds or more will reset both the average speed and average fuel consumption. INFOCENTER IS RESET will be shown in the message centre (right). Press the **READ** button to acknowledge the message.



**Present Speed** - Shows the current vehicle speed.

 Driver aid only.

 Trip computer default screen.

**Tyre Pressure Monitor** - Shows the current tyre pressure for all tyres (Refer to 'Tyre Pressure Monitoring', page 4.17).

**Blank Screen** - Blank screen will show.

### Display Units

The display can be set to show metric or imperial units.





With the ignition ON press the **READ** button (C) and the Trip Computer button (D) together for two seconds to change the trip computer display units.



## Cruise Control

Cruise control can be used to maintain a selected vehicle speed, above 30 km/h, without having to use the accelerator.

- [1] **RES** - Resume the set speed retained in memory.
- [2] **SET** - Set the speed, accelerate or decelerate.
- [3] **ON/OFF** - Sets cruise control to ON or OFF.
- [4] **CAN** - Cancels cruise control but keeps the set speed in memory.



### Operation

**⚠ Warning: Only use cruise control when conditions are favourable, for example, straight, dry, open roads with light traffic.**

Use the **ON/OFF** switch (3) to set cruise control ON and OFF. When cruise control is ON 'CRUISE' will show in the message centre (left). When travelling at the desired speed, which must be above 30 km/h, press **SET** (+ or -) (2). Cruise control will engage and maintain that speed without the need to use the accelerator pedal.

**📖** Under certain conditions cruise control will automatically set to OFF (Refer to 'Cruise Control Automatic OFF', page 4.16).

**📖** Cruise control will automatically disengage when the brake pedal is pressed or when the vehicle speed falls below 30 km/h.

### Changing the Set Speed

There are three ways to change the set speed:

- Accelerate or decelerate to the desired speed then press **SET** (+ or -).
- Accelerate or decelerate to the desired speed by pressing and holding **SET** (+ or -) until the desired speed is obtained, then release.
- Accelerate or decelerate to the desired speed in steps of 2 km/h by briefly pressing and releasing **SET** (+ or -) until the desired speed is obtained.

### Resuming the Set Speed

**⚠** **RES** should only be used if the driver is aware of the set speed and intends to return to it.

**⚠** It is not recommended to resume set speed when a low gear is selected as excessive engine speeds will occur.

 Cruise control will not resume at speeds below 30 km/h. **RES** will not operate if the ignition has been set to OFF.

If the vehicle is accelerated above the set speed, then the set speed will be resumed when the accelerator pedal is released.

If **CAN** (4) is pressed, or the brake or clutch pedal is pressed, cruise control will disengage but the set speed memory will be kept. Press **RES** (1) and the vehicle will return to the set speed.

### Cruise Control Automatic OFF

Cruise control will automatically set to OFF and clear the memory when:

- The ignition is set to OFF
- A fault occurs. The cruise control system will set to OFF and cannot be used until the fault is cleared
- The park brake is applied
- Maximum vehicle speed is reached

Cruise control will automatically set to OFF but the set speed will stay in the memory when:

- The **CAN** button is pressed
- The brake pedal is pressed
- Vehicle speed falls below 30 km/h

- Neutral, Park or Reverse gear positions are selected
- The difference between the actual and set speed is too great
- When the set speed is above 144 km/h; cruise control will disengage automatically after approximately 20 minutes
- The accelerator pedal is used to accelerate beyond the set speed for too long a period

## Ambient Temperature

The ambient temperature (outside temperature) is shown in the top right corner of the Infotainment centre display.

 If the vehicle has been travelling and then is stopped in a shaded or enclosed area the ambient temperature may rise, this is due to the heat from the engine bay. The ambient temperature display will show the true ambient temperature once the vehicle is moving again or the engine bay cools down.

 If required the display units can be changed from °C to °F or °F to °C (Refer to 'Climate Controls', page 6.2).

## Tyre Pressure Monitoring

**⚠ Warning: Driving on a significantly under-inflated tyre causes the tyre to overheat and can lead to tyre failure. Under-inflation also reduces fuel efficiency and tyre tread life, and may affect the vehicle's handling and stopping ability.**

Each tyre should be checked monthly when cold, in the ambient air temperature that the vehicle is normally driven. Setting tyre pressures in a warm garage and then driving in a very low ambient may result in a low tyre pressure warning. Set the correct pressure recommended by the vehicle manufacturer on the vehicle placard or tyre inflation pressure label (if your vehicle has tyres of a different size than the size shown on the vehicle placard or tyre inflation pressure label, you should make sure of the correct tyre pressure for those tyres).

As an added safety feature, your vehicle has been equipped with a Tyre Pressure Monitoring System (TPMS) that sets a tyre pressure telltale (warning) symbol to ON (A) when one or more of the tyres is significantly under or over inflated. At the same time an image of vehicle in the message centre (right) will show which tyre(s) have low or high air pressure and the current tyre pressure. When the tyre pressure telltale comes ON, stop and check your tyres as soon as possible, and inflate or deflate them to the correct pressure.

 The TPMS is not a substitute for correct tyre maintenance, and it is the driver's responsibility to maintain correct tyre pressures, even if under-inflation has not reached the level to set the TPMS tyre pressure telltale symbol to ON.

### Malfunction Telltale

Your vehicle has also been equipped with a TPMS malfunction telltale to show when the system is not operating correctly. The TPMS malfunction telltale is combined with the tyre pressure telltale.

When the system detects a malfunction, the telltale will flash for approximately one minute and then stay ON. This sequence will continue upon subsequent vehicle start-ups as long as the malfunction exists.



When the malfunction telltale is ON, the system may not be able to detect or send tyre pressure as intended. TPMS malfunctions can occur for a variety of reasons, including the installation of replacement or alternate tyres or wheels on the vehicle that prevent the TPMS from operating correctly.

Always check the TPMS malfunction telltale after replacing one or more tyres or wheels on your vehicle to make sure that the replacement or alternate tyres and wheels allow the TPMS to continue to function correctly.

### Operation

**⚠ When a tyre pressure warning is detected reduce the vehicle speed to an appropriate safe level and stop at the first safe and convenient place to inspect the tyre(s).**

At each ignition ON there is a short delay before tyre pressures are received, from the wheel and tyre transmitters, and shown in the message centre (right).

If the tyre telltale symbol comes ON while driving, reduce speed to 48 km/h and stop in safe place as soon as possible. Check the status of the tyre(s) in the message centre (right):

## Warning One

### Telltale Symbol

Constant

### Message centre (right)

CHECK TYRES (for ten seconds) followed by an image which shows which tyre(s) is affected and the current tyre pressures.

### Fault

Tyre pressure below or above specification

### Action

Check the tyre pressure of the affected tyre(s). Set the tyre pressure to the manufacturer's recommended pressure, as shown on the tyre label located on the edge of driver's door or the B-Pillar.



## Warning Two

### Telltale Symbol

Flashing for 75 seconds then constant

### Message centre (right)

TYRE SYSTEM FAULT (for ten seconds) followed by an image which shows which tyre(s) is affected and the current tyre pressures or which transmitter is at fault.

### Fault

System failure or tyre transmitter fault

### Possible Cause

- The TPMS sensors have become defective
- Wheels and tyres have been installed which do not have TPMS sensors
- An unapproved accessory is interfering with the TPMS
- A general fault has been detected in the TPMS

### Action



Continue at a reduced speed of 48 km/h maximum. Have the control unit and the tyre transmitters checked at the earliest opportunity. Consult your Aston Martin Dealer

## Display Units

The display can be set to show metric or imperial units.

With the ignition ON press the **READ** button (C) and the Trip Computer button (D) together for three seconds to change the trip computer display units.





ASTON MARTIN



ASTON MARTIN



ASTON MARTIN



ASTON MARTIN



ASTON MARTIN



ASTON MARTIN

# Driving

Driving Safety.....	5.2	Anti-Lock Braking System.....	5.7
Starting the Engine .....	5.2	Park Brake .....	5.8
Automatic Transmission.....	5.3	Dynamic Stability Control .....	5.9
PRND Buttons.....	5.4	Adaptive Damping.....	5.11
Touchtronic Controls.....	5.5	Fuel Filling.....	5.12
Sport Mode.....	5.5	Catalytic Converters.....	5.13
Fault Conditions.....	5.6	Front and Rear Parking Assist.....	5.13
Footbrake .....	5.7	Rear Only Parking Assist.....	5.15
		Driving Techniques.....	5.15



ASTON MARTIN

# RAPIDE

Hand built for The Frankfurt Motorshow 2009

## Driving Safety

- Always wear your seat belt
- Never drive under the influence of alcohol or drugs
- Always obey all speed and traffic laws and regulations. Never drive faster than the posted speed limit or than conditions allow
- Be particularly careful driving on slippery or wet surfaces
- This vehicle is a high performance vehicle and has handling characteristics you may not be accustomed to. Familiarise yourself with the vehicle and always drive prudently, being aware of your own limitations and the limitations of the vehicle. As with other vehicles of this type, failure to operate the vehicle correctly can result in accident and injury
- Follow the maintenance schedule approved in this guide
- Never allow the vehicle to be driven by inexperienced drivers

## Starting the Engine

**⚠ Warning: Only use the vehicle key in the ignition control. Do not place any objects, including fingers, into the ignition control other than the vehicle key. Objects other than the vehicle key may cause the ignition control unit to fail.**

**⚠ In extreme low temperatures (15°C and below) do not allow the engine to 'rev' above 4000 rpm, while at standstill or when moving off, until the coolant temperature gauge reaches normal operating temperature. Revving the engine before fully warmed up may cause severe engine and transaxle damage.**

**⚠ Do not press the vehicle key while driving. If the key is pressed in and released the engine will stop. If the key is removed from the ignition control while driving the engine will stop but the steering lock will not engage until the vehicle has come to a complete stop.**

**⚠ The vehicle key must only be inserted into the ignition control with the two indents first, as shown. Attempting to insert the larger end first the key may damage the ignition control.**



**📖 Make sure that you are wearing appropriate footwear to efficiently operate the control pedals. Make sure that pedal movement is not restricted by floor mats or other objects trapped beneath pedals.**

**📖 Insert the key to position 'II' by using the flat of a finger, as shown.**

Check that the park brake is applied.  
Fully press the brake pedal down.

Insert the vehicle key into the ignition control and press the key fully in (the ignition control will show red), hold in until the engine starts then release.

The vehicle key will sit flush with the ignition control bezel while the engine is running. The ignition control will show a white light when the engine is running, and then fade out.

**📖 When moving straight to engine start the vehicle system will take short time (approximately 1.4 seconds) to complete a system check and release the steering lock before allowing the engine to crank.**





If the engine fails to start the vehicle key must be returned to position '1' to crank the engine again. **Press the key fully in, without depressing the brake pedal, and release.** The key will gently return to position '1'. Start the engine start procedure again.

### Starting From Cold

The Engine Control Module (ECM) automatically compensates for cold or warm start conditions and makes appropriate adjustments to the fuel and air mixture and ignition timing.

### Stopping the Engine

Press the vehicle key fully in and release. The engine will stop as the key returns to position '1'. Withdraw the vehicle key from the ignition control.



## Automatic Transmission

The Automatic transmission has two drive modes.

### Auto Drive Mode

In auto drive mode gearshifts are made using the Park, Reverse, Neutral and Drive (PRND) buttons mounted on the centre stack. While driving forward gearshifts are made automatically according to various driving parameters, i.e. road speed, current selected gear and accelerator demands. When the vehicle is stationary the transmission will select first gear, ready to move off immediately when the accelerator is pressed.

While in auto drive mode move to touchtronic mode at any time by pulling back on either the upshift or downshift gearshift paddles, mounted behind the steering wheel. As a paddle is pulled back a gearshift will occur, this will be an upshift or downshift according to which paddle is pulled.

### Kick-Down

In auto drive mode kick-down is used in circumstances where rapid acceleration is required, i.e. when overtaking. Kick-down operates when the accelerator pedal is quickly and fully depressed, causing the transmission to change down to the lowest gear possible to achieve maximum acceleration. The gear engaged depends on the road speed at the time of kick-down.

### Touchtronic Mode

In touchtronic mode forward gears and Neutral are selected by using the paddles located behind the steering wheel. Reverse and park selected by using the PRND buttons.

While in touchtronic mode move to auto drive mode at any time by pressing the **DRIVE** button.

 *Neutral can also be selected by pressing the **NEUTRAL** button.*

## PRND Buttons

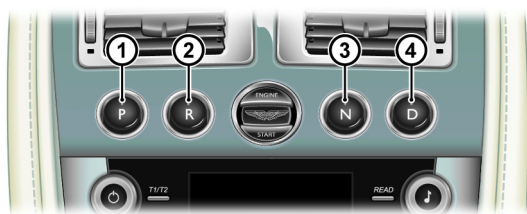

**[1] PARK** - Press and release to select park once the vehicle is stationary. The transmission will mechanically lock. If the vehicle key is moved to position '0' or removed from the ignition control while the vehicle is at a standstill, the transmission will automatically select park.

**!** *Always make sure that the park brake is ON.*

**📖** *It is not possible to select Park above 2 km/h.*

**[2] REVERSE** - When stationary and with the footbrake applied, press and release to select Reverse. When reverse is selected, **R** will show red in the Gear Position Indicator Display (GPID) (B) and a warning will be heard.

**[3] NEUTRAL** - When stationary and with the footbrake applied, press and release to select Neutral.

**[4] DRIVE** - When stationary and with the footbrake applied, press and release to select forward gears.

**📖** *If the brake pedal is not pressed the message centre (right) will show PRESS BRAKE PEDAL and a warning will be heard.*

The message centre (left) (A) shows the current gear selection R, D1, D2, etc., while the Gear Position Indicator Display (GPID) (B) shows D (Drive), R (Reverse) or P (Park) according to current gear position. While in auto drive mode the GPID will show 'auto'.

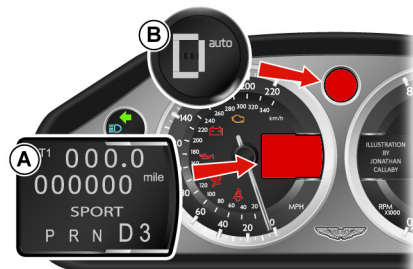

## Vehicle Rocking Motion

If the vehicle speed is less than 4 km/h, reverse may be selected from drive, without pressing the brake pedal, to create a vehicle 'rocking' motion i.e. to enable vehicle movement out of mud, snow, etc. If 4 km/h is exceeded then the transmission will automatically select Neutral.

## Touchtronic Controls

Forward gearshifts are selected by pulling back and releasing the gearshift paddles mounted on the steering column. Neutral is selected by pulling back both paddles together and releasing. Park and reverse are selected by using the centre stack mounted PRND buttons.

[1] - Downshift paddle.

[2] - Upshift paddle.

 Neutral can also be selected by pressing N.

From park, reverse or neutral, and with the footbrake applied, pull back on either the upshift or downshift gearshift paddle to enter touchtronic mode. As the vehicle speed increases and decreases, make upshifts and downshifts by pulling and releasing the upshift or downshift gearshift paddle.

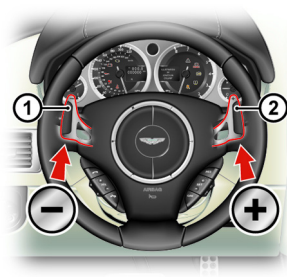

If no gearshift has been requested by pulling back on a paddle, upshifts and downshifts will occur automatically if the engine speed rises or lowers to its maximum or minimum operating limits (unless the transmission is in sport mode (Refer to 'Sport Mode', page 5.5)). When stationary select neutral by pulling back on both gearshift paddles simultaneously. When selecting neutral from park the brake pedal must be depressed.

The message centre (left) shows the actual gear currently selected R, D1, D2, etc. The GPID also shows the current gear selected but may show the target gear when a gearshift is in progress (either 1, 2, 3, 4, 5, 6, R or P). The GPID will show 'touch'.



## Sport Mode

Sport mode can be selected while in auto drive or touchtronic modes. Press and release the Sport button (A) to enter or exit sport mode. The Sport button LED will come ON and SPORT will show in the message centre (left) when sport mode is ON.

When Sport mode is ON while in:

**Auto Mode** - Upshifts and downshifts occur at higher engine speeds to provide a sportier drive.

 If sport mode is selected while in auto drive sixth gear a downshift to fifth gear will occur (this will not happen if cruise control is ON) and sixth gear will be inhibited until sport mode is set to OFF.

**Touchtronic Mode** - Automatic upshifts are prevented, the upshift paddle must be pulled back and released to make an upshift (downshifts will occur automatically if the engine speed lowers to its minimum operating limits).



To maintain speed and smoothness while driving in touchtronic sport mode, the current gear, shown in the GPID, will flash red at the optimum time to make an upshift.



 To protect the engine and transmission, when in touchtronic mode, an automatic upshift from fifth to sixth gear will occur when the engine speed reaches 6600 rpm.

### Maximum Engine Speed

The maximum safe engine speed is 6,850 rpm. If this speed is exceeded, fuel supply to the engine is reduced. As the engine speed reduces back to a safe level, fuel supply is progressively restored.

## Fault Conditions

### Limp-home Mode

If a fault is detected the vehicle will go into one of three limp home modes:

**Electrical** - GEARBOX FAULT REDUCED FUNCTION will show in the message centre (right). Touchtronic and sport modes will be disabled. Gearshifts will still be possible but shift quality will be degraded.

 In certain circumstances forward drive will be restricted to a fixed gear.

Contact your Aston Martin Dealer.

**Reduced Engine Performance** - REDUCED ENGINE PERFORMANCE will show in the message centre (right). Engine performance will be restricted. Contact your Aston Martin Dealer.

**Mechanical** - LIMPHOME NO GEAR CHANGE POSSIBLE will show in the message centre (right) and a warning sound will be heard. If travelling forwards in auto drive or touchtronic mode the vehicle will go into a locked gear (third or fifth depending on vehicle speed).

 **Do not attempt to change gear position while in mechanical limp home mode. If a gearshift request is detected at a speed below 20 km/h the engine will stop and the parklock will come ON.**

 **At a speed above 20 km/h the request and any other transmission request will be rejected and the vehicle will continue in third or fifth gear.**

If entering mechanical limp home mode in any position other than auto drive or touchtronic mode the parklock will come ON (Refer to 'Parklock Override', page 11.15). Contact your Aston Martin Dealer.

## Footbrake

The footbrake operates through a vacuum boosted, dual (diagonal split) circuit, hydraulic system incorporating an Anti-lock Brake System (ABS).

**⚠ Warning: In the event of a brake failure bring the vehicle to a halt as soon as it is safe to do so. Do not continue to drive.**

**⚠ If vacuum boost fails or one circuit fails the footbrake will still operate but with greater pedal pressure, increased pedal travel and longer stopping distances.**

**⚠ After a long drive over salted or gritted roads or if driving in heavy rain, through water or a vehicle wash, the braking action may be delayed and increased braking pressure may be required.**

 Vacuum boost is only available while the engine is running.

### Brake Warnings

**⚠ Warning: If the brake warning symbol comes ON, you should immediately be prepared for possible increased stopping distances and possible partial failure of the braking system.**

While driving, if the brake warning symbol  BRAKE comes ON, it shows either that:

- The park brake is not fully released
- The brake pads require regular maintenance
- The brake fluid level has fallen below an acceptable level
- The Electronic Brake Distribution (EBD) system has stopped working.

 A warning message will show in the message centre (right).

Stop, as soon as possible in a safe and convenient place. Apply the footbrake and make sure that the park brake is fully released. If the park brake is fully released and the warning symbol stays ON, **do not drive** the vehicle. Contact the nearest Aston Martin Dealer. It is essential that the brake system is checked immediately, preferably by an Aston Martin Dealer.

 *Brake Noise: The high performance brake system used on this vehicle is designed to provide optimal braking under all operating conditions. However, under all driving conditions an inherent characteristic of this braking system is some brake noise. Certain combinations of speed, braking forces and ambient conditions may also cause the brakes to squeal.*

## Anti-Lock Braking System

The Anti-lock Braking System (ABS) helps prevent the road wheels from locking and skidding during emergency braking. This also assists the driver in maintaining steering and directional stability.

If, in an emergency braking situation, the braking force applied begins to exceed the tyre to road adhesion, the ABS operates to prevent the road wheels locking. When this happens a pulsating effect is felt through the brake pedal. This is a normal ABS effect.

### Safety

In all cases it is always the drivers responsibility to drive safely according to the law and with due regard to prevailing conditions. The fact that a vehicle is equipped with ABS must never allow the driver to be tempted into taking risks which could affect his or her safety or that of other road users.

The addition of ABS cannot overcome the consequences of trying to stop in too short a distance, cornering at too high a speed, or the risk of aquaplaning (where the tyres are prevented from contacting the road surface by a layer of water).

The driver should always take road conditions into account. A slippery road surface always requires more braking distance for a given speed, even with ABS. Possible extensions of stopping distance compared to locked wheels may occur during ABS operation on slushy snow, gravel, sand or certain heavily corrugated or ridged warning sections of road surfaces.

If any braking system malfunction occurs, immediately have the Braking and ABS systems checked by your Aston Martin Dealer.

### ABS Warning

**⚠ Warning: If the ABS warning symbol comes ON, you should be aware that wheels could lock during extreme braking or when braking on slippery surfaces.**

ABS is monitored for correct operation while the ignition is ON. If a fault is detected, the ABS warning symbol  will come ON and the ABS will be partly or fully OFF. Normal braking will continue to function without ABS.

In the event of an ABS fault, consult your Aston Martin Dealer immediately.

## Park Brake

**⚠ Do not rely on the park brake to hold the vehicle stationary if the brake system warning symbol is ON or flashing. Contact your Aston Martin dealer.**

The park brake on this vehicle is electric and operates in the same way as a manual parking brake. Pull the switch up to apply the park brake and push the switch down to release the park brake.

### Apply and Release the Park Brake

With the vehicle stationary, pull the park brake switch (A) up and release. The red park brake warning symbol in the instrument cluster

will come ON  BRAKE (if the ignition is ON) when the park brake is fully applied. The stop lamps will not come ON.

 When stationary the park brake can be applied at any time if not already applied.

**⚠ The park brake operates on the rear wheels of the vehicle. Secure parking of the vehicle is dependent on being on a hard and stable surface.**

To release the park brake the ignition control must be at position 'II'. First apply pressure to the foot brake then press down on the park brake switch and release.

### Drive Away Release

**⚠ Do not exit the vehicle with the engine operating and the transmission in D (drive) or R (reverse). Always select P (park) before exiting the vehicle. If the transmission is left in D or R the vehicle could overcome the park brake and start to move.**

When parked with the park brake applied, select a forward or reverse gear, press the throttle pedal and the park brake will release as the vehicle moves forwards or backwards.

The park brake will not release when moving from a standstill if a vehicle door or the boot is open - in this case the park brake must be released with the park brake switch.



## Park Brake Operation While Moving

**!** *Driving the vehicle with the park brake applied or repeated use of the park brake to slow the vehicle can cause serious damage to the brake system.*

In an emergency, with the vehicle travelling at more than 6 km/h, pull up on the park brake lever and hold to give a gradual reduction in speed. The brake warning symbol will come ON, a warning sound will be heard and CAUTION PARK BRAKE APPLIED will show in the message centre (right).

Release the switch to cancel the park brake application.

## Park Brake Faults

### Low Battery Voltage

If the battery voltage is too low, the park brake cannot be put ON or OFF. Connect an auxiliary battery if the battery voltage is too low.

### System Faults

If a fault in the system is detected, PARK BRAKE FAULT or CANNOT APPLY PARK BRAKE will show in the message centre (right). Contact your nearest Aston Martin Dealer.

If the battery has been discharged or disconnected, APPLY FOOT AND PARK BRAKE will show in the message centre (right) when the ignition is next ON. Press the foot brake down and pull the park brake lever up to put the park brake ON, this will reset the park brake system.

## Dynamic Stability Control

**!** *Warning: It is the drivers responsibility to drive safely according to the law and with due regard to prevailing conditions.*

**!** *Warning: Dynamic Stability Control (DSC) must never let the driver be tempted into taking risks which could affect his or her safety or that of other road users. DSC cannot overcome consequences of applying too much engine power for prevailing conditions.*

Dynamic Stability Control (DSC) is a system designed to enhance driving safety by improving the vehicle handling when the tyres are at the limits of their grip capabilities. This is achieved through the reduction of engine torque and strategic application of the brakes at individual wheels.

## Driver Interface and Control

**!** *If repair or replacement of the steering or other surrounding equipment is necessary, always refer to your Aston Martin Dealer. If the centre position of the steering deviates, the DSC may not operate correctly because there is a sensor in the steering system which detects steering wheel position.*

⚠ **The DSC system may not operate correctly when using tyre chains or a temporary spare tyre.**

⚠ **Use tyres of the same manufacturer, brand, tread pattern and correct size specified for this vehicle on all four road wheels. Do not mix worn tyres.**

DSC has three modes of operation:

**ON** - The DSC system sets to ON each time the engine is started. DSC is controlling engine torque and applying strategic application of the brakes at individual wheels.

While the DSC system operates to correct the vehicle stability the

DSC symbol  on the instrument cluster, will flash.



**SPORT MODE** - Press and hold the DSC button (A) for four seconds and release. DSC SPORT MODE SELECTED will show in the message centre (right) and the DSC symbol will be ON in the instrument cluster. This raises the thresholds at which the DSC system operates. While the DSC system operates to correct the vehicle stability the DSC symbol will flash.

**OFF** - When in sport mode press and hold the DSC button for four seconds and release to set the DSC to OFF. DSC OFF can not be selected from DSC on. DSC FUNCTION OFF will show in the message centre (right) and the DSC symbol will show in the instrument cluster. DSC is no longer controlling engine torque and applying strategic application of the brakes at individual wheels. At any time while in sport or off mode, press and release the DSC button to start DSC.

 *The DSC button LED and the DSC symbol (instrument cluster) will come ON when the system is set to sport or off mode.*

### Fault Signs

A malfunction in the DSC control system will be shown by the following:

- The DSC symbol in the instrument cluster will come ON
- A warning message will show in the message centre (right) depending on the fault detected

### Traction Control

 **Warning: It is always the drivers responsibility to drive safely according to the law and with due regard to prevailing conditions.**

 **Warning: Traction control must never let the driver be tempted into taking risks which could affect his or her safety or that of other road users.**

 **Warning: Traction control cannot overcome consequences of applying too much engine power for prevailing conditions.**

Traction control is a function of DSC, and is operated in association with the DSC system. Traction control prevents excessive wheel spin at standing starts, or during acceleration. Wheel spin is usually caused by excessive use of the accelerator pedal, or slippery, loose or bumpy road surfaces.

To prevent excessive wheel spin and maintain vehicle stability in such situations the traction control system will:



- Brake either of the driven wheels when they start to slip
- And, or, adapt the engine torque to a level corresponding to the traction available on the road surface

 *These symptoms are normal and will clear as wheel spin is eliminated and normal engine power is restored.*

 *If cruise control is on it will automatically go OFF when traction control is operating.*

During operation, the DSC warning symbol will flash. The driver may experience a loss in power or temporary 'misfire' as engine power is reduced.

If traction control cuts in when driving on extended icy or slippery surfaces, reduce engine power as necessary until the DSC warning symbol goes OFF.

Traction control is always ON when DSC is ON.

## Adaptive Damping

The Adaptive Damping System (ADS) is continuously ON, adjusting the damping characteristics at all four corners, according to vehicle body movement and monitored driver inputs. Sensors on the vehicle constantly measure the vehicle body movement and driver inputs – braking, steering, vehicle speed and throttle displacement. This information is then supplied to the ADS control unit which calculates the optimal damper characteristic at each corner at any given moment.

 *ADS is independent of the DSC system.*

ADS has two modes of operation:

**Normal Mode** - At ignition ON the ADS system defaults to normal mode which gives damping characteristics for everyday driving.

**Sport Mode** - Press and release the ADS button (A) to start sport mode, which gives damping characteristics for a firmer ride.

While driving move to normal (button LED OFF) or sport (button LED ON) mode by pressing and releasing the ADS button.



## Fuel Filling

Press and release the fuel flap button (A) to open the capless fuel filler flap (B). If the filler flap will not open when the release button is pressed, open the filler flap manually.

 *The fuel tank filler neck has a restricted opening which will only accept the fuel supply nozzle of unleaded fuel pumps.*



The fuel system will not let the fuel tank overfill but there will be times when the fuel nozzle will shut OFF prematurely. If this happens only try to fill the fuel tank one more time, continued attempts will result in fuel spillage. Wait 10 seconds before removing the refuelling nozzle.

### Emergency Fuel Fill

An emergency fuel fill funnel is located in the boot tool kit. It can be used to fill the fuel tank from a non standard size gerry can.

### Fuel Filler Flap Emergency Release

If the filler flap will not open when the release button is pressed, open the filler flap manually. Remove the boot LH trim panel (C) to access the manual fuel filler flap release. Push the lever (D) towards the front of the vehicle to open the filler flap.

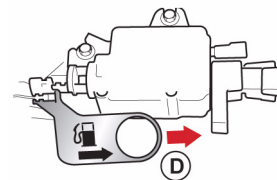
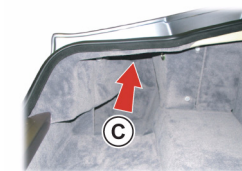

### Fuel Cut-OFF

In the event of a vehicle accident the vehicle electronics will enter crash mode. Power to the fuel pumps will stop, thereby reducing fire risk.

## Catalytic Converters

**⚠ Warning: Do not park over dry grass, leaves or other combustible material. Significant fire risk exists because of residual heat in the catalytic converters.**

**⚠ Warning: Do not drive through deep water. Rapid cooling of catalysts may cause them to break up.**

Catalytic converters convert harmful exhaust gasses into less noxious substances and so reduce environmental pollution. They operate at high temperatures and continue to radiate a considerable amount of heat after the ignition has been set to OFF.

Leaded fuel will cause irreparable damage to catalytic converters. If leaded fuel is inadvertently added to the fuel tank **do not start the engine, do not drive the vehicle.** Contact your Aston Martin Dealer immediately.

## Front and Rear Parking Assist

(If installed on your vehicle)

**⚠ Warning: Parking assist does not replace need for total vigilance and caution when parking or reversing.**

**⚠ It is always the driver's responsibility to detect obstacles and estimate the vehicle's distance from them. Some overhanging objects, barriers, thin obstructions or painted surfaces which could possibly cause damage to the vehicle may not be detected by the system. Always be vigilant when reversing.**

**⚠ The rear sensors are not ON when neutral is selected, therefore care should be taken if moving the vehicle as the warning sound will not be heard.**

**⚠ Do not clean the sensors with abrasive or sharp objects.**

**📖 For reliable operation, the sensors in the front and rear bumpers should be kept free from ice, frost and grime.**

**📖 When using a high pressure spray the sensors should only be sprayed briefly and not from a distance of less than 200 mm. Do not clean the sensors with abrasive materials.**

A warning will be heard when driving forwards or rearwards, if objects are detected within range of the vehicle.

## Operation

**⚠ If, for example, you are driving within a confined space such as a home garage, the outer sensors will detect the side walls and after three seconds the tone will stop. However, as movement continues, the inner sensors will eventually detect the rear wall and will start the tone again.**

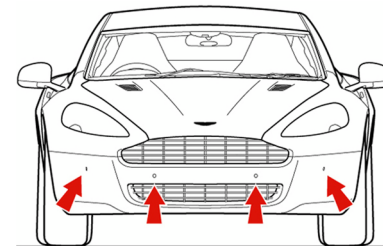

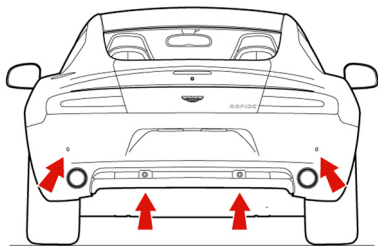

**!** *In heavy rain or similar adverse conditions, the rear parking assist sensors may not always be able to accurately measure distance to close objects. A fully laden vehicle or irregular obstacles may also cause inaccurate measurements.*

The parking assist system defaults to OFF when the ignition is set to ON. The system comes ON when reverse gear is selected, or if the parking assist button (A) is pressed at speeds below 15 km/h.

The system will set to OFF when the vehicle moves forwards above 15 km/h. The parking assist button LED will come ON when the system is set to ON. The LED will flash if a fault is detected in the system.

If an obstacle is detected at the front or rear of the vehicle, a series of beeps will be heard from the front or rear speaker respectively, which increases in rate as the vehicle nears the obstacle.

The beep becomes a continuous tone when an obstacle is detected at or within approximately 300 mm from the rear or 250 mm from the front of the vehicle.

If the system has a fault a single three second tone will be heard (only once per ignition cycle) and the parking assist button LED will blink when reverse gear is selected or the ignition is set to ON. The system is automatically disabled when a fault is detected.



**!** *Parking assist may sound spurious tones if it detects an ultrasonic frequency using the same band as the sensors.*

**!** *The system consists of inner and outer sensors. When manoeuvring forward into a garage, etc., the front outer sensors will cease detection if they detect a stationary or receding object for three seconds or more, this allows detection directly at the front of the vehicle in this type of manoeuvre.*

## Rear Only Parking Assist

(If installed on your vehicle)

**⚠ Warning: Rear parking assist does not replace need for total vigilance and caution when parking or reversing.**

**! When parking or reversing make full use of rearward vision and all mirrors to be aware of persons or objects in the vicinity of the vehicle. Take appropriate measures to protect them from danger.**

**! In heavy rain or similar adverse conditions, the rear parking assist sensors may not always be able to accurately measure distance to close objects. A fully laden vehicle or irregular obstacles may also cause inaccurate measurements.**

Rear parking assist assists in detecting obstructions as the vehicle is reversed towards them. The system is ON when reverse gear is selected. When the system is operating an intermittent 'beep' signal will be heard. The 'beep' frequency increases in pitch and persistence as the vehicle reverses to an obstruction.

**📖** The 'beeps' start at approximately 1.7 m from any obstruction. The 'beep' becomes continuous at distances less than 30 cm.

**📖** If reversing into a confined area, i.e. a home garage, the rear parking assist outer sensors will detect the side walls and, after 3 seconds, the 'Beep' sequence will stop. As reversing continues the rear parking assist inner sensors will detect the rear wall or obstruction and the 'beep' sequence will start again.

Set parking assist to OFF by pressing the parking assist button (A) if required (button LED OFF). For reliable operation, the parking sensors should be kept free from ice, frost and grime.

## Driving Techniques

Procedures for driving this vehicle may be unfamiliar to many new owners. To make sure that you have a safe and enjoyable entry into this new phase of Aston Martin motoring please take time to safely acquire the necessary new driving skills. Practise in safe, lower speed conditions before investigating the high performance potential of the vehicle.

Performance Driving Courses are available to enable customers not only to understand the control functions of their vehicle but also the basic principles of Performance Driving.

Contact your Aston Martin Dealer for further information.

### Wet Conditions

When driving in wet conditions, water can build up under your tyres so that they ride on a layer of water. This is called aquaplaning or hydroplaning. When this happens, you have little or no control.

Aquaplaning is more prone to happening at higher road speeds if there is a lot of water on the road and particularly if the tyres are also under inflated or approaching minimum tread depth.

It is important to take bends or curves at a safe, reasonable speed, particularly when driving on wet or slippery road surfaces.

**Slow down when it is raining.**

### Track Days

Before using this vehicle on track days contact your Aston Martin Dealer for vehicle set up, service parts and recommendations.

### Driving Through Deep Water

**⚠ If in any doubt whether to drive through deep water, always take the side of caution to avoid potentially costly damage to the vehicle's engine or other essential systems.**

If driving on flooded roads, through deep or standing water is unavoidable, proceed with extreme caution, especially when the depth is not known. Never drive in water deeper than the lower edge of the front bumper. Water can be splashed up into the engine air intakes located in the front upper grille and cause extensive damage to the engine or the vehicle may stall.

When driving through water, traction or brake capability may be limited. Once through the water, always dry the brakes by driving slowly while applying light pressure on the brake pedal.

 *Waves caused by other vehicles or natural causes can also splash water in the engine air intakes.*

### Running-In

This vehicle is fully hot tested during manufacture and no special running-in procedures are necessary. Nevertheless it is recommended to limit engine loads (e.g. by accelerating gently and by using lower gears on steep hills or when negotiating tight turns) during the first 1500 km.



ASTON MARTIN

# Climate Control

Operating Tips .....	6.2
Climate Controls .....	6.2
Airflow Modes .....	6.4
Automatic Operation .....	6.6
Manual Operation .....	6.6
Rear Environment .....	6.7



## Operating Tips

- A solar sensor is installed on top of the instrument panel, this should not be covered when driving
- The intake grille of the in-vehicle temperature sensor is located in the driver's knee bolster, close to the centre console. To maintain the optimum temperature this grille should not be obstructed
- Moisture which forms on the evaporator in the air conditioning unit is discharged via a drain tube onto the road. After stopping, small puddles of water may form underneath the vehicle. This is normal and does not show a system malfunction
- Operate the climate control system with the engine operating
- Clear all obstructions like leaves, snow and ice from the bonnet and the air inlet in the front grille to improve the system efficiency
- Windows can fog up easily in humid weather. Use the climate control system to demist the windows
- To help demist the windows, operate the air conditioner to dehumidify the air
- Use the 'outside air' position in normal conditions. The 'recirculated air' position should be used temporarily when driving on dusty roads or for quick cooling or heating of the interior

- If the vehicle has been parked in direct sunlight during hot weather, open the windows to let warm air escape, then close the windows and operate the climate control system
- Operate the climate control system at least once a month to keep internal parts lubricated
- Have the climate control system checked before the weather gets hot. If the climate control system is low on refrigerant or has a malfunction, consult your Aston Martin Dealer
- This vehicle is equipped with a pollen filter. It is necessary to change the filter periodically as shown in the scheduled maintenance. Consult your Aston Martin Dealer

## Climate Controls

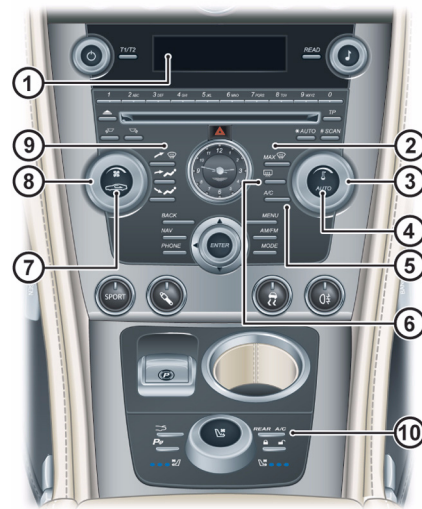



[1] **DISPLAY** - Shows options, menus and information.

[2] **MAX**  - Press for maximum defrost or demist ON or OFF. Outside air intake is automatically selected and air conditioning is automatically started.

[3] **TEMPERATURE** - Set the required in vehicle temperature. Turn clockwise for hot and counterclockwise for cold. The selected temperature is shown on the **DISPLAY**.

[4] **AUTO** - Press for automatic climate control operation (Refer to 'Automatic Operation', page 6.6).

[5] **A/C** - When in manual mode press and release to set the air conditioning ON or OFF.

[6] **HEATED REAR WINDOW** - Press to operate the rear window heater. Goes OFF after 20 minutes if not manually set to OFF. When the heated rear window is ON the door mirror heaters will work for 6.5 minutes, then go OFF.

 **Warning: Do not select recirculated air in cold or rainy weather, it can cause the interior glass to mist up.**

[7] **AIR CIRCULATION** - Controls the source of air entering the vehicle. Press to select recirculated air (button LED ON). Press again to select outside air as source.

Use the recirculated air position when going through tunnels, driving in congested traffic (high engine exhaust areas) or when maximum cooling is required. On start up the default position is outside air as source. Use this position for normal conditions and demisting.

[8] **FAN SPEED** - Turn to set the required fan speed (clockwise for fast speed and counterclockwise for low speed). The fan speed is shown on the **DISPLAY**

[9] **AIRFLOW** - Select the required airflow. The selected air flow mode is shown on the **DISPLAY** (Refer to 'Automatic Operation', page 6.6).

[10] **REAR AC** - Press and release (LED ON) to operate the rear environment climate with the front controls (rear controls locked). Control defaults back to front climate after five seconds (LED OFF) if no climate control buttons are used (rear controls unlocked). Press and hold for three seconds and release to lock or unlock the rear environment climate controls.

## Display Units

To change the **DISPLAY** units from °C to °F or °F to °C.

Press and hold in buttons 1 and 6 (A). Insert the vehicle key in the ignition control and move to position 'II' (ignition ON), then release the two buttons.



## Airflow Modes

Press and release each button for an airflow mode. By pressing one or more buttons at a time, five airflow modes are available.



Mode	Button(s)
Windscreen and Door Windows <sup>1</sup>	A
Face Only	B
Feet Only <sup>2</sup>	C
Windscreen, Door Windows and Feet <sup>3</sup>	A+C
Face and Feet	B+C

1. In addition a small bleed of air is directed into the face vents.
2. In addition a small bleed of air is directed to the face vents, the windscreen and door windows.
3. In addition a small bleed of air is directed into the face vents.

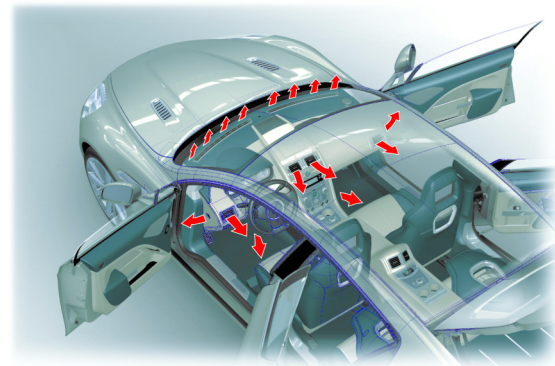

## Adjusting the Vents

To adjust the air flow vents:

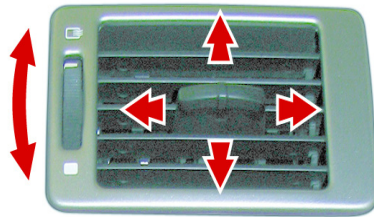

## Solar and Temperature Sensors

The automatic air conditioner function measures inside and outside temperatures, and sunlight. It then sets the interior temperature accordingly. To maintain effective operation do not obscure the following sensors:

- [1] - Solar sensor.
- [2] - In-vehicle temperature sensor.

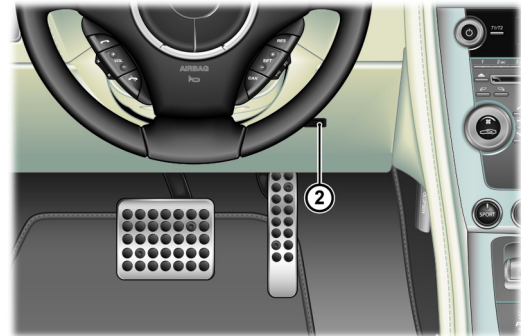
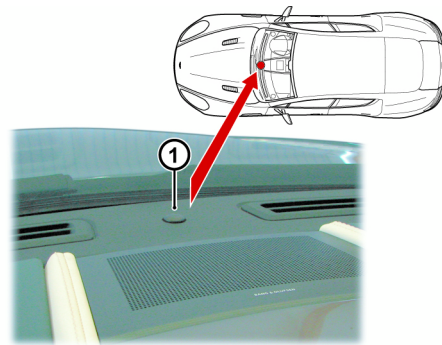



## Automatic Operation

Press **AUTO**. Using the **TEMPERATURE** dial set the required in-vehicle temperature (read the actual temperature setting in the top left of the **DISPLAY**). The **A/C** button LED will come ON.

Adjustments to fan speed, air flow and air re circulation will be made automatically according to the set temperature, interior and exterior conditions.

 *Maximum fan speed will not be available until the engine has reach its normal operating temperature.*

 *When using the air conditioner, mist may come out from the vents. This is not a sign of trouble but a result of humid air being suddenly cooled.*

 *If resetting climate control functions other than the fan speed, the fan speed will stay set as in automatic mode. Adjustments to the fan speed will cancel Auto Mode.*

### Defrost and Demist

 **To defrost or demist the windscreen on vehicle start up in extreme cold weather conditions, operate the engine at 1500 rpm. Always make sure that the transmission is in Park and the park brake is applied.**

Press **MAX**  . The outside air intake is automatically selected, the temperature is set to maximum and A/C is started.

To cancel Automatic defrost or demist either:

- Press **MAX**  again
- or
- Press **AUTO**
- or
- Press any of the airflow mode buttons

## Manual Operation

Set the required:



- Fan speed
- Temperature
- Air flow

If dehumidifying is required, press the **A/C** button (button LED ON). To stop dehumidifying press **A/C** button (button LED OFF).

 *When using the air conditioner, mist may come out from the vents. This is not a sign of trouble but a result of humid air being suddenly cooled.*

 *Setting the temperature to maximum high or low will not provide the required temperature at a faster rate. To prevent cool air blowing from the vents when heating immediately after starting a cold engine, the amount of airflow is reduced until the air warms up.*

 *The vehicle heater will continue to produce the selected temperature regardless of in-vehicle conditions.*

 *When maximum cooling is required, set the **TEMPERATURE** dial to the extreme cold position and press the **AIR CIRCULATION** button to the re circulated air position ( will show in the **DISPLAY**), then set a fast fan speed.*

### Defrost and Demist

**!** *To defrost or demist the windscreen on vehicle start up in extreme cold weather conditions, operate the engine at 1500 rpm. Always make sure that the transmission is in Park and the park brake is applied.*

Press **A/C**. Press the   airflow button.

Set the required:

- Temperature
- Fan speed

 *If the engine is cold the air conditioning will not start up until the engine has started to warm up.*

 *For maximum defrost or demist set the temperature and fan speed dials to maximum.*

### Control of the Rear Climate

Press and release **REAR A/C** to set the rear climate from the front controls. Once pressed set the fan speed, temperature, airflow mode<sup>1</sup> and A/C for the rear environment. If no buttons are pressed, after seven seconds the control returns to the front.

Press **REAR A/C** and hold for two seconds and release to lock or unlock the rear controls. When the rear climate controls are locked the **REAR A/C** LED will show. When locked the rear controls can not be used and the interior climate is set only by the front controls.

### Controls



<sup>1</sup>. Screen mode is not available.

**[1] DISPLAY** - Shows the fan speed or temperature when selected.

**[2] DIAL** - When temperature, fan speed or seat climate control buttons are selected, turn to set temperature or fan speed.

**[3] MODE** - Press and release to select temperature or fan speed. Defaults to fan speed.

**[4] A/C** - Press and release to set the rear air conditioning to ON or OFF.

**[5] AIRFLOW** - Select the required airflow.

### Operation

When the rear climate system is unlocked at the front controls, set the fan speed, temperature, air flow and A/C for the rear environment from the rear controls.

 The **DISPLAY** will not show when control is from the front.

 Rear air conditioning is only available when the front air conditioning is set to ON.

 Maximum fan speed will not be available until the engine has reached its normal operating temperature.

Press **MODE** to select fan speed or temperature. Turn the **DIAL** to set the required fan speed (clockwise for faster and counterclockwise for slower) or temperature (clockwise for warmer and counterclockwise for cooler).

Press and release each **AIRFLOW** button to select an airflow mode. By pressing one or more buttons at a time, three airflow modes are available. When no airflow mode is selected the rear climate system sets to OFF.

 When no airflow mode button is selected there is a small time delay before the rear system sets to OFF.

To assist the front climate control when the interior is either too warm or too cold, when the front climate system is set to either **AUTO** and maximum high or **AUTO** and maximum low temperature the rear system follows as detailed, regardless of it's current state:

 The front climate controls must be set to maximum high or maximum low temperature.

**Auto High** - The rear system will set to ON at maximum high temperature and fan speed, the airflow mode will be foot mode.

**Auto Low** - The rear system will set to ON at maximum low temperature and fan speed, the airflow mode will be face mode.

Any adjustment, during this time, to the rear climate controls will override these conditions. When front auto high or low is stopped the rear system will return its previous state.

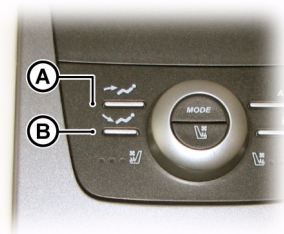

Mode	Button(s)
Face Only	A
Feet Only	B
Face and Feet	A+B

Press **A/C** if air conditioning is required.

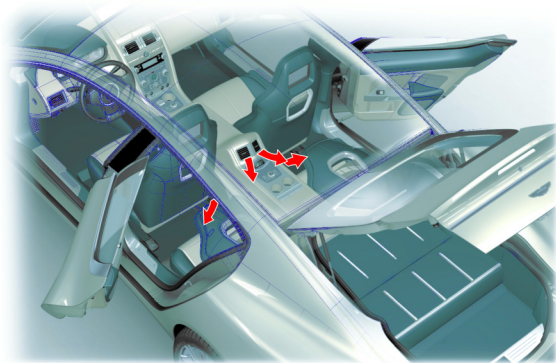

### Adjusting the Vents

To adjust the air flow vents:

 *The rear vents can not be set to OFF.*

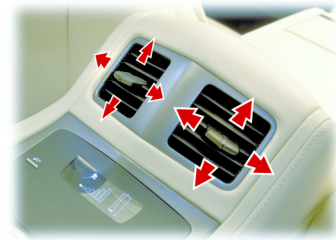

ASTON MARTIN



ASTON MARTIN



ASTON MARTIN



ASTON MARTIN



## Audio

Audio Essentials.....	7.2	Automatic Frequency Updating.....	7.10
Audio Controls.....	7.3	Regional.....	7.10
Radio Functions.....	7.6	CD Changer Functions.....	7.10
Radio Data System.....	7.8	iPod and USB Functions.....	7.13
Programme Type.....	7.9	Auxiliary Functions.....	7.15
Enhanced Other Networks.....	7.9	RSE Functions.....	7.16
		Audio Menus.....	7.18



ASTON MARTIN

**RAPIDE**

Hand built for The Frankfurt Motorshow 2009

## Audio Essentials

### Bang & Olufsen Audio

(Option)

**Radio** - AM and FM radio. 10 AM and 20 FM presets are available.

**CD** - Six CD autochanger.

**iPod<sub>1</sub>** - Connection port.

**USB Device** - Connection port.

**Auxiliary Input** - Connection port.

**Rear Entertainment System Control<sub>2</sub>** - Menu system

**Power Output** - 1000W.

### Speakers

**[1]** - Two 19 mm (soft dome) tweeters incorporating Acoustic Lens Technology (ALT).

**[2]** - Centre: Two speakers: One 101 mm mid-range in closed cabinet and one 19 mm (soft dome) tweeter.

**[3]** - Footwell: Two 152 mm woofers in closed cabinets.

**[4]** - One 101 mm mid-range speaker, in closed cabinets, in each front door.

**[5]** - One 200 mm subwoofer housed in closed cabinet in the right side boot wall.

**[6]** - Two speakers, one 90 mm mid-range and one 19 mm (soft dome) tweeter, in each rear door.

**[7]** - One 152 mm woofer in each rear door.

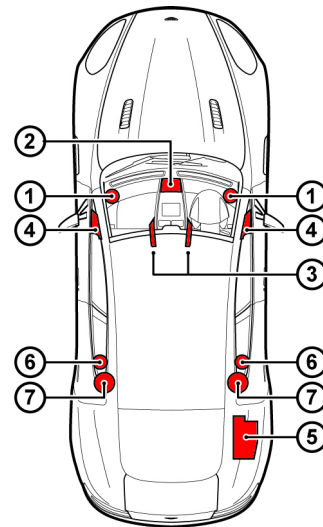

1. iPod is a trademark of Apple Inc.

2. Option

### Acoustic Lens Technology

Acoustic Lens Technology (ALT) gives a wide (180°) horizontal dispersion of high frequencies. This prevents the loss of critical sound and gives listeners an improved sense of space, staging and realism, even when not sitting in the optimal location<sup>1</sup> for listening to two-channel stereo reproductions.

Two motorised acoustic lenses, mounted on either side of the dashboard, rise when the system is set to ON and stay raised until the audio system is set to OFF.

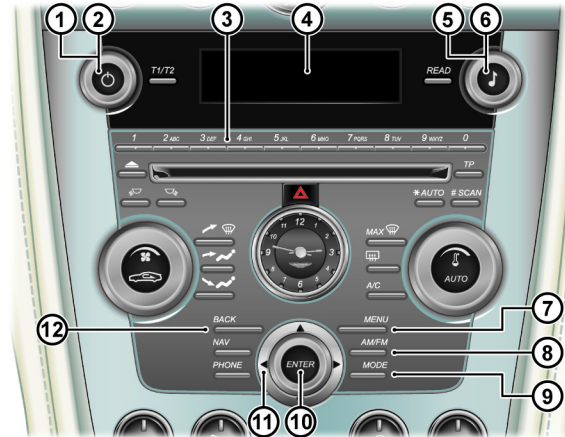

[1] **ON/OFF** - Press for audio ON and OFF.

[2] **VOLUME** - Volume control.

<sup>1</sup> For the optimal location to listen to two-channel stereo reproductions, the listener should be sitting equidistant from both loudspeakers on the apex of an equilateral triangle.

**[3] KEYPAD** - Use the numbers as menu short cuts. Press the number corresponding to the menu number.

**[4] DISPLAY** - Shows options, menus and information.

**[5] SOUND** - Press and hold to enter sound setting mode. Press repeatedly to move through settings, turn to select. When in iPod or USB mode a press and release will enable file viewing.

**[6] TUNING** - Turn to navigate through menu options.

**[7] MENU** - Opens the main menu.

**[8] AM/FM** - Press to select radio as audio source.

**[9] MODE** - Press repeatedly to select audio source.

**[10] ENTER** - Select in the menu or open a selection.

**[11] JOYSTICK** - Navigate in the menus.

**[12] BACK** - Press to move back one action. Press and hold to move back to the default screen.

**[13] VOLUME** - Volume control.

## Operation

The audio system is available with the vehicle key at least in position 'I' and is available until the vehicle key is removed from the ignition control.

If the audio system is ON when the ignition is set to OFF and the vehicle key removed, it will automatically start the next time the vehicle key is moved to position 'I'.

Press **ON/OFF** to set the audio system ON or OFF.

 *When the audio system is set to ON the volume will be at the same level it was when the audio system was set to OFF.*

The **JOYSTICK**, **ENTER** and **BACK** will not operate if Satellite Navigation is selected (**NAV** button LED ON) either press:

- The **NAV** button to deselect satellite navigation (**NAV** button LED OFF)
- Or press any audio button other than **BACK**, **ENTER** and **JOYSTICK**

to access controls for audio.

 *Pressing the **AM/FM** or **MODE** buttons will move the current audio source.*

## Sound Source

To select radio, at any time while the audio system is ON, press the **AM/FM** button repeatedly to navigate between the radio bands.

To select other audio sound sources press the **MODE** button repeatedly to navigate through the sound source choices.

## Battery Protection Mode

Using the audio system, with the vehicle key at position 'I' (ignition OFF) will drain the battery charge. A warning message will show in the message centre (right) when the battery charge is low (Refer to 'Battery Protection Mode', page 11.21).

## Menus

The audio menu is only available when the audio system is in use. Press **MENU** to access the main menu. The menu for the current audio source (i.e. radio, CD, iPod, etc.) will be available.

## Search Path

Menu paths are shown for each operation in the following format:

<FM Menu...> (Enter) <Sound settings...> (Enter)

Several menu options will require a cross in a box  to select an option. Once the menu item is highlighted press **ENTER** to either check or uncheck the box. Then press and hold **BACK** to accept and return to the main screen.

 In this chapter when asked to 'Press' a button, this means 'Press and release'. When this is not the case it will be clear in the text.

## Active Sound Control

This vehicle has a speed-dependent volume feature known as Active Sound Control (ASC). This adjusts the volume automatically depending on the speed of the vehicle.

Press **MENU** and navigate to sound source menu, press **ENTER**. Select <Auto. volume control> (Enter) <Off>, <Low>, <Optimum> or <High> (Enter).

 When in RSE mode the ASC only operates through the vehicle speakers, not through the RSE headphones.

## Original Settings

### Radio Functions

Resets all radio settings to the original factory settings: Press **MENU** and navigate to <FM Menu...> (Enter) <Advanced radio settings...> (Enter) <Reset all...> (Enter). Press **ENTER** again to confirm.

## Sound Settings

Resets all sound settings to the original factory settings: Press **MENU** and navigate to sound source menu, press **ENTER**. Select <Audio settings...> (Enter) <Reset all...> (Enter). Press **ENTER** again to confirm.

## Bang & Olufsen Audio Sound Settings

To access sound settings press and hold **SOUND** to enter sound setting mode. Then press repeatedly until the required sound setting is shown on the **DISPLAY**. Turn the **TUNING** dial to the desired setting.

### Sound Focus

(Bang & Olufsen Audio Only)

The focus of the sound from the audio system can be optimised for either the driver, the driver and front passenger, the rear passengers or all front and rear passengers. Select:

 The audio system detects seat occupancy by seat belt engagement.

**Driver** - The focus of the sound is optimised for the driver only.

**Front** - The focus of the sound is optimised for both the driver and the front passenger.

**Rear** - The focus of the sound is optimised for both rear seat passengers.

**All** - The focus of the sound is optimised both for the front and the rear passenger(s).

**Auto** - The audio system automatically detects if driver only, driver and front passenger or a rear passenger(s) are in the vehicle.

### Other Sound Settings

**Bass** - Level for bass

**Treble** - Level for treble

**Fader** - Balance between the front and rear speakers

**Balance** - Balance between the left and right speakers

**Surround** - Level for surround sound

## Radio Functions



[1] **ON/OFF** - Audio ON and OFF.

[2] **VOLUME** - Volume control.



[3] **DISPLAY** - Shows options, menus and information.

[4] **TUNING** - Turn to manually search stations or navigate in the menus.

[5] **TP** - Press to enable traffic broadcasts. Press again to disable.

[6] **SCAN** - Find and store the strongest stations.

[7] **AUTO** - Automatic station search.

[8] **MENU** - Opens the main menu.

[9] **AM/FM** - Shift between FM1, FM2 and AM.

[10] **ENTER** - Select in the menu or open a selection.

[11] **JOYSTICK** - Press left or right to auto search the next station. Press and hold left or right to manually select a station. Press up or down to navigate in the menus or preset stations.

[12] **BACK** - Press to navigate back one in the menu. Press and hold to navigate back to the default screen. Cancel a selection.

[13] **KEYPAD** - Set station presets and menu short cuts.

[14] **SCROLL** - Navigate through the preset radio stations.

[15] **VOLUME** - Volume control.

### Automatic Tuning

Select FM1, FM2 or AM using the **AM/FM** button. Press the **JOYSTICK** (left or right) to search for the next strong station.

Press left or right again to start a new search.

 *If no stations are found press either button again to cancel.*

## Manual Tuning

There are two ways to tune into a station manually.

- Turn the **TUNING** dial to set the desired frequency.
- Press and hold the **JOYSTICK** (left or right).

The frequency rolls slowly in the selected direction and increases speed after a few seconds.

Release the button when the desired frequency shows on the **DISPLAY**. If the frequency needs adjusting, briefly touch one of the arrows.

## Storing Stations

10 stations can be stored for FM1, FM2 or AM (a total of 30 stations).

To store stations:

Tune to the desired station. Press and hold the **KEYPAD** button (0-9) where the station is to be stored. The sound will be muted for a couple of seconds and 'Station Stored' will show on the **DISPLAY**.

Select a stored station by either pressing a **KEYPAD** (0 to 9) button or use the **SCROLL** button to scroll through the station list.

## Autostoring Stations

Up to ten AM or FM stations can be automatically tuned and stored in a separate memory.

Select FM1, FM2 or AM using the **AM/FM** button. Start the search by pressing and holding **AUTO** (more than two seconds).

'Autostoring.' shows on the **DISPLAY** and a number of strong stations (maximum ten) from the selected frequency band are stored in the autostore memory. If there are no stations that are sufficiently strong, 'No AST Found' shows on the **DISPLAY**.

 *If more than ten stations are found, the ten strongest are selected. This function is particularly useful if you are in an area in which you are unfamiliar with the radio stations and their frequencies.*

The stations are stored on the **KEYPAD** (buttons 0-9). When the radio is in autostore mode, 'Autostoring' is shown on the **DISPLAY**.

Return to the ordinary radio mode by pressing and releasing **AUTO** (less than 0.7 seconds). Pressing and releasing either **AUTO** or **BACK** will also cancel autostoring.

Select an Auto stored station by pressing **AUTO**, then a **KEYPAD** (0 to 9) button or the **SCROLL** button to scroll through the station list.

## Automatic Search for Transmitter

'PI seek' shows on the **DISPLAY** when reception is poor for the selected station. The radio automatically searches for the strongest transmission for that station. 'PI seek Back to cancel' is shown on the **DISPLAY** until the station is found.

## Scanning

Scanning automatically searches for the next strong FM or AM station signals. When the radio finds a station, scanning pauses for approximately eight seconds, after which it continues.

Select FM or AM with the **AM/FM** button.

Press **SCAN**. 'Scan' shows on the **DISPLAY** and each found station will play for approximately eight seconds. Press **SCAN** or **BACK** to accept the station.

 *If no stations are found press either button again to cancel.*

## Radio Data System

Radio Data System (RDS) is a system that links together specific network transmitters. It is used, for example, to tune the correct frequency of a station irrespective of the transmitter or the current audio source (e.g. CD). The system can also be used for receiving traffic information (TP) and for finding broadcasts of a specific type. Radio text is also a component of RDS. A radio station can transmit information about the radio programme currently being broadcast.

Messages with a programme code (such as news from RDS stations) will interrupt other audio sources at the volume set for this. As soon as the news broadcast is finished, the audio system returns to the previous audio source and resumes the previous volume setting.

 Some radio stations do not use RDS or only use a limited range of its features.

### Alarm

Alarms are transmitted automatically. The function cannot be set to OFF. 'Alarm!' is shown on the **DISPLAY** when an alarm message is broadcast. The function is used to warn motorists of serious accidents or disasters.

### News - ON or OFF

Press **MENU**. Navigate to <FM Menu...> (Enter) <News> (Enter). When news is ON 'NEWS' will show on the **DISPLAY**.

Press **BACK** during a news broadcast to cancel the broadcast. The news function stays ON and waits for the next news programme.

### News From Current Station

Press **MENU**. Navigate to <FM Menu...> (Enter) <Advanced Radio Settings...> (Enter) <News station...> (Enter) <News from current station> (Enter).

### TP - ON or OFF

Press **TP** repeatedly to set TP ON and OFF.

When ON 'TP' is shown on the **DISPLAY**. If the set station does not broadcast traffic information, 'TP)))' shows on the **DISPLAY**.

Press **BACK** to exit the current traffic broadcast. TP stays ON and waits for the next traffic broadcast.

### TP From a Station or All Stations

Press **MENU**. Navigate to <FM Menu...> (Enter) <Advanced radio settings...> (Enter) <TP...> (Enter) <TP station...> (Enter) <TP from current station> or <TP from all stations> (Enter).

### TP Search

This function allows you to listen to traffic information when travelling between different areas and countries without selecting a station.

Press **MENU**. Navigate to <FM Menu...> (Enter) <Advanced radio settings...> (Enter) <TP...> (Enter) <TP search> (Enter).

### Radio Text - ON or OFF

Some RDS stations broadcast information, such as about programme content and artists.

Press **MENU**. Navigate to <FM Menu...> (Enter) <Radio text> (Enter).



## Programme Type

Use the Programme Type (PTY) function to select between the various programme types.

### PTY - ON or OFF

Press **MENU**. Navigate to <FM Menu...> (Enter) <PTY...> (Enter) <Show PTY> (Enter).

When ON the station's programme type will be shown on the **DISPLAY**, e.g. Current affairs, Information, Drama, Rock music, etc.

 Not all radio stations have a PTY designation.

### Searching for a Specific PTY

Press **MENU**. Navigate to <FM Menu...> (Enter) <PTY...> (Enter) <PTY...>. Press **ENTER** for one or more of the listed programme types.

The PTY symbol on the **DISPLAY** comes ON when the first selection is made and the radio is set to stand-by for PTY.

Press **BACK** to go back.

Navigate to <FM Menu...> (Enter) <PTY...> (Enter) <Search PTY> (Enter).

If the radio finds a station with the selected programme type, this is played.

If a station with the selected programme type can not be found, the **DISPLAY** shows 'No Station Found' and the radio returns to the previous frequency.

PTY is then on stand-by until the selected programme type is broadcast. When this happens, the radio automatically selects the station broadcasting the programme type.

### Clear All PTY

Press **MENU**. Navigate to <FM Menu...> (Enter) <PTY...> (Enter) <Clear all PTY...> (Enter).

The PTY symbol is removed from the **DISPLAY** and the radio returns to normal mode.

## Enhanced Other Networks

With Enhanced Other Networks (EON) ON, traffic announcements and news broadcasts interrupt radio programmes. The function has three levels:

**Local** - Only interrupts if the signal is strong.

**Distant** - Interrupts even if the signal is weak.

**Off** - Does not interrupt even if the signal is weak.

### EON - ON or OFF

Press **MENU**. Navigate to <FM Menu...> (Enter) <Advanced radio settings...> (Enter) <EON...> (Enter). Select <Local>, <Distant> or <Off> (Enter).

When ON 'EON' is shown on the **DISPLAY**.

## Automatic Frequency Updating

The Automatic Frequency (AF) Updating function is normally ON and makes sure that the radio tunes to the strongest available transmitter.

### AF - ON or OFF

Press **MENU**. Navigate to <FM Menu...> (Enter) <Advanced radio settings...> (Enter) <AF> (Enter).

When ON 'AF' is shown on the **DISPLAY**.

## Regional

The regional function is normally OFF. When the function is ON you can continue to listen to a regional broadcasts even if the signal is weak.

Press **MENU**. Navigate to <FM Menu...> (Enter) <Advanced radio settings...> (Enter) <Regional> (Enter).

When ON 'Reg' is shown on the **DISPLAY**.

## CD Changer Functions

**[1] ON/OFF** - Audio ON and OFF.

**[2] VOLUME** - Volume control.

**[3] DISPLAY** - Shows options, menus and information.

**[4] KEYPAD** - Buttons 1- 6 to select CD and menu short cuts.

**[5] TUNING** - Turn to manually change CD tracks or navigate in the menu.

**[6] TP** - Press to enable traffic broadcasts. Press again to disable.

**[7] SCAN** - 10 seconds of each track is played. Press once again to select a track.

**[8] MENU** - Opens the main menu.

**[9] MODE** - Select CD.

**[10] ENTER** - Select in the menu or open a selection.

**[11] JOYSTICK** - Press left or right to move to the next or previous track. Press left or right and hold to search within a track or the whole CD. The search continues as long as the Joystick is pressed. Press up or down to navigate in the menus.

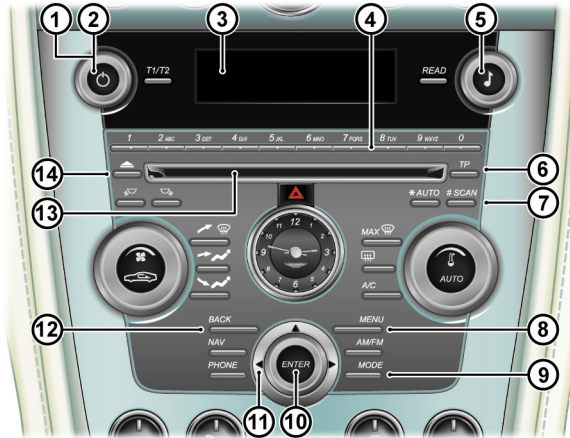

[12] **BACK** - Press to navigate back one in the menu, press and hold to navigate back to the default screen. Cancel a selection.

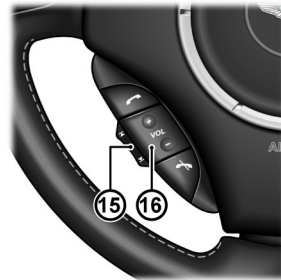

[13] - Opening for CD.

[14] **EJECT** - Eject CD.

[15] **SCROLL** - Navigate through the music tracks.

[16] **VOLUME** - Volume control.

### Loading CDs

⚠ **Use only 12 cm. CDs. Do not use CDs with adhesive disc labels. The heat from the CD player can cause the label to come loose from the disc. The CD player could be damaged.**

⚠ **Do not use CDs that are warped or look warped (critical measurement for CD warp is 0.7 mm - anything more than this may cause problems). The CD player will not be able to hold the CD correctly (because of the warp), this may cause a jam in the CD player.**

📖 **If the quality of the CD does not comply with the requirements of standard EN60908 or if it has been recorded using poor equipment, sound quality may be poor or playback interrupted.**

The CD changer can hold up to six discs.

Press the **MODE** button repeatedly to select CD. Select an empty position using the **KEYPAD** (buttons 1 to 6) or use the **JOYSTICK** (up or down). The **DISPLAY** shows which positions are empty. Make sure that 'Insert disc' is shown then insert a new disc.

## Selecting a CD

Select the CD to play using **KEYPAD** buttons 1-6 or the **JOYSTICK** (up or down). The number of the disc and track are shown on the **DISPLAY**.

## Changing Tracks

Press the **JOYSTICK** (left or right), the **SCROLL** button, or turn the **TUNING** dial to play the next or previous track. The track number is shown on the **DISPLAY**.

## Fast Forward and Rewind

Press and hold the **JOYSTICK** (left or right) to search forwards or backwards within a track or the whole disc. Searching continues for as long as the button is depressed.

## Random Play

Plays tracks from a CD or CDs in random order.

Press **MENU**> Navigate to <CD Menu...> (Enter) <Random...> (Enter). Select <Off>, <Single disc> or <All discs> (Enter) for the player to randomly choose from none, one or all CDs.

'RND' or 'RND ALL' is shown on the **DISPLAY** while the function is ON. Press the **JOYSTICK** (left or right) or **SCROLL** button to select the next or previous random track.

Press **BACK** to cancel random play.

## Scan

Press **SCAN** to play the first ten seconds of each track. While a scan is in progress press **SCAN** again or **BACK** to play a track.

## Pause Mode

When the volume is at zero, play will pause. Start play again by turning the volume up.

## Disc Text - ON or OFF

Some CDs have title information. The information is shown as text on the **DISPLAY**.

Press **MENU**. Navigate to <CD Menu...> (Enter) <Disc text> (Enter).

If information is stored on the disc, this is shown on the **DISPLAY**.

## Ejecting one CD

Press **EJECT**.

 For traffic safety reasons, the CD stays out for 12 seconds. The player will then draw back in the disc and set to pause mode. Press **CD** to start the player.

## Ejecting all CDs

Press and hold **EJECT** (for longer than two seconds). The entire magazine is emptied, CD by CD. 'Eject all' is shown on the **DISPLAY**. This function can only be used when the vehicle is stationary and is interrupted if the vehicle starts to move. For traffic safety reasons, the ejected CD stays out for 12 seconds. It must then be removed, or the function is cancelled.

## iPod and USB Functions



[1] **ON/OFF** - Press for audio ON and OFF.

[2] **VOLUME** - Volume control.

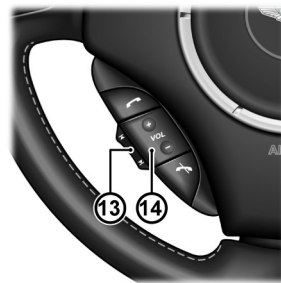

[3] **DISPLAY** - Shows options, menus and information.

[4] **KEYPAD** - Buttons 0 – 9 menu short cuts.

[5] **TUNING** - Turn to manually change tracks or navigate in the menus.

[6] **TP** - Press to enable traffic broadcasts. Press again to disable.

[7] **SCAN** - 10 seconds of each track is played. Press once again to select a track.

[8] **MENU** - Opens the main menu.

[9] **MODE** - Select USB, iPod.

[10] **ENTER** - Open the file system, select in the menu or open a selection.

[11] **JOYSTICK** - Press left or right to move to the next track or previous. Press left or right and hold to search within a track or the whole music folder. The search continues as long as the Joystick is pressed. Press up or down to navigate in the menus.

[12] **BACK** - Press to move back one action. Press and hold to move back to the default screen.

[13] **SCROLL** - Navigate through the music tracks.

[14] **VOLUME** - Volume control.

### iPod and USB Connection

The iPod port is compatible with generation three iPods onwards.

The USB port is only compatible with USB storage devices, e.g. Memory Sticks.

 On initial connection and on every engine start the system will synchronise with the connected device. This will take a short while to complete.

 The iPod controls will not operate while connected to the vehicle audio system. All functionality will be from the vehicle audio system.

Locate the iPod cable or the USB socket in the armrest cubby box and connect the:

- iPod player cable to the iPod cable
- USB device to the USB port

If not already ON, set the audio system to ON.

Repeatedly press the **MODE** button until either 'iPod' or 'USB' shows on the **DISPLAY**.

The iPod or USB device can now be operated by the audio system.

### Playing Tracks

Once the mode has been set to either iPod or USB play automatically starts.

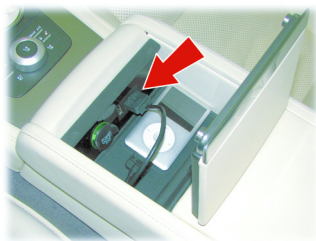

### Selecting Tracks

Press **ENTER** to show the music folder list. Using the **JOYSTICK** (up or down) or the **TUNING** dial navigate through the folder list or music tracks. Press **ENTER** to open a folder or play a track.

### Pause Mode

When the volume is at zero, play will pause. Start play by turning the volume up.

### Fast Forward and Rewind

Press and hold the **JOYSTICK** (left or right) to search within a track or the whole music folder. The search continues as long as the **JOYSTICK** is held.

### Changing Tracks

Press the **JOYSTICK** (left or right), or the **SCROLL** button, or turn the **TUNING** dial to play the next or previous track.

### Scan

Press **SCAN** to play the first ten seconds of each track. While a scan is in progress press **SCAN** again or **BACK** to play the required track.

### Random

Plays tracks from the music folder(s) in random order.

Press **MENU**. Navigate to <iPod Menu...> or <USB Menu...> (**Enter**) <Random...> (**Enter**). Select <Off>, <Folder> or <All> (**Enter**) for the player to randomly choose from none, one or all music folders. 'RND' or 'RND ALL' is shown in the **DISPLAY** while the function is ON.

Press the **JOYSTICK** (left or right) or the **SCROLL** button to select the next or previous random track.

### RDS Radio stations

News broadcasts (NEWS) and traffic information (TP) are also available when in USB or iPod mode. Refer to iPod and USB menus.

## Auxiliary Functions

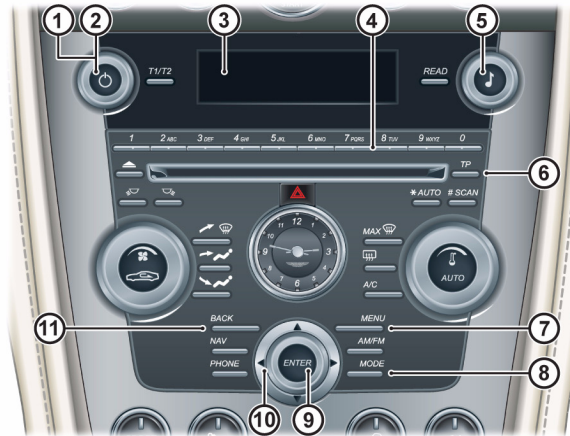

[1] **ON/OFF** - Press for audio ON and OFF.

[2] **VOLUME** - Volume control.



[3] **DISPLAY** - Shows options, menus and information.

[4] **KEYPAD** - Menu short cuts.

[5] **TUNING** - Turn to navigate in the menus.

[6] **TP** - Press to enable traffic broadcasts. Press again to disable.

[7] **MENU** - Opens the main menu.

[8] **MODE** - Select AUX.

[9] **ENTER** - Select in the menu or open a selection.

[10] **JOYSTICK** - Press to navigate in the menus.

[11] **BACK** - Press to move back one action. Press and hold to move back to the default screen.

[12] **VOLUME** - Volume control.

### Audio Device Connection

The auxiliary input socket is provided to connect audio devices which can not be connected using the iPod or USB connections.

 Only volume control will be available from the vehicle audio system. All other functionality will be from the audio device.

Locate the auxiliary socket in the front armrest cubby box.  
Connect the audio device to the auxiliary socket using a suitable cable.

If not already ON, set the audio system to ON. Repeatedly press the **MODE** button until 'AUX' shows on the **DISPLAY**.

The media device will now play through Infotainment system.

### Audio Device Volume

The vehicle audio system volume can be set at a higher or lower starting volume for the audio device.

Press **MENU** > Navigate to <AUX menu...> (Enter) <AUX input volume...> (Enter). Turn the **TUNING** dial to set the volume level.

Press and hold **BACK** to return to the main display.

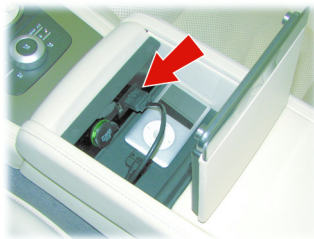

## RSE Functions

(If installed on your vehicle.)



[1] ON/OFF - Press for audio ON and OFF.



[2] **VOLUME** - Volume control.

[3] **DISPLAY** - Shows options, menus and information.

[4] **KEYPAD** - Menu short cuts.

[5] **TUNING** - Turn to navigate in the menus.

[6] **TP** - Press to enable traffic broadcasts. Press again to disable.

[7] **MENU** - Opens the main menu.

[8] **MODE** - Select AUX.

[9] **ENTER** - Select in the menu or open a selection.

[10] **JOYSTICK** - Press to navigate in the menus.

[11] **BACK** - Press to move back one action. Press and hold to move back to the default screen.

[12] **VOLUME** - Volume control.

## RSE Operation

**⚠ Warning: The driver should make adjustments only when it is safe to do so. Driver distraction can lead to accidents causing serious injury or death.**

 When the RSE menu (<Rear screen entertainment...>) is selected in the infotainment centre audio menu the RSE remote control is locked. De-select the RSE menu in the infotainment centre to use the remote control.

Supervisory control of the RSE system is from the audio menu. The RSE system, remote control and each rear screen can be set to ON or OFF using the audio menu. This lets the driver or front seat passenger select the media source and control volume level for each screen and censor DVD viewing. Each screen is set and controlled independently.

All system screen settings are adjusted using the remote control.

Press the **MODE** button repeatedly to select <RSE>. Press **MENU** and navigate to <Rear screen entertainment...>. Press **ENTER** to access the RSE menu.

The following can be set to ON or OFF:

**RSE** - Navigate to <Rear screen entertainment...> (Enter) <System on>.

**Remote Control** - Navigate to <Rear screen entertainment...> (Enter) <Remote control on>.

**Rear Screens** - Navigate to <Rear screen entertainment...> (Enter) <Right system on> or <Left system on>. Select left or right system and press **ENTER**.

**Headphone Audio** - Navigate to <Rear screen entertainment...> (Enter) <Headphones on>.

When RSE <System on> is selected the DVD screen can be set to ON or OFF. Press **MENU** and navigate to <Screen enabled> Press **ENTER** to toggle between ON and OFF. Then press and hold **BACK** to accept and return to the main screen. Press the **JOYSTICK** left or right for the right or left screen. Each screen must be set independently. When in the audio system is in RSE mode the audio playing on the left RSE system screen is heard through the vehicle speakers. Press the **JOYSTICK** right or left to select right or left screen.

 When RSE is selected the default screen is left.

## DVD Play

Press **MENU** and navigate to <Rear screen entertainment...> (Enter) <Left system > or <Right system> (Enter) <Video source> (Enter) <DVD> (Enter) <Disk selection...> (Enter) <Disk 1, 2, 3, 4, 5 or 6>.

 Only one DVD can be view at a time, on one or both screens.

## Audio

Press **MENU** and navigate to <Rear screen entertainment...> (Enter) <Left system > or <Right system> (Enter) <Audio source> (Enter). Select <Radio>, <CD player>, <Radio>, <CD player>, <SR1>, <AUX>, <SR1> or <RSE> (Enter). Repeat for the second screen if required.

When <Radio>, <CD player>, <Radio>, <CD player>, <SR1>, <AUX> or <SR1> is selected the rear passengers can listen to the vehicle audio system through the headphones. The rear passengers can not change any settings and only have control over the volume level using the headphones.

Any change to the audio source settings, for example changing tracks or radio station, must be completed through the infotainment centre. When the driver or front passenger has made changes to the audio source selected for the RSE they can return to their audio choice though the infotainment centre.

## Audio Video Devices

With <AV1> or <AV2> selected the rear passengers can listen and view media from external devices and play video games on games consoles (Refer to 'Auxiliary Connections', page 8.12).

Press **MENU** and navigate to <Rear screen entertainment...> (Enter) <Left system > or <Right system> (Enter) <Video source> (Enter) <AV1> or <AV2> (Enter). Repeat for the second screen if required.

## Audio Menus

### Radio Menu

#### 1) FM Menu...

- 1) News
- 2) PTY...
  - 1) Select PTY...
  - 2) Search PTY
    - 1) Clear all PTY...
    - 2) Select PTY station
  - 3) Show PTY (ON or OFF)
- 3) Radio text
- 4) Advanced Radio Settings...
  - 1) TP...
    - 1) TP station...
    - 2) TP search
  - 2) News station...
  - 3) AF
  - 4) Regional
  - 5) EON...
  - 6) Reset all...
- 5) Sound settings...
- 6) Auto. volume control...

#### 2) AM Menu...

- 1) Sound settings...
- 2) Auto. volume control...

---

## CD Changer Menu

### 1) CD Menu...

- 1) Play list
- 2) Random...
  - 1) Off
  - 2) Single disc
  - 3) All discs
- 3) News
- 4) Disc text
- 5) Auto. volume control...

## iPod and USB Menu

### 1) iPod Menu... or USB Menu...

- 1) Playlist...
- 2) Random...
  - 1) Off
  - 2) Folder
  - 3) All
- 3) News
- 4) Track Information
- 5) Sound settings...
- 6) Auto. volume control...

## Auxiliary Menu

### 1) AUX Menu...

- 1) AUX input volume...
- 2) News
- 3) Sound settings...
- 4) Auto. volume control...

## RSE Menu

### When the audio system in RSE mode:

- 1) Rear seat entertainment
  - 1) System on
  - 2) DVD selection...
  - 3) Right system...
  - 4) Left system...
  - 5) Remote control locked
  - 6) Disable rear screen
  - 7) Headphone audio on
- 2) RSE main audio...
  - 1) News
  - 2) Sound Settings...
- 3) Auto. volume control...
- 4) Reset all...

### When the audio system is not in RSE mode:

- 1) Audio source menu...
- 2) Rear seat entertainment...
  - 1) System on
    - 1) Right system...
    - 2) System on
  - 2) Left system...
    - 1) System on
- 3) Remote control locked

**When 'System on' is selected:**

- 1) DVD menu...
  - 1) DVD selection...
- 2) Right system...
  - 1) System on
  - 2) Screen enabled
- 3) Video source
  - 1) DVD...
  - 2) AV1
  - 3) AV2
- 4) Audio source...
  - 1) Radio
  - 2) CD player
  - 3) AUX
  - 4) iPod
- 3) Left system...



ASTON MARTIN



ASTON MARTIN

## Rear Seat Entertainment

Introduction.....	8.2
Disc Player Magazine.....	8.3
Rear Seat Entertainment.....	8.4
Supervisory Control.....	8.5
Rear Passenger Control.....	8.6
To Set the RSE ON and OFF.....	8.8
System Settings.....	8.8
RSE Media Source.....	8.9
Auxiliary Connections.....	8.12
Headphones.....	8.12
Rear Seat Entertainment.....	8.14
Troubleshooting.....	8.14



ASTON MARTIN

**RAP**

Hand built for The Frankfurt Motorshow 2009

## Introduction

The Rear Seat Entertainment (RSE) system consists of two screens (mounted in the rear of the front seat head restraints) an infotainment menu system, a six DVD or CD player, audio headphones and a remote control. The rear seat passengers can watch or listen to separate programmes or audio on each screen or use games consoles.



The player will play 12 cm DVDs, Video CDs (VCDs) and audio CDs. The player is not compatible with High Definition DVD discs, DVD-ROMs, DVD-RAMs, Photo CDs or MP3.

 *Video CDs will have less options available from their menus.*

### Safety Information

***⚠ Warning: The screen glass on the LCD display may break when hit with a hard surface. If the glass breaks, do not touch the liquid crystalline material. In case of contact with skin, wash immediately with soap and water.***

- Read all of the safety and operating instructions before operating the RSE
- Do not insert foreign objects into the disc player.
- Do not expose the LCD screen to direct sunlight or intensive ultraviolet rays for extensive periods of time. Ultraviolet rays deteriorate the liquid crystal
- Be sure to review user manuals for video games and video game equipment when used as auxiliary inputs in the RSE
- Do not operate video games or video equipment if the power cords or cables are broken, split or damaged
- Carefully place cords or cables where they will not be stepped on or interfere with the operation of seats or compartments
- Disconnect game consoles power cords or cables when not in use
- Avoid touching auxiliary input jacks with your fingers. Do not blow on them or allow them to get wet or dirty
- Do not clean any part of the disc player with benzene, paint thinner or any other solvent

### Headphones

Audio for the RSE can be delivered to the user via infra red (cordless) headphones. Volume is controlled from the headphones.

### Auxiliary and Portable Audio

Input points are supplied for audio video devices (AV1, AV2) and also portable audio devices such as iPods and music players.

### Regional Coding

Both the DVD player and DVD discs are coded by region. These regional codes must match in order for the disc to play. If the codes do not match, the disc will not play. Other regional codes cannot be played in this unit. The unit will show REGION CODE VIOLATION.

## Disc Player Magazine

**⚠ Do not leave the disc player door in the open position. If dirt or moisture enter the player this can reduce playback quality, and can result in damage to the player.**

The player is located behind the boot RH wall trim panel. To load or eject a disc:

1. Slide the player door fully open and press the **EJECT** button.
2. Remove the magazine and put in or eject a disc(s) into, with the label side facing upwards, or out of the magazine.
3. Place the magazine into the player and fully close the sliding door.

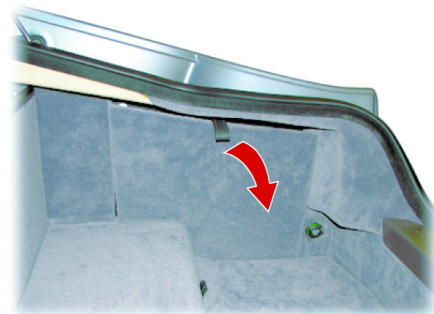

Do not place any device or object that emits a magnetic field near to the player.

Do not put in any object other than the recommended discs into the player for any reason.

Make sure that the discs are clean and dust free before inserting into the player.

 This product incorporates copyright protection technology that is protected by method claims of certain US patents and other intellectual property rights owned by Macrovision Corporation and other rights owners. Use of this copyright protection technology must be authorised by Macrovision Corporation, and is intended for home and other limited viewing uses only unless otherwise authorised by Macrovision Corporation. Reverse engineering or disassembly is prohibited.

## Federal Communication Commission (FCC) Compliance

Changes or modifications not approved by Aston Martin could void user's authority to operate the equipment. This equipment has been tested and found to comply with the limits for a Class B digital device, pursuant to Part 15 of the FCC Rules. These limits are designed to provide reasonable protection against harmful interference in a residential installation. This equipment generates, uses and can radiate radio frequency energy and, if not installed and used in accordance with the instructions, may cause harmful interference and radio communications.

However, there is no guarantee that interference will not occur in a particular installation. If this equipment does cause harmful interference to radio or television reception, which can be determined by turning the equipment off and on, the user is encouraged to consult the dealer or an experienced radio / TV technician for help.

## Rear Seat Entertainment

### Care of Disc Multi-Changer Player

#### *Environment Extremes*

Disc players which are subjected to harsh environmental conditions may be damaged or perform at less than maximum capability. To avoid these outcomes, whenever possible avoid exposing your disc player to:

- Extremely hot or cold temperatures
- Direct sunlight
- High humidity
- A dusty environment
- Locations where strong magnetic fields are generated

#### *Humidity and Moisture Condensation*

Moisture in the air will condense in the disc player under extremely humid conditions or when moving from a cold place to a warm one. Moisture condensation may cause damage to the disc or player. If moisture condensation occurs, do not insert a disc into the player. If one is already in the player, remove it. Set the disc player to ON to dry the moisture before inserting a disc. This could take an hour or more.

#### *Temperature*

When the vehicle is parked under direct sunlight or in an extremely cold place for a long period of time, wait until the cabin temperature of the vehicle is at normal temperature before operating the system.

#### *Foreign Substances*

Exercise care to prevent dirt and foreign objects from entering the disc player compartment. Be especially careful not to spill liquids of any kind onto the media controls or into the system. If liquid is accidentally spilled onto the system, immediately set the system to OFF and consult a qualified service technician.

#### *Cleaning the Display*

Clean the display screen by using a damp soft cloth. Rub the screen gently until the dust, dirt or fingerprints are removed. Do not spray the screen directly with water or glass cleaning solvents. Over spray from these fluids could drip down into the internal electronics of the screen and cause damage. Do not apply excessive pressure while cleaning the screen.

#### *Cleaning Discs*

Inspect all discs for contamination before playing. If necessary, clean discs only with an approved disc cleaner and wipe from the centre out to the edge. Do not use circular motion.



## Supervisory Control

### ***Cleaning the Disc Player***

Clean the exterior of the disc player with a damp cloth. Do not use disc cleaning kits or discs intended to clean the interior of your disc player. Use of these products may damage your system.

**⚠ *The driver should make adjustments only when it is safe to do so. Driver distraction can lead to accidents causing serious injury or death.***

Supervisory control of the RSE system is from the infotainment menu system. The RSE system, remote control, headphones and each rear screen can be set to ON or OFF using the infotainment menu system. Each screen is set and controlled independently.

When the RSE menu (<Rear screen entertainment...>) is selected in the infotainment centre audio menu the remote control is locked. The RSE menu will time-out after one minute or de-select the RSE menu in the infotainment centre to use the remote control.

All system screen settings are adjusted using the remote control.

Press the **MODE** (A) button repeatedly to select <RSE>.

Press **MENU** (B) and navigate to <Rear screen entertainment...>.

Press **ENTER** to access the RSE menu.

The following can be set to ON or OFF:



When RSE <System on> is selected the DVD screen can be set to ON or OFF. Press **MENU** and navigate to <Screen enabled>.

Press **ENTER** to toggle between ON and OFF. Then press and hold **BACK** to accept and return to the main screen.

Press the **JOYSTICK** left or right for the right or left screen. Each screen must be set independently.

**RSE** - Navigate to <Rear screen entertainment...> (Enter) <System on>.

**Remote Control** - Navigate to <Rear screen entertainment...> (Enter) <Remote control on>.

**Rear Screens** - Navigate to <Rear screen entertainment...> (Enter) <Right system on> or <Left system on>. Select left or right system and press **ENTER**.

**Headphone Audio** - Navigate to <Rear screen entertainment...> (Enter) <Headphones on>.

When in the audio system is in <RSE> mode the audio playing on the left RSE system screen is heard through the vehicle speakers. Press the **JOYSTICK** right or left to select right or left screen.

## DVD Play

Press **MENU** and navigate to <Rear screen entertainment...> (Enter) <Video source> (Enter) <DVD> (Enter) <Disk selection...> (Enter) <Disk 1, 2, 3, 4, 5 or 6>.

 Only one DVD can be view at a time, on one or both screens.

## Audio

Press **MENU** and navigate to <Rear screen entertainment...> (Enter) <Left system > or <Right system> (Enter) <Audio source> (Enter). Select the audio source. Repeat for the second screen if required.

When the audio source is selected the rear passengers can listen to the vehicle audio system through the headphones. The rear passengers can not change any settings and only have control over the volume level using the headphones.

Any change to the audio source settings, for example changing tracks or radio station, must be completed through the infotainment centre. When the driver or front passenger has made changes to the audio source selected for the RSE they can return to their audio choice though the infotainment centre.

## Auxiliary Devices

With <AV1> or <AV2> selected the rear passengers can listen and view media from external devices and play video games on games consoles (Refer to 'Auxiliary Connections', page 8.12).

Press **MENU** and navigate to <Rear screen entertainment...> (Enter) <Left system > or <Right system> (Enter) <Video source> (Enter) <AV1> or <AV2> (Enter). Repeat for the second screen if required.

## Rear Passenger Control

The rear seat passengers can operate the RSE system by using the remote control. Separate display modes and media sources for each screen can be selected using the switch on the rear of the remote control to select left and right screens. All screen settings are adjusted with the remote control.

### Remote Control

#### Front View

[1] **ON/OFF** - Press and release to for ON / OFF.

[2] **LEVEL SET** - Press to raise or lower the set level

[3]  - Press and release to pause. Press again to stop play.

[4] **DISP.** - Press repeatedly to view the setup menus.

[5] **DVD MENU** - Shows the DVD menu.

[6] **JOYSTICK** - DVD menu control. Move left, right, up, or down the menu. Press to confirm selection.

[7] **RTN** - Press to return to the previous CD or DVD menu.

[8] **VIDEO MODE** - Press to change video mode. DVD, AV1 and AV2.

[9]  - Not used.

[10]  - Not used.

[11] **MODE** - Radio, HD radio, CD, USB, RSE audio selector. Long press for AUX selection.

[12] **KEYPAD** - Press to select DVD chapters or CD tracks.

[13] **TV AUTO** - Not used.

[14] **TV** - Not used.

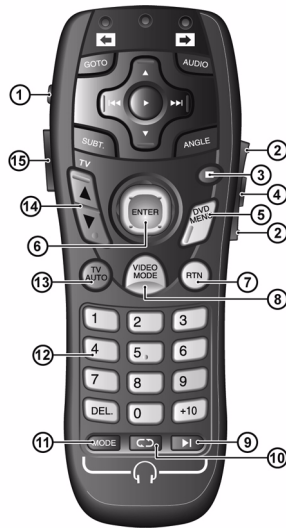

[15] **LIGHT** - Press to illuminate the controls.

[16] **GOTO** - Chapter selection and DVD status.

[17] **▲** - Next disc up.

[18] **AUDIO** - DVD audio options.

[19] **▶▶▶** - Seek forward and fast forward.

[20] **ANGLE** - DVD viewing angle options.

[21] **▼** - Next disc down.

[22] **▶** - Play and pause.

[23] **SUBT.** - DVD subtitle options.

[24] **◀◀◀** - Seek backward and fast backward.

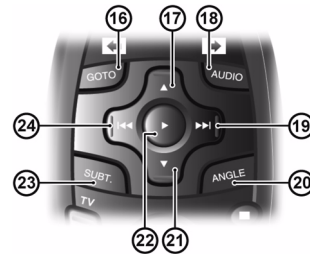

[25] **SCREEN SWITCH** - On the rear of the remote control. In the centre position the remote control is locked. Press to the left or right and press the **ON/OFF** button to set the left or right system to ON or OFF. Press down to set the screen OFF or ON.

 Only the screen is set to OFF, the audio signal continues unless another source is selected.



## To Set the RSE ON and OFF

**!** *Always operate the engine during prolonged use of the RSE system. If the engine is not operating while the RSE is in use the vehicle battery can become discharged.*

The RSE system is available with the vehicle key at least in position 'I' and is available until the vehicle key is removed from the ignition control.

The RSE system defaults to OFF on each ignition OFF.

 *If the ignition is set to OFF but set back to position 'I' within 50 seconds the RSE system will automatically start from the point it was set to OFF.*

Press **MENU** and navigate to <Rear screen entertainment...> (Enter)  
<System on> (Enter).

When the RSE system and remote control have been set to ON using the front supervisory menu, move the **SCREEN SWITCH** on the back of the remote control to the left or right (left or right screen) and press the **ON/OFF** button to set the left or right screen to ON. Move the switch to the left or right and press the **ON/OFF** button for the second screen if required.

Press the **ON/OFF** button again to set each screen to OFF as required.

 *When a screen is set to ON the last used audio or video source for that screen will play. If that source is a DVD it will resume play at the point it was left at when last set to OFF.*

- Always set the RSE system to OFF when not in use.
- Press the **EJECT** button to eject the disc, even when the RSE system is OFF.
- If the player is set to OFF before the vehicle key is removed from the ignition control, the player will return to the same point in the movie when set to ON again.

## System Settings

Use the setup screen to configure the system and adjust the picture quality.

1. Press **DISP.** to access the first setting options. Press the button repeatedly to scroll through further options.
2. When the required option is highlighted the level can be adjusted or options can be selected. Use the **LEVEL SET** buttons to adjust the set level up or down or to make a selection.
3. Press the **DISP.** button again to exit the setup menu.

The setup screen will set to OFF after two second if no buttons are pressed.

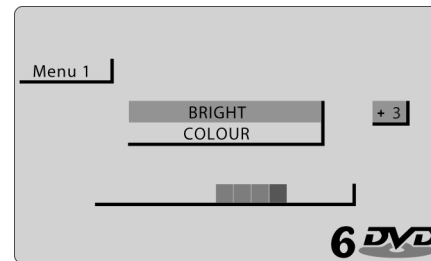

Menu options:

**BRIGHT** - Screen Brightness

**COLOUR** - Screen Colour

**DIMMER (AUTO, DAY and NIGHT)** - Day is the brightest setting. Night is the lowest setting.

**DIMMER LEVEL** - Fine tune Day and Night settings

**DISPLAY MODE** - The screen aspect ratio can be adjusted to suit the video media being viewed. Press **ENTER** to confirm your selection.

**[A] 16:9** - Wide-screen

**[B] 4:3** - Commonly used for TV

**[C] CINEMA** - Used for films produced for cinema release

**[D] ZOOM** - Slightly wider than Cinema setting

**[E] NTSC/PAL - [A] AUTO** - The system automatically selects the correct video format.

**[B] NTSC** - (National Television System Committee) Format used in North America.

**[C] PAL** - (Phase Alternating Line) Format used in other countries around the world.

**RESET TO DEFAULT** - All on screen display settings will revert to their default settings.

## RSE Media Source

 When the RSE menu (<Rear screen entertainment...>) is selected in the infotainment centre audio menu the remote control is locked. De-select the RSE menu in the infotainment centre to use the remote control.

## Disc Media Source

To select a video source press **VIDEO MODE**. Press repeatedly to scroll through the available video sources



**DVD** - Play DVDs, VCDs and CDs. Only one disc can be played at a time for one or two screens.

**AV1 or AV2** - External devices to be used by the left or right rear seat passengers.

## DVD Play

To start DVD play press and release . Press and release again to pause play (DVD still shows). Press and release again to start play.

Press and release  to pre-stop play (DVD not shown). Press and release again to end play (DVD will start from the beginning).

To seek forward and backwards by chapters press  (forwards) and  (backwards). For fast operation at x16 speed, press and hold.

To move to the next or previous disc press ▲ or ▼.

📖 *Play will start automatically when the next or previous disc is selected.*

Press and release the **DVD MENU** button to access the DVD menu. Use the **JOYSTICK** to select an option and press **ENTER** to select. Press and release **DVD MENU** again to return to the DVD.

📖 *If an attempt is made to enter a command that is either not available on the disc currently playing, or a command which is available but not at that time, a no entry symbol will appear in the top right corner of the display screen.*

📖 *The features available from the DVD menu will vary for each DVD. Refer to the instructions supplied on screen for more information.*



### DVD Special Features

Some DVD discs are recorded with additional features that allow subtitles to be displayed, camera angle to be changed and audio choices to be made. If these features are available they can be accessed using the **DVD MENU** button. The dedicated feature buttons **GOTO**, **ANGLE**, **SUBT.** and **AUDIO**, can be pressed to access the same features.

<**GOTO**> - Some DVDs offer title, chapter and time information. Press the **GOTO** button to scroll through the available options.

Use **GOTO** to access a point within the DVD programme, e.g., select chapter to show a chapter selection pop up. Using the **KEYPAD** enter a chapter number (+10 and 6 = chapter 16) then press the **ENTER** button. A long press of the **GOTO** button will show the DVD status information. A second long press will show the previous screen.

<**ANGLE**> - Some DVDs offer alternative viewing angles in selected scenes. Press the **ANGLE** button to scroll through the available options.

<**SUBT.**> - Press the **SUBT.** button to scroll through the available options. Subtitles will show along the bottom of the screen. To set subtitles to OFF apply a long press of the **SUBT.** button.

<**AUDIO**> - Some DVDs have an alternative or extra sound feature such as a commentary. Press the **AUDIO** button to scroll through the available options. The selections appear as AUDIO 1 and AUDIO 2.



### Audio Video Play

The RSE system will accept an external audio or video device. The audio or video device could be a game console, video camera, personal audio or video players, or other input device. When the external device is connected refer to the device manufactures instructions. Connect the device through the auxiliary jacks located in the rear cubby box (Refer to 'Auxiliary Connections', page 8.12).

### Audio CD Play

To start CD play press and release ►. Press and release ■ to stop play.

To select the next track press ►► and to select a previous track press ◀◀. To fast forward or backwards press and hold.

To move to the next or previous disc press ▲ or ▼.

Press and release the **DVD MENU** button to access the CD menu. Use the **JOYSTICK** to select a track and press **ENTER** to select. Press and release **DVD MENU** again to return to the CD. If there is more than one page press the **JOYSTICK** left or right. Press **RTN** to view all music folders on the CD.

When playing an audio CD, the **DISPLAY** shows the current track playing, the total playing time of the track, the total playing time of the disc and the elapsed time of the track.

### Audio Media

To select an audio source press **MODE** repeatedly to scroll through the audio sources. When the required source is shown play will commence.

Audio modes, Radio, CD, USB or AUX play media through the vehicle audio system. Control of these audio sources remains with the vehicle audio system. To select a radio station, CD AUX device function, etc. the vehicle audio system must be set to the mode the RSE system has selected. Once set the vehicle audio can return to another audio source.

## Auxiliary Connections

**⚠ Loose objects within the passenger compartment can cause death or injury in the event of an accident or sudden braking. Make sure that all auxiliary input devices are securely installed in position.**

**⚠ Auxiliary input devices can generate heat whilst operating. Do not place devices on the vehicles upholstery or carpets.**

**⚠ Ensure that any auxiliary input devices are suitable for use within a vehicle before using them.**

**⚠ Any auxiliary input devices that are used need their own power source or a suitable adapter to use power from your vehicle.**

**⚠ Power supplies, transformers, adapter leads etc. should be installed professionally to make sure of safe operation and avoid damage to the vehicle electrical system.**

**⚠ Auxiliary input devices are not intended for driver use. Do not use if they are likely to cause driver distraction.**

The RSE system will accept an audio or video input through the phono jacks located in the rear cubby box. The audio or video device could be a game console, video camera, personal audio or video players, or other input device. The auxiliary input points let separate external devices to be used by the left and right rear seat passengers, or one device can be used by both rear seat passengers.

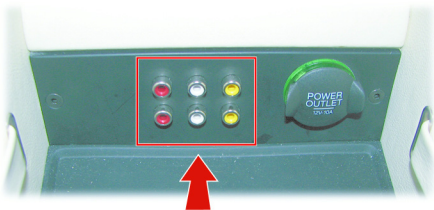

- To play an audio source connect the white lead for mono or the white and red leads for stereo.
- To play a video source connect the yellow lead.

## Headphones

**⚠ Warning: Always store headphones safely when not in use. Do not leave them unsecured as they can cause injury in the event of sudden braking or an impact.**

The RSE system includes a built-in infrared transmitter for use with wireless headphones. Adjust the volume by using the controls on each headset.

The wireless headphones must be used within a line of sight from the transmitter. See the manufacturer's instructions accompanying the wireless headphones.

Both headphones can be muted or un-muted (back to previous volume) using the infotainment centre menu system.





Using the headphones:

Press the **ON/OFF** button. The **POWER** LED will come ON.

Adjust the headphones for comfort: Hold an earpiece and pull out the headband with a smooth action. Do not use excessive force.

Select the channel to match the left or right screen. CH.1 is for the left screen and CH.2 is for the right screen.

Adjust the volume to suit.

 *The earpiece exteriors must remain exposed to the infra red transmitter in the overhead console. Any barrier will prevent them from working correctly.*

When not in use set the headphones to OFF to save battery power. The headphones will automatically set to OFF after three minutes if they have not received an infrared audio signal.

### Remote Control Battery

 **Warning: Used batteries must be disposed of correctly as they contain a number of harmful substances. Seek advice on disposal from your Aston Martin Dealer or your local authority.**

Before attempting to operate your remote control, install the batteries as shown below.

When the batteries require replacement the sound quality and volume will be compromised.

- Place the remote control face down on a level surface. Slide the battery cover off.
- Remove the old batteries if required
- Install two 'AAA' batteries as shown. Make sure that correct polarity (+ or -) is observed

- Align the cover tabs with the remote control and slide the cover on

The remote control will only operate this unit. It is not a universal remote control and will not control equipment from other manufacturers.

 *If the remote control is not used for an extended period of time, remove the batteries to prevent damage.*

## Rear Seat Entertainment

### Operating Tips

- When the engine is not operating, use the system sparingly otherwise it will drain the battery
- When the ignition is set to OFF, the RSE is also OFF
- The disc player is only capable of reading the bottom side of a disc. When inserting a single sided disc, ensure that the label is up. For a multi-sided disc, the desired play side should be down when the disc is inserted into the player
- Disc players are designed to play commercially pressed 12 cm audio compact discs only. Due to technical incompatibility, certain recordable and re-recordable compact discs may not function correctly. Irregular shaped CDs, CDs with a scratch protection film attached, and CDs with home made paper (adhesive) labels should not be inserted into the disc player. The label may peel and cause the disc to become jammed. It is recommended that home made discs be identified with permanent felt tip marker rather than adhesive labels. Ball point pens may damage discs.
- The disc player is only capable of playback of DVD-Video and DVD-VR (DVD-R / DVD-RW) discs
- Discs which are not finalised (processed to play on playback-only DVD players) cannot be played on this DVD changer

- Some discs may not play back, depending on the recording device and disc format
- Discs or files using copy protection, may not be playable. Some recording systems may not correctly format copied files to let correct playback
- In the following cases, the disc may not play on this unit: discs recorded by certain DVD recorders, certain irregular discs, flawed discs, dirty discs, when the pickup lens of this DVD player is dirty, or when moisture condensation has occurred inside the unit
- Be sure to follow all cautions included with your DVD-Rs / DVD-RWs / DVD+Rs / DVD+RWs discs
- Compared to the regular discs, DVD-Rs / DVD-RWs / DVD+Rs / DVD+RWs are more affected by heat, moisture, and direct sunlight. If left in a car, etc., damage may occur and it might not play on this unit
- The operating temperature range for disc playback is as follows: DVD-R / DVD-RW: -25 ~ +70°C. DVD+R / DVD+RW: +5 ~ +55°C

## Troubleshooting

If it appears that the RSE system is not working correctly, first consult this checklist. Do not attempt to repair the system on your own as it will invalidate the warranty.

Look for the specific symptom(s) below. Only perform the action listed to remedy the specific symptom(s).

### Remote Not Working

- Check that the batteries in the remote are OK
- Check that the remote sensor eye is not obstructed

### Disc Will Not Play

- Check that the disc is inserted with the label side facing up
- Check the type of disc you put into disc magazine
- Both the unit and the disc are coded by region. If the regional codes don't match, the disc cannot be played

### Play Starts, But Then Stops

- The disc is dirty. Clean it
- Condensation has formed. Allow the player to dry out

### No Sound or Distorted Sound

- Make sure that your unit is connected correctly. Make sure that all cables are securely inserted into the appropriate jacks

- 
- If you are using the headphones, make sure that the power to the headphones is ON
  - Make sure that the modulator is ON and the correct frequency has been selected

#### **Cannot Advance Through a Movie**

You cannot advance through the opening credits and warning information that appears at the beginning of movies because the disc is programmed to prohibit that action. The feature or action cannot be completed at this time because:

- The disc's software restricts it
- The disc's software does not support the feature (e.g., angles)
- The feature is not available at the moment
- You've requested a title or chapter number that is out of range

#### **Picture is Distorted**

- The disc might be damaged. Try another disc
- It is normal for some distortion to appear during forward or reverse scan



ASTON MARTIN



ASTON MARTIN



ASTON MARTIN



ASTON MARTIN



ASTON MARTIN

# Hands-Free Phone

Introduction.....	9.2
Hands-Free Functions .....	9.2
Connecting a Phone.....	9.4
Disconnecting a Phone .....	9.5
Pairing Phones .....	9.5
Selecting a Phone.....	9.7
Using a Phone.....	9.7
Phone Book.....	9.8
Voice Mailbox.....	9.9
Last Ten Numbers.....	9.9
Hands-Free Menu.....	9.9



ASTON MARTIN

**RAPIDE**

Hand built for The Frankfurt Motorshow 2009

## Introduction

A mobile device equipped with hands-free (bluetooth) capability can be connected wirelessly to the vehicle's hands-free phone system. The vehicle's hands-free phone system then provides remote control of a range of the mobile phone's functions. The mobile phone can always be operated by its own keys regardless of whether or not it is connected.

The hands-free system is available when the vehicle key is in ignition position 'I' or 'II'. If, during a call, the vehicle key is moved to position '0' or removed the call will transfer to the mobile phone after approximately six seconds.

The system microphone is located in the vehicle roof above the drivers head (A) and the speech from an incoming call is from the two door speakers (B).

 The hands-free phone system will not recognise a mobile phone, even if it is 'paired', if the mobile phone does not have bluetooth enabled. For more information refer to the user guide for your mobile phone (Refer to page 9.4).

 The hands-free phone system does not support SMS (text messages).

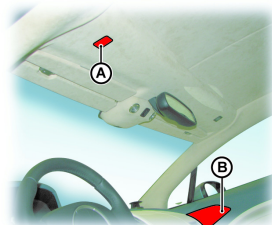

## Hands-Free Functions



[1] **VOLUME** - Volume control.

[2] **DISPLAY** - Shows options, menus and information.

[3] **TUNING** - Navigate through phone book and menus.

[4] **MENU** - Opens the main menu.

[5] **ENTER** - Press to answer or make a call, select in the menu or open a selection.

[6] **JOYSTICK** - Navigate in the menus, move forwards or backwards when entering text and digits.

[7] **PHONE** - Press to select hands-free mode or press and hold to cancel hands-free mode.

[8] **BACK** - End a call, navigate back in the menu, cancel a selection or erase the previous character when entering text and numbers.

[9] **KEYPAD** - Search through the phone book, speed dial or navigate in the menu.

[10] **CALL** - Press to answer a call or press to return to hands-free mode from audio when hands-free mode is ON.

[11] **VOLUME** - Volume control during a call.

[12] **SCROLL** - Navigate in the menus.

[13] **CANCEL** - Press to end a call or press to enter audio mode when hands-free mode is selected./P

## Hands-Free Phone ON

When the hands-free system is ON the  symbol will show in

the **DISPLAY**. During a call this symbol will change to . When

a mobile phone is connected to the hands-free system the  symbol will show in the **DISPLAY**. If, after 30 seconds, the hands-free phone has not been used, the infotainment system will default to audio functions. Return to hands-free phone functions by pressing **PHONE** or **CALL**.

### Menus

The hands-free menu is available when the hands-free phone system is ON and selected. If not ON or not selected press **PHONE**. Press **MENU** to access the main menu.

### Search Path

Menu paths are shown for each operation in the following format:  
<Phone menu...> (Enter) <Phone settings...> (Enter) <Sounds and volume...>

 In this chapter when asked to 'Press' a button, this means 'Press and release'. When this is not the case it will be clear in the text.

Several menu options will require a cross in a box  to select an option. Once the menu item is highlighted press **ENTER** to either check or uncheck the box. Then press and hold **BACK** to accept and return to the main screen.

### Call Menu

Press **MENU**, **ENTER** or **CALL** during an ongoing call to access the following functions:

**Mute microphone** - The hands-free system microphone is muted.

**Transfer call to mobile or Transfer call to vehicle** - The call can be transferred to or from the mobile phone or the vehicle phone.

**Phone book** - Access the phone book during a call.

 Some mobile phones will close the connection when the privacy function is used, this is normal. The vehicle system asks if you want to reconnect.

## Audio Settings

### Call Volume

During a call the call volume can be regulated using the **VOLUME** dial or button.

### Audio System Volume

The audio source can be automatically muted for incoming calls:

Press **MENU** and navigate to <Phone menu...> (Enter) <Phone settings...> (Enter) <Sounds and volume...> (Enter) <Mute radio> (Enter).

If mute radio is OFF select one of the audio sources to control the audio system volume during an ongoing call.

### Audio System Control

Not available during a call.

When the audio system is in operation while hands-free mode is ON press **CALL** to return to hands-free mode.

### Ring Volume

Press **MENU** and navigate to <Phone menu...> (Enter) <Phone settings...> (Enter) <Sounds and volume...> (Enter) <Ring volume> (Enter). Adjust using the **TUNING** dial.

## Ring Signals

The vehicle system has integrated ring signals that can be selected:

Press **MENU** and navigate to <Phone menu...> (Enter) <Phone settings...> (Enter) <Sounds and volume...> (Enter) <Ring signal> (Enter) <Select Ring signal 1, 2, 3 etc.> (Enter).

 *The connected mobile phone's ring signal is not muted when one of the vehicles integrated signals is used.*

## Connecting a Phone

A connection between the vehicle hands-free system and a mobile phone is called a 'Paired Link'. When a paired link is set up the hands-free system remembers the mobile phone's ID.

Once the hands-free system and the mobile phone are paired, the hands-free system automatically connects every time the ignition is set to ON if the hands-free system (Press **PHONE**) and the mobile phone are ON.

A mobile phone can be paired either using the vehicle hands-free system or by using the mobile phone.

This system supports paired links with up to five phones.

 *The process of initiating a hands-free connection with a phone varies per phone manufacturer. For more information refer to the user's guide for your mobile phone.*



## Disconnecting a Phone

The mobile phone will **automatically** disconnect when moved out of the Hand-Free system's range or bluetooth is made unavailable on the mobile phone.

The mobile phone will **manually** disconnect when the hands-free system is set to OFF. Press and hold **PHONE** until  is removed from the **DISPLAY**. The function is also stopped when the ignition is set to OFF.

If the mobile phone has been disconnected from the hand-free system during an ongoing call, the call will transfer to the mobile phone.

 Some mobile phones require that the transfer is confirmed from the phone's keypad.



## Pairing Phones

### Initial Pairing

Use this procedure when pairing the first mobile phone to the hands-free system. If the hands-free system is not ON or in use, press **PHONE**.

The **DISPLAY** will show NO PAIRED PHONES. PRESS ENTER AND SELECT ADD A PHONE. Press **EXIT** to cancel. Press **ENTER**.

The hands-free system will asked if bluetooth is in discoverable mode (refer to the mobile phone manufactures instructions). If yes press **ENTER**. After a short while a list of phones which are in range and in discoverable mode will be shown.

 If the  symbol is shown in the **DISPLAY** when the ignition is ON, initial pairing can be completed using the mobile phone.

Press the **JOYSTICK** (up or down), **SCROLL** button or turn the **TUNING** dial to navigate to the required mobile phone and press **ENTER**. The **DISPLAY** will then ask for a passkey to be entered into the mobile phone. The mobile phone will prompt for the passkey. Enter the passkey into the mobile phone.

The **DISPLAY** will show PHONE CONNECTING... then, if successful, SYNCHRONISING.

Once synchronising has completed the mobile phone is ready for use.

 If the passkey is not entered after 20 seconds the screen will time-out.

 Synchronising automatically places all the mobile phone contacts onto the vehicle system.

### Pairing Additional Phones

#### Pairing Using the Hands-Free System

 Disconnect any in use phones before pairing additional phones. If a phone is connected to the hands-free system pairing a new phone will not be possible until the hands-free system has no in use bluetooth connections.

 If, after 30 seconds, the hands-free phone has not been used, the infotainment system will default to audio functions. Return to hands-free phone functions by pressing **PHONE** or **CALL**.

Check that the mobile phone has bluetooth ON and visible. Check that the hands-free system is ON ( symbol will show in the **DISPLAY**).

The hands-free system automatically searches for the last used phone. If the last used phone is not found a list of paired phones will show along with <Add phone>. Select <Add phone> to pair a new phone to the system.

If the last used phone is found press **MENU** and navigate to <Phone Menu...> (Enter) <Bluetooth...> (Enter) <Change phone...> (Enter) <Add Phone...>.

Press **ENTER**. The hands-free system will be asked if bluetooth is in discoverable mode (refer to the mobile phone manufacturer's instructions). If yes press **ENTER**. After a short while a list of phones which are in range and in discoverable mode will show.

Press the **JOYSTICK** (up or down), **SCROLL** button or turn the **TUNING** dial to navigate to the required mobile phone and press **ENTER**.

The **DISPLAY** will then ask for a passkey to be entered into the mobile phone. The mobile phone will prompt for the passkey. Enter the passkey into the mobile phone.

The **DISPLAY** will show PHONE CONNECTING... then, if successful, SYNCHRONISING. Once synchronising has completed the mobile phone is ready for use.

 If the passkey is not entered after 20 seconds the screen will time-out.

 Synchronising automatically places all the mobile phone contacts onto the hands-free system.

### Pairing Using the Mobile Phone

 Disconnect any in use phones before pairing additional phones. If a phone is connected to the hands-free system pairing a new phone will not be possible until the hands-free system has no in use bluetooth connections.

Check that the hands-free system is selected ( symbol will show in the **DISPLAY**).

Follow the mobile phone manufacturer's instructions to search and connect to a new bluetooth device. The phone will search for discoverable bluetooth devices in its range.

Select ASTON MARTIN from the device list. The phone will prompt for a passkey.

 If ASTON MARTIN does not show check that the hands-free system is selected and search again.

Press **MENU** (on the vehicle) and move to <Phone menu...> (Enter) <Bluetooth...> (Enter) <Connect from Mobile Phone> (Enter). The **DISPLAY** will then show a passkey, enter the passkey into the mobile phone.

The **DISPLAY** will show PHONE CONNECTING... then, if successful, SYNCHRONISING. Once synchronising has completed the mobile phone is ready for use.

 If the passkey is not entered after 20 seconds the screen will time-out.

 Synchronising automatically places all the mobile phone contacts onto the vehicle system.

### Removing a Paired Phone

#### Using the hands-free system

Press **MENU**. Navigate to <Phone menu...> (Enter) <Bluetooth...> (Enter) <Remove Phone> (Enter).

A list of paired phones will show. Navigate to the required phone and press **ENTER** to erase or **BACK** to cancel.

## Selecting a Phone

 *The phone to be selected must have bluetooth ON, visible and in close proximity to the hands-free phone system.*

A phone can be selected by using the phone itself or by using the hands-free system:

### Using the Mobile Phone

If not ON or not selected, press **PHONE**.

Using the Mobile phone, follow the manufactures instructions to search and connect to a bluetooth device. The phone will search for discoverable bluetooth devices in its range. Select ASTON MARTIN from the device list. Select Connect.

 *If ASTON MARTIN does not show check that the hands-free system is selected and search again. If ASTON MARTIN still does not show the mobile phone may not be paired (Refer to 'Pairing Phones', page 9.5)*

### Using the Vehicle hands-free system

With the hands-free system already selected, press **MENU** and navigate to <Phone Menu...> (Enter) <Bluetooth...> (Enter) <Change Phone> (Enter). A list of paired phones will show (along with Add phone). Navigate to the required phone and press **ENTER** to change or **BACK** to cancel.

Or, if the hands-free system is not ON:

Press **PHONE**. The system will then scan for the last used mobile phone. If found and it is the mobile required then press **ENTER**. If the last phone is not found the **DISPLAY** will show a list of paired phones within range (with bluetooth ON). Navigate to a phone and press **ENTER** to select that phone.

## Using a Phone

### Making a Call

Check that the hands-free system is selected ( symbol shows in the **DISPLAY**).

Press **PHONE**, or **CALL** on the steering wheel controls.

- Press the **JOYSTICK** (up or down), **SCROLL** button, or turn the **TUNING** dial to select a contact from the phone book. Press **CALL** or **ENTER** to call.

Or

- Dial the number using the keypad and press **CALL** or **ENTER** to call. Press **BACK** to erase a number. Press and hold **BACK** to erase the whole number.

### Ending Calls

To end a call press **CANCEL** or **BACK**.

### Reject a Call

Press **CANCEL** or **BACK** while the phone is ringing.

### Calling Using Voice Recognition

If the mobile phone supports voice dialling:

Press, hold and release **CALL** or **ENTER**. The amount of time required to hold in **CALL** or **ENTER** is dependant on the mobile phone.

Once 'Voice Tag Dialling' shows on the **DISPLAY**, allow one to two seconds before saying a name. The vehicle system will call the contact.

### Receiving Calls

To answer an incoming call press **CALL** or **ENTER**.

### Automatic Answer - ON or OFF

The automatic answer function means that calls are accepted automatically after four rings.

Press **MENU** and navigate to <Phone menu...> (Enter) <Phone settings...> (Enter) <Call options...> (Enter) <Automatic answer> (Enter).

## Phone Book

The mobile phone's phone book is synchronised automatically to the vehicle system at each connection.

If it is not required to synchronise to phone book:

Press **MENU** and navigate to <Phone menu...> (Enter) <Phone settings...> (Enter) <Synchronising phone book> (Enter).

If the phone book contains a caller's contact information, this is shown in the **DISPLAY**.

 If the mobile phone does not support copying of the phone book, 'List is empty' is shown when copying is finished.

### Contact Search

Searching for contacts is only performed in the connected mobile phone's phone book. Either:

Press the **JOYSTICK** (up or down), **SCROLL** button, or turn the **TUNING** dial to bring up the contact list. Navigate to the contact. Press **CALL** or **ENTER** to call.

Or

Use the **KEYPAD** to search the phone book. Press and hold a key (2 to 9) which relates to the first letter of the contact's name. This starts a search in the phone book based on the key's first letter. Navigate to the contact. Press **CALL** or **ENTER** to call.

Or

Press **PHONE**. Press **MENU** and navigate to <Phone menu...> (Enter) <Phone book...> (Enter) <Search> (Enter). Using the **KEYPAD**, enter the first few letters of the contact name, press **ENTER**.

Navigate to a contact. Press **CALL** or **ENTER** to call.

## Voice Mailbox

To enter a voice mailbox number:

Press **MENU** and navigate to <Phone menu...> (Enter) <Phone settings...> (Enter) <Call options...> (Enter) <Voice mail number> (Enter) <Enter the number> (Enter)

Or

Press and hold **KEYPAD** number 1 to go to <Voice mail number>. Enter the number and press **ENTER**.

Use the stored number by pressing 1 for several seconds.

To change the voice mail number go to *Voice mail number*. Press and hold **BACK** to erase the whole number or press and release to erase individual numbers. Once the number has been erased then enter a new number.

 *If the mobile phone has the voice mail number already stored then this will be placed into the system when synchronising during pairing.*

## Last Ten Numbers

### Last Ten Dialed Numbers

Press **ENTER**. Use the **JOYSTICK** (up or down), **SCROLL** button, or turn the **TUNING** dial to navigate to the required number. Press **CALL** or **ENTER** to call that number.

### Last Ten Missed and Received Numbers

Press **MENU** and navigate to <Phone menu...> (Enter) <Last 10 missed calls> or <Last 10 received calls> (Enter).

Use the **JOYSTICK** (up or down), **SCROLL** button, or turn the **TUNING** dial to navigate to the required number. Press **CALL** or **ENTER** to call that number.

 *Last ten dialed will also be available.*

## Hands-Free Menu

### 1) Phone Menu...

- 1) Last 10 missed calls
- 2) Last 10 received calls
- 3) Last 10 dialed calls
- 1) Phone book...
  - 1) Search
  - 2) Copy fr. mobile phone
- 2) Bluetooth...
  - 1) Change Phone...
  - 2) Remove Phone
  - 3) Connect from mobile phone
- 3) Phone settings...
  - 1) Call options...
    - 1) Automatic answer
    - 2) Voice mail number
  - 2) Sounds and volume...
    - 1) Ring volume
    - 2) Ring signals...
    - 3) Mute Radio
  - 3) Synchronising phone book



ASTON MARTIN



ASTON MARTIN



ASTON MARTIN

# Satellite Navigation

Introduction .....	10.2	Avoid Specific Areas.....	10.18
System Controls .....	10.3	Information.....	10.20
Easy Mode Settings.....	10.6	Current Position.....	10.20
Using Easy Mode.....	10.7	Quick Menus.....	10.20
Advanced Mode Settings.....	10.9	Maps .....	10.21
Using Advanced Mode.....	10.12	Traffic Information .....	10.25
Store a Destination.....	10.16	Traffic Surveillance.....	10.28
Itinerary .....	10.17	Frequently Asked Questions.....	10.28

## Introduction

The satellite navigation system is an integrated part of the infotainment system along with the audio system.

This navigation system has been developed to help guide you to the destination of your choice. The system includes features that lets you to set itineraries, search for certain types of points of interest along your route, store special destinations, etc.

The navigation system can be used without a destination being selected. The map with the position of your vehicle is shown on the **SCREEN** and your vehicle is shown with a blue triangle.

**⚠ Warning: Never use the navigation system or any other feature in the vehicle in a way that distracts you from the task of driving safely.**

**⚠ Warning: Distraction can lead to a serious accident. Set and make changes in the navigation system only with the vehicle parked.**

**⚠ Warning: Be aware of the current traffic situation.**

**⚠ Always use good judgment when following navigation system guidance, and do not follow guidance that seems contrary to your own best judgment. Never use the navigation system or any other feature in your vehicle in a way that distracts you from the task of driving safely. Distraction can lead to a serious accident. Set and make changes in your navigation system only with the vehicle parked. Be aware of the current traffic situation. Always comply with relevant traffic regulations.**

Two modes of operation are available:

**Easy Mode** - Provides simple functionality to enable the user to select a destination.

**Advanced Mode** - Provides all system functionality.

The navigation system has all maps and features, for the market area, installed in the vehicle's electronic memory.

A DVD player is provided to install map and feature up-dates as and when available.

The locations used in this chapter do not necessarily reflect known places and are for the purpose of describing operating procedures only.

## Global Positioning System

The vehicle's speed sensor and a gyro calculate the current position and the direction of travel of the vehicle using signals from the Global Positioning System (GPS) satellite system.

## Traffic Message Channel Receiver

Standardised code system for traffic information. The Traffic Message Channel (TMC) receiver seeks the relevant frequency. Transmission occurs via FM frequencies<sup>1</sup>. The system is currently being expanded.

## Screen Care

The **SCREEN** must only be cleaned with a soft, lint free, dampened cloth, or a cloth with a mild window cleaning agent.

## Map Updates

Factors such as the constant expansion and rebuilding of the road network, new traffic regulations constantly being introduced etc. means that the digital map database is not always up-to-date. Digital maps are continuously updated and the coverage is increased gradually.

---

<sup>1</sup>. Transmission is not available everywhere.



## System Controls

Map updates are available on DVD. For information on the latest versions and installation of map DVDs, contact your Aston Martin Dealer.

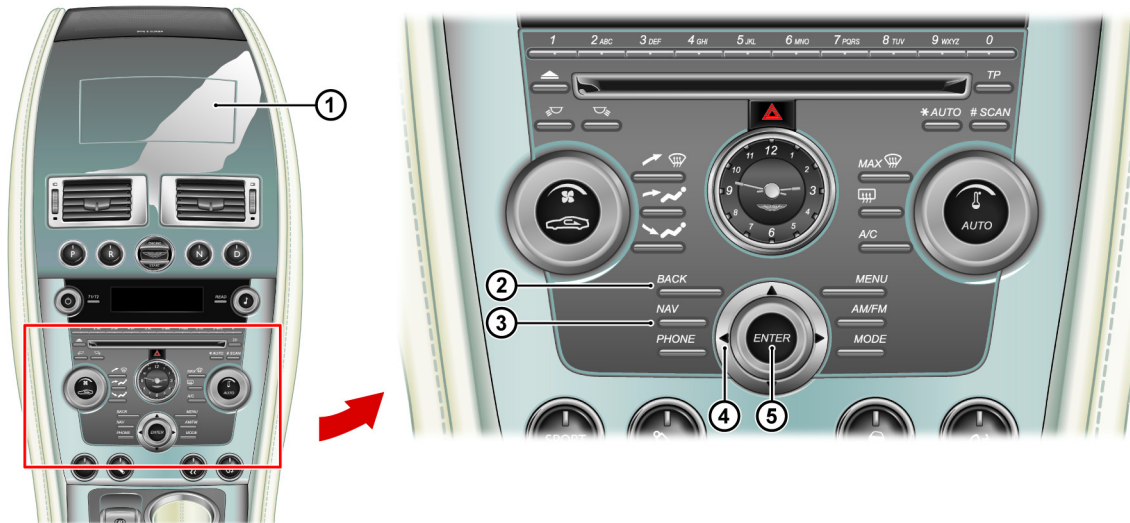

**[1] SCREEN** - Shows maps and provides detailed information on route type, distance, etc.

**[2] BACK** - Press to return to the previous menu or to undo a choice.

**[3] NAV** - Press to enable or disable Satellite navigation controls.

**[4] JOYSTICK** - Navigate through different menu options, traffic messages, etc.

**[5] ENTER** - Press to confirm, select or navigate from one submenu to the next submenu.

## Navigation System ON and OFF

### To Set the Navigation System ON

The vehicle key must be at position 'I' or 'II' in the ignition control.

1. Press the **NAV** button (button LED ON).
2. Press **ENTER**. The navigation screen will open. On start up the **SCREEN** will show the option of running the navigation system in easy or advanced mode.

Select <Easy> or <Advanced> using the **JOYSTICK** and press **ENTER**. The user mode can be changed at any time in the system setup menu.

The **SCREEN** defaults to map view.

 The system may need a few seconds to detect your position and movement.

While the **NAV** button LED is ON the **BACK**, **ENTER** and **JOYSTICK** functions only operate the navigation system.

To use the **BACK**, **ENTER** and **JOYSTICK** functions for audio or hands-free phone functions either:

- Press the **NAV** button again (button LED OFF).
- or
- Press any audio button other than **BACK**, **ENTER** and **JOYSTICK**.

Press **NAV** (button LED ON) again to return to navigation controls.

 Pressing the **AM/FM** or **MODE** buttons will move the current audio source.

### To Set the Navigation System OFF

 If in map mode press the **BACK** to view the main menu.

From the main menu move to <Shutdown> and press **ENTER**. The navigation screen will close after a few seconds.

Press the **NAV** button (button LED OFF) or press any audio button other than **BACK**, **ENTER** and **JOYSTICK** to return functions back to audio.

 The navigation system can be accessed even if the ignition is OFF. Always set the vehicle key to position '0' in the ignition control or remove the vehicle key when the system is not in use so the battery does not become discharged.

 If the navigation system is ON when the vehicle key is removed the system will shut down. When the vehicle key is inserted again and placed at position 'I' or 'II' the navigation system will start up automatically. Press the **NAV** button to select navigation controls.

## Main Menu

The main screen provides access to system functions. While in the default screen (map view) press **BACK**. Using the **JOYSTICK** select a menu option and then move right or press **ENTER** to access the functions.

The navigation menu is only available when the **NAV** button LED is ON.

 When asked to 'Press' a button, this means 'Press and release'. When this is not the case it will be clear in the text.



### Easy Menu

Set destination  
 Show destination<sup>1</sup>  
 Remove destination<sup>1</sup>  
 Settings  
 Shut down

### Advanced Menu

Set destination  
 Itinerary<sup>1</sup>  
 Next destination<sup>1</sup>  
 Current position  
 Settings  
 Shut down

<sup>1</sup>. Available when a destination is entered.

### Search path

Menu paths are shown for each operation in the following format:

<**Set destination**>(Enter)<**Address**>(Enter)

Menu selections in the text are shown by <All Cities>.

### Quick Menus



Press **ENTER** while in map view to access the quick menus. Select a quick menu using the **JOYSTICK**. Select an option and press **ENTER**. (Refer to 'Quick Menus', page 10.20).

Quick menus make it easier to access certain system options.

Some options are only accessible through the quick menus.

### Guidance Voice

**With Audio ON** - If guidance voice is ON, when guidance is provided the audio system will mute until the guidance message has finished.

**Phone in Use** - If guidance voice is ON, guidance messages will be muted if the hands-free phone system is in use.

If a guidance message is broadcast during a phone call an audible 'Beep' will be heard.

### Demo (Guidance Simulation)

#### Advanced Mode Only

<**Settings**>(Enter)<**Start demo**>(Enter)

The demo shows how the system works when the vehicle is stationary by simulating a trip to a specified destination. All settings can be made during the demonstration. Select <Stop demo> to stop the simulation.

A destination must be entered for the demo to work.

### Screen Display

The screen display is determined by factors such as geographic location and settings that have been made, such as map scale, the symbols selected to be shown, etc.

**[1] ON A MOTORWAY** - The screen will show the facilities along the motorway. This function is available even if a destination has not been selected. A scroll list at the right shows that there are additional alternatives.

**[2] DETAILED MAP SHOWING JUNCTIONS** - The screen will show lanes on the road to help you select the correct one at the next junction. This function is only available on major roads. Voice guidance is also always provided.

**[3] TWO MAPS HAVE BEEN SELECTED IN SETTINGS** - Both sections of the screen show the same map, but with different scales (Refer to 'Maps', page 10.21).

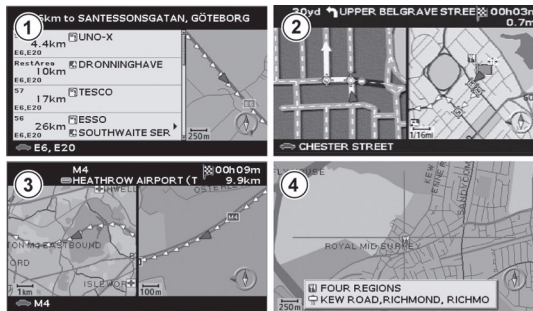

**[4] MAP SCROLL MODE** - (Refer to 'Maps', page 10.21).

### Unverified Roads

A small number of roads in the system may be unverified. This means that information on signs, one-way streets, left turns, etc., may not be accurate. An itinerary containing unverified roads will be shown with gray arrows instead of the usual yellow ones. The system provides information when an unverified road is added to an itinerary and when the vehicle begins to travel on one of these roads.

### Compass

The red tip of the compass needle points in a northerly direction on the map. The destination arrow in the outer ring of the compass points in the direction of the destination. Under *<Map options>* on the Settings menu you can choose to show or hide the compass and destination arrow.



## Easy Mode Settings

### System Settings

*<Settings>* (Enter)

Use the **JOYSTICK** to move between the functions and select the desired setting. Confirm settings made using **ENTER**.

*<Guiding voice>* - A male or a female guiding voice can be selected.

*<Guiding volume>* - Guiding voice volume.

*<Language>* - Select the language to be used.

*<Colour>* - Select *<Black>*, *<Blue>*, *<Dark>* or *<Chrome>*.

*<Map view>* - Select to view either a 2D or 3D map.

*<Distance unit>* - Select *<Miles>* or *<km>*.

*<User mode>* - Select *<Easy>* or *<Advanced>*. All destinations will be erased if changing operating modes.

## Using Easy Mode

The navigation system requires a destination to be entered so that a route to the destination can then be calculated. In easy mode only one destination can be entered at a time.

 If the **SCREEN** is in map view press **BACK** to access the main menu.

### Destination by an Address

<Set Destination>(Enter)<Address>(Enter)

The last selected country and city will be remembered. If searching for a destination outside the current country move to <Country> and press **ENTER**.



Use the **JOYSTICK** to spell out the desired country from the character table. Press **ENTER** for each letter.

 When there are no more alternatives, the system fills in the missing letters itself.

A list of countries matching that letter combination is shown at the bottom of the **SCREEN**. A scroll bar on the right shows that there are several alternatives in the list. The number shows how many.

Using the **JOYSTICK** move down and select directly from the list in the menu. Select and press **ENTER**.

While scrolling through the list, return to the character table by pressing **BACK**. Press **BACK** to erase the entered letters one at a time.

### Select City

Move to <City> and press **ENTER**.

Use the **JOYSTICK** to spell out the desired city from the character table. Press **ENTER** for each letter.

 When there are no more alternatives, the system fills in the missing letters itself.

A list of cities matching that letter combination is shown at the bottom of the **SCREEN**. A scroll bar on the right shows that there are several alternatives in the list. The number shows how many.

Using the **JOYSTICK** move down and select directly from the list in the menu. Select and press **ENTER**.

While scrolling through the list, return to the character table by pressing **BACK**. Press **BACK** to erase the entered letters one at a time.

 The definition of city or area may vary from country to country or even within a country. Sometimes it refers to a municipality, while other times it refers to an individual section of a city.

### Select Street

Move to <Street> and press **ENTER**. Select as described for select city.

 It is also possible to search for street addresses throughout a country without specifying a particular city.

 Street addresses are not stored in the system for some small towns. The town centre, however, can always be specified as the destination.

Once a street has been selected it is then possible to move to <Start Guide>.

When *<Start guide>* is selected, the system begins calculating the route and distance to the destination (during this time, a yellow symbol is shown at the top of the **SCREEN**). If a detour is made from the planned route during the trip, the system automatically calculates a new route.

 *If neither a street number or an intersecting street is specified the system guides to the middle of the street chosen.*

### Select Street Number or Junction

If the street number of the selected address is known, it can also be entered to make guidance more exact. An intersecting street (junction) can also be entered instead of the street number.

Move to *<Number>* and press **ENTER**. Existing street numbers are then shown. Select a number using the **JOYSTICK** (right or left) and press **ENTER**.

Once a valid number has been entered move to:

**<Set>** - Confirm entered number.

**<Cancel>** - Go back to the previous screen.

Move to *<Junction>* and press **ENTER**.

The roads that intersect the selected street are shown in a list. Select from among the streets and press **ENTER**.

### Destination by a Post Code

Using the **JOYSTICK** move to *<City>* and press **ENTER**. Move to *<Post code>* and press **ENTER**.

Use the **JOYSTICK** to select the desired letters and numbers from the character table and press **ENTER**. Move down and select a post code from the list. Press **ENTER**.

While scrolling through the list, press **BACK** to return to the table of characters. Press **BACK** to erase entered characters.

 *In some countries the entire post code cannot be specified.*

Move to *<Street>* and press **ENTER**. Choose letters using the **JOYSTICK** and press **ENTER** or move down and choose a street name directly from the list if options are available.

Then move to *<Number>* or *<Junction>* to specify a street number or a crossroads. Select *<Start Guide>* to obtain guidance to the destination.

### Destination by a Facility

**<Set destination>**(Enter)**<Facilities>**(Enter)

Facilities is a collective name for places such as petrol stations, hotels, restaurants, Aston Martin Dealers, hospitals, vehicle parking, etc.

Select *<City>* and press **ENTER**. Select a city as described earlier.

 *When a city is entered facilities are searched for around the city area. If you want to search for a facility by *<Name>* or *<Type>* without specifying a city, select *<City>*, press **ENTER**, then **BACK** to erase the current city.*

It is possible to first select *<Type>* then *<Name>* without entering a city.

Move to *<Type>* or *<Name>* and press **ENTER**.

Use the **JOYSTICK** to select the desired letters and press **ENTER** or move down and select directly from the list in the menu. Select and press **ENTER**.

Some facilities (when selecting by *<Type>*) have further options. For example, select petrol station and press **ENTER**.

The names of different petrol chains found in that area are then shown. Select from among the alternatives and press **ENTER**. Return to the character table with **BACK**. Press **BACK** to erase the entered letters one at a time.

### Last 20 Destinations

**<Set destination>** (Enter) **<Last 20>** (Enter)

Press **ENTER** to see the 20 most recently entered destinations. Move to the desired destination using the **JOYSTICK** and press right or **ENTER** to access the submenu.

**<Set as destination>** - Start guidance to the destination.

**<Delete location>** - Erases the entered destination.

### Destination from a Point on the Map

**<Set Destination>** (Enter) **<Point on map>** (Enter)

Use the **JOYSTICK** to move the cross on the map and specify a destination directly on the map. The centre of the cross shows the destination on the map.

The name and destination that correspond to the cross position are shown at the bottom of the map.

Press **ENTER** to access the scroll menu:

**<Scale>** - Press the **JOYSTICK** right to access the scale quick menu. Move to **<+>** or **<->** then press **ENTER** repeatedly to zoom in or out of the map. Press **BACK** to return to map view.

**<Set as destination>** - Press **ENTER**. Guidance to the destination will start automatically.

### Show Destination

**<Show Destination>** (Enter)

Show destination provides a map view of the intended destination, time to destination and distance to go. Press **BACK** twice to return to map view.

### Traffic Information

**<Settings>** (Enter) **<Traffic Information>** (Enter)

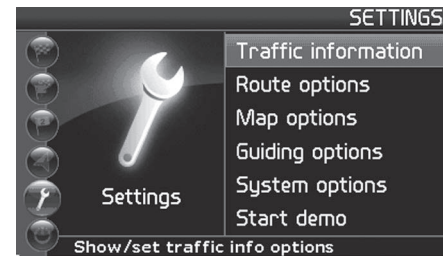

Move among the functions using the **JOYSTICK**.

**<Dynamic route guidance>** - Select **<On>** or **<Off>**. When ON this provides the option to choose an alternative route bypassing any traffic problems.

**<Traffic-info. selection>** - Select which traffic information symbols (traffic messages) the system should show on the map and take into account when calculating the route.

<Hide all> - Receive no traffic information.

<Show selected> - Choose among the symbols.

<Show all> - Receive all available traffic information.

<**Search stations**> - Search for and select transmitting stations for traffic information.

<**Current station**> - Show the current station for traffic information.

<**Reset to default**> - Restore factory settings. Press the **JOYSTICK** right. Select <OK> or <Cancel> and press **ENTER**.

 *Traffic information is not available in all areas.*

## Route Options

<**Settings**>(Enter)<**Route options**>(Enter)

Use the **JOYSTICK** to move between the functions and select the desired setting. Confirm settings by pressing **ENTER**.

<**Route**>

Select a <Fast>, <Short> or <Easy> when calculating a route.

 *Easy - Avoiding complex intersections and difficult manoeuvres, less narrow roads and junctions.*

<**Avoid motorways**> - Select if motorways are to be avoided when calculating the route.

<**Avoid toll roads**> - Select if toll roads are to be avoided when calculating the route.

<**Avoid ferries**> - Select if ferries are to be avoided when calculating the route.

<**Avoid car train**> - Select if car trains are to be avoided when calculating the route.

<**Avoid traffic problems**> - Select if consideration should be given to traffic problems when calculating the route.

<**Avoid time-restr. roads**> - Select if the system should avoid time-restricted roads when calculating the route. The correct time zone must be set for the function to work (Refer to 'System Settings', page 10.11).

<**Avoid specified areas**> - Select the areas the system is to avoid when calculating the route (Refer to 'Avoid Specific Areas', page 10.18).

<**Reset to default**> - Restore factory settings. Press the **JOYSTICK** right. Select <OK> or <Cancel> and press **ENTER**.

 *The system can only use larger roads when calculating a route extending over a long distance. If <No> is selected for toll roads and motorways, they are avoided to the greatest possible extent and are only used if there is no other reasonable alternative.*

## Map Options

<**Settings**>(Enter)<**Map options**>(Enter)

Use the **JOYSTICK** to move between the functions and select the desired setting. Confirm settings by pressing **ENTER**.

<**Facility selection**> - Press the **JOYSTICK** right to obtain the submenu.

<Show all> - All facility symbols on the map image are to show.

<Hide all> - No symbols are to show.

<Show selected> - Choose which symbols are to show.

Select using the **JOYSTICK** (right or left) and confirm settings by pressing **ENTER**.

<**Map**> - Select if the map is to show. If the map is hidden, the system guides with an arrow.



---

**<Map view>** - If in one map view on the **SCREEN**, select to view either a 2D or 3D map. If in two map view on the **SCREEN** select views for left and right maps (Refer to 'Maps', page 10.21)

**<2D Map orientation>** - Select whether north or the heading (direction of travel) should be up when looking at the map.

**<Compass>** - Select if the compass is to be shown on the **SCREEN**.

 **<2D Map orientation>** is only available when 2D view is selected in **<Map view>**.

**<Current Location>** - Select if the name of the street on which the vehicle is currently driving should be shown at the bottom of the **SCREEN**.

**<Reset to default>** - Restore factory settings. Press the **JOYSTICK** right. Select **<OK>** or **<Cancel>** and press **ENTER**.

### Guiding Options

**<Settings>**(Enter)**<Guiding options>**(Enter)

Use the **JOYSTICK** to move between the functions and select the desired setting. Confirm settings by pressing **ENTER**.

 Which areas have accident blackspots and or safety cameras marked on the map is regulated by legislation in the respective countries.

**<Time/dist. to go>** - Select **<RTA>** (Remaining time to arrival) or **<ETA>** (Estimated time of arrival). Distance to go will also show. Select **<Hide>** if this information is not to be shown.

**<Facility warning>** - Select if an audible and visual warning is to sound and show when approaching an accident blackspot or a safety camera.

**<Reset to default>** - Restore factory settings. Press the **JOYSTICK** right. Select **<OK>** or **<Cancel>** and press **ENTER**.

### System Settings

**<Settings>**(Enter)**<System settings>**

Use the **JOYSTICK** to move between the functions and select the desired setting. Confirm settings made using **ENTER**.

**<Guiding voice>** - A male or a female guiding voice can be selected.

**<Guiding volume>** - Guiding voice volume.

**<Language>** - Select the language to be used.

**<Menu colour>** - Select **<Black>**, **<Chrome>** or **<Blue>**.

**<Map colour>** - Select **<Bright 1>**, **<Bright 2>** or **<Dark>**.

**<Screen saver>** - Select whether the screen saver is to be used (comes ON after 30 seconds).

**<Help>** - Select if help texts are to show at the bottom of the **SCREEN**.

**<Distance unit>** - Select **<Miles>** or **<km>**.

**<User mode>** - Select **<Easy>** or **<Advanced>**. All destinations will be erased if changing operating modes.

**<Date & time info>** - Press the **JOYSTICK** right. Set the date and time format.

**<GPS Information>** - Press the **JOYSTICK** right to view coordinates and address of the vehicle's position, as well as the number of satellites the system is in contact with.

**<About>** - System information.

**<Reset to default>** - Restore factory settings. Press the **JOYSTICK** right. Select **<OK>** or **<Cancel>** and press **ENTER**.

## Using Advanced Mode

The navigation system requires a destination to be entered so that a route to the destination can then be calculated. Various destination options are available.

Once a valid destination has been entered <Start Guide> will be available.

Various destinations can be entered and saved as an itinerary (Refer to 'Itinerary', page 10.17).

 If the **SCREEN** is in map view press **BACK** to access the main menu.

### Destination by an Address

<**Set Destination**>(Enter)<**Address**>(Enter)



The last selected country will be remembered. If searching for a destination outside the current country move to <Country> and press **ENTER**.

 Press the **JOYSTICK** right when an arrow is shown on the right of the line, a list of the five last entered countries will show. Select the required country, if available, from the list and press **ENTER**.

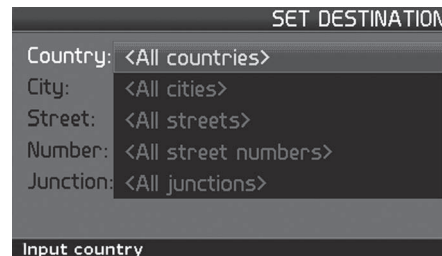

Use the **JOYSTICK** to spell out the desired country from the character table. Press **ENTER** for each letter.

 When there are no more alternatives, the system fills in the missing letters itself.

A list of countries matching that letter combination is shown at the bottom of the **SCREEN**. A scroll bar on the right shows that there are several alternatives in the list. The number shows how many.

Using the **JOYSTICK** move down and select directly from the list in the menu. Select and press **ENTER**.

---

While scrolling through the list, return to the character table by pressing **BACK**. Press **BACK** to erase the entered letters one at a time.

### Select City

Select <City> and press **ENTER**.

Use the **JOYSTICK** to spell out the desired city from the character table. Press **ENTER** for each letter.

A list of Cities matching that letter combination is shown at the bottom of the **SCREEN**.

 Press the **JOYSTICK** right when an arrow is shown on the right of the line. A list of the five last entered cities will show. Select the required city, if available, from the list and press **ENTER**.

 When there are no more alternatives, the system fills in the missing letters itself.

A scroll bar on the right shows that there are several alternatives in the list. The number shows how many.

Using the **JOYSTICK** move down and select directly from the list in the menu. Select and press **ENTER**.

While scrolling through the list, return to the character table by pressing **BACK**. Press **BACK** to erase the entered letters one at a time.

 The definition of city or area may vary from country to country or even within a country.

 Countries, cities and street names are erased when the destinations in 'Last 20' are erased.

### Select Street

Move to <Street> and press **ENTER**.

 It is also possible to search for street addresses throughout a country without specifying a particular city.

 Street addresses are not stored in the system for some small towns. The town centre, however, can always be specified as the destination.

Once a street has been selected it is then possible to move to <Start Guide>, <Itinerary> or <Information>.

When <Start guide> is selected, the system begins calculating the route and distance to the destination (during this time, a yellow symbol is shown at the top of the **SCREEN**).

If a detour is made from the planned route during the trip, the system automatically calculates a new route.

 If neither a street number or an intersecting street is specified the system guides to the middle of the street chosen.

### Select Street Number or Junction

If the street number of the selected address is known, it can also be entered to make guidance more exact. An intersecting street can also be entered instead of the street number.

Move to <Number> and press **ENTER**. Existing street numbers are then shown. Select a number using the **JOYSTICK** (right or left) and press **ENTER**.

Once a valid number has been entered move to:

<Set> - Confirm entered number.

<Information> - Provides information on the destination. Press **BACK** and then <Set> or press **BACK** again to cancel.

Move to <Junction> and press **ENTER**.

The roads that intersect the selected street are shown in a list. Select from among the streets and press **ENTER**.

### Destination by a Post Code

Using the **JOYSTICK** move to <City> and press **ENTER**. Move to <Post code> and press **ENTER**.



Use the **JOYSTICK** to select the desired letters and numbers from the character table and press **ENTER**. Move down and select a post code from the list. Press **ENTER**.

While scrolling through the list, press **BACK** to return to the table of characters. Press **BACK** to erase entered characters.

Move to <Street> and press **ENTER**. Choose letters using the **JOYSTICK** and press **ENTER** or move down and choose a street name directly from the list if options are available.

 *In some countries the entire post code cannot be specified.*

### Destination by a Facility

<Set destination>(Enter)<Facilities>(Enter)

Facilities is a collective name for places such as petrol stations, hotels, restaurants, Aston Martin Dealers, hospitals, vehicle parking, etc.

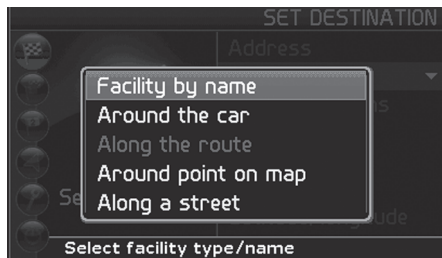

<Facility by name> - Move to <Type> or <Name> and press **ENTER**. Enter the name of a facility or select a facility type from the list in the menu. The list can vary and only shows the facilities of the selected city or area.

<Around the car> - The system searches in a circle with a maximum radius of 250 km. The search is stopped when 40 facilities are found.

Press **ENTER** and select <Last 5> or <All types>. Select a Facility from the list and press **ENTER**. Select from the list of Facility names and press **ENTER**. Select <Add to itinerary> or <Facility information>.

 *It is also possible to search for facilities around the vehicle, along the itinerary and along the motorway using the quick menu (Refer to 'Quick Menus', page 10.20).*

<Along the route> - Use the procedure described for <Around the car>. When a destination has been specified, the system can search for facilities within an area maximum 1 km from the route.

<Around point on map> - The system searches the same way as <Around the car>, but around a specified point on the map. Enter map scroll (press the **JOYSTICK** left, right, up or down) and scroll to a destination on the map. Press **ENTER** and select <Facilities around>.

<Along a street> - The system searches along a specified street. Select an option using the **JOYSTICK** and press **ENTER**.

### Destination by a Stored Location

<Set destination>(Enter)<Stored destinations>(Enter)

---

A stored location is a destination stored previously, i.e. your home address, an airport, etc. If no destinations are stored this option will not be available.

A list of stored destinations is shown. Use the **JOYSTICK** to move to a stored destination. Press **ENTER** to access the submenu.

Select an option and press **ENTER**.

**<Add to itinerary>** - Add the stored destination in the itinerary.

**<Information>** - Provides information on the stored destination.

**<Edit>** - Change the name, etc. of the stored destination.

**<Sorting>** - Sort stored destinations by icon or name.

**<Delete Destination>** - Erase a stored destination.

**<Del. all>** - Erase all stored destinations.

### Last 20 Destinations

**<Set destination>**(Enter) **<Last 20>**(Enter)

Press **ENTER** to see the 20 most recently entered destinations. Move to the desired destination using the **JOYSTICK** and press right or **ENTER** to access the submenu.

**<Add to itinerary>** - Adds the destination to the itinerary.

**<Information>** - Provides information on the destination.

**<Delete Location>** - Erase the entered destination.

### Return Trip

**<Set destination>**(Enter) **<Return trip>**(Enter)

Press **ENTER** to obtain guidance back to the starting point.

Select **<Start guidance>** and press **ENTER**. The system then starts guiding back to the destination Start guidance was last selected.

### Destination from a Point on the Map

**<Set Destination>**(Enter) **<Point on map>**(Enter)

The centre of the cross shows the current destination on the map. The name and destination that correspond to the cross position are shown at the bottom of the map.

Use the **JOYSTICK** to move the cross to the desired destination and press **ENTER** to access the Scroll menu. Move to **<Set as destination>** and press **ENTER**.

### Destination by Coordinates

**<Set Destination>**(Enter) **<Latitude / longitude>**

Using the **JOYSTICK** move from row to row and up or down to set coordinates.

**<OK>** - Shows the destination of the specified coordinates on the map. Press **ENTER** to access the scroll menu. Move to **<Set as destination>** and press **ENTER** to select as a destination. Press **BACK** to return to coordinate input.

**<Cancel>** - Return to the previous screen.

## Store a Destination

Up to 250 destinations can be stored for re-use in different itineraries. An audible signal notifies the driver that a stored location is approaching and that further information can be linked with the stored location.

### Saving a Location from the Itinerary

**<Itinerary>**(Enter)

Using the **JOYSTICK** move up or down the itinerary to the destination you want to store and press **ENTER** to access the submenu. Select **<Store>** and press **ENTER**.

Select the symbol to be shown in the map and press **ENTER**. Enter the required name. Scroll to **<Store>** and press **ENTER**.



### Saving a Location from the Map

Press the **JOYSTICK** in any direction to enter map scroll. Move to the destination you want to store and press **ENTER**. Select **<Store>** from the Scroll menu and press **ENTER**.

Move to the symbols. Select and press **ENTER**. Enter the required name. Scroll to **<Store>** and press **ENTER**.

### Adjust the Location

Select **<Edit>**(Enter)**<Adjust>**(Enter) to move the position of the stored location on the map.

Use the **JOYSTICK** to move the cross (on the map) to the new position of the stored location and press **ENTER**. Select **<Store location>**(Enter)**<Store>**(Enter) to save the change. Press **BACK** to return to the main screen.

### Add Information

**<Set Destination>**(Enter)**<Stored locations>**(Enter)

Move to the stored location in the list and press **ENTER**. Select **<Add info.>** and press **ENTER** to add further information on a stored location to the list provided.

Select **<Store>** and press **ENTER** to save the change(s). Press **BACK** repeatedly to return to the main screen.

 Press **BACK** to erase the original name and replace it with a new one.

## Itinerary

<Itinerary>(Enter)

The Itinerary menu is available once a destination has been entered. An itinerary with several intermediate destinations can be created to avoid entering destination after destination during your trip. One final destination with up to six intermediate destinations can be specified in an itinerary.

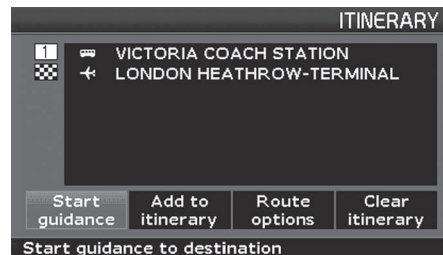
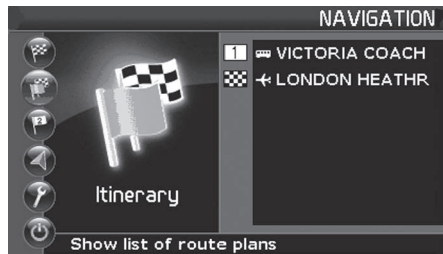

<Start guidance> - Starts guidance to the destination.

<Add to itinerary> - Add another destination using the <Set destination> screen.

<Route options> - Settings for route priorities.

<Clear itinerary> - Erase the entire itinerary.

## Edit an Itinerary

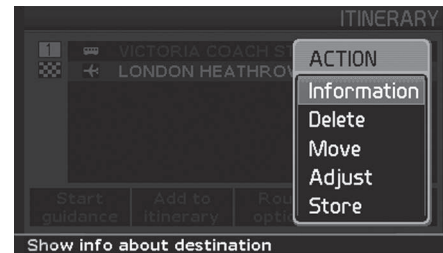

Select a destination in the itinerary and press **ENTER** to access options.

Select an option and press **ENTER**.

<Information> - Provides information on the destination.

<Delete> - Clears the destination from the itinerary.

<Move> - Changes the position of the destination in the itinerary.

<Adjust> - Changes the destination of the destination on the map.

<Store> - Saves the destination under <Stored Destinations>.

## Next Destination

<Next destination>(Enter)

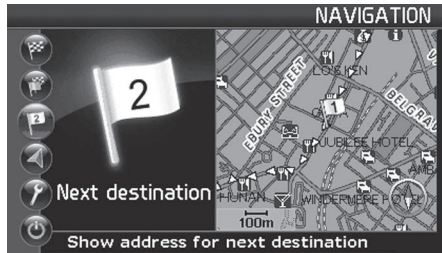

Next Destination shows information on the next destination in the itinerary such as name, remaining journey time and distance from the current position to the destination.



Press the << or >> buttons to view more destinations (if available).

Move to <Map> and press **ENTER** to view the whole map image and obtain map scroll. Press **ENTER** again to obtain the map scroll menu (Refer to 'Maps', page 10.21).

## Avoid Specific Areas

### Specify an Area on the Map

<Settings>(Enter)<Route options>(Enter)<Avoid specified areas>

Press the **JOYSTICK** right, move to <Selected> and press the **JOYSTICK** right. Select <Map>.

Using the **JOYSTICK**, move the centre point of the hairline cross to the centre of the area to be avoided. The name of the destination the centre point rests on is shown at the bottom of the map.

The rectangle shows the size of the area. Press **ENTER** to obtain the submenu.

Select option in the submenu and press **ENTER**.

<Scale> - Specify the size of the area to be avoided. Move to + or - and press **ENTER** repeatedly to adjust the scale. Press **BACK** to accept.

<Set area to avoid> - Saves specified area. Select <OK>.

<Adjust size> - Change the size of the area using the **JOYSTICK**. Press **BACK** to undo the change, or press **ENTER** and select <Set area to avoid> to save.



---

**<Adjust area>** - Move the area using the **JOYSTICK**. Press **BACK** to undo the move, or press **ENTER** and select **<Set area to avoid>** to save.

### Specify an Area Address

**<Settings>**(Enter)**<Route options>**(Enter)**<Avoid specified areas>**

Press the **JOYSTICK** right, move to **<Selected>** and press the **JOYSTICK** right. Select **<Address>**.

Enter the address of the area to be avoided. The address then constitutes the centre of the area.

Use the **JOYSTICK** to move between the rows and press **ENTER** to enter the address. Once a valid area has been selected, move to **<Set>**, press **ENTER**.

The specified area is shown on the map. Press **ENTER** to obtain the submenu.

Select **<Scale>**, **<Set area to avoid>**, **<Adjust size>** or **<Adjust area>**.

**<Cancel>** - Returns to saved areas.

### Select an Area to Avoid

**<Settings>**(Enter)**<Route options>**(Enter)**<Avoid specified areas>**

Press the **JOYSTICK** right:

**<None>** - Press **ENTER** to deselect areas already selected.

**<Selected>** - Press the **JOYSTICK** right to view specified areas. Press the **JOYSTICK** right to select or deselect areas already saved.

### Avoid Area Options

**<Settings>**(Enter)**<Route options>**(Enter)**<Avoid specified areas>**

Press the **JOYSTICK** right, move to **<Selected>** and press the **JOYSTICK** right.

Scroll to a specified area or an empty specified area and press **ENTER**. Choose option on the submenu using the **JOYSTICK** and press **ENTER**.

**<Map>** - Press **ENTER** and use the **JOYSTICK** to select the area to be avoided directly on the map. This will overwrite any current specified area.

**<Address>** - Enter the address of the area to be avoided. The address constitutes the centre of the area. This will overwrite any current specified area.

**<Edit>** - Change the name of the saved area. Press **BACK** to erase the current area name. Enter a new name and select **<Set>** to accept or **<Cancel>**.

**<Delete>** - Erase a saved area. Confirm with **<OK>**.

## Information

The address, coordinates and in some cases the telephone number of a facility is can be viewed when ever *<Information>* is available.

*<Map>* - Press **ENTER** to see the facility destination on the map.

*<2nd Fac>* - Shows related facilities in the area around the first facility.

*<Call>* - If the information screen contains a valid phone number press *<Call>* to call that number. The call will be place through the vehicle hands-free phone system.

## Current Position

*<Current position>* (Enter)

The map image shows the vehicle's position and information on the destination, for example name and coordinates. *<GPS>* shows the number of satellites the system is in contact with, on the left side of the **SCREEN**.

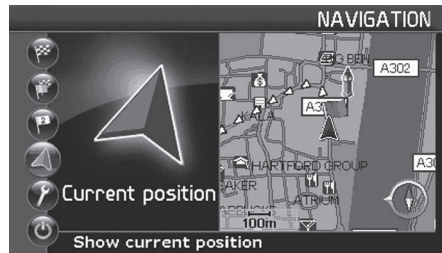

## Quick Menus

When in map mode press **ENTER** to access the quick menus. Use the **JOYSTICK** to scroll through the menus.



**[1] MAP SCALE** - Move to *<+>* or *<->* then press **ENTER** repeatedly to zoom in or out of the map. Scale is shown at the bottom of the **SCREEN**.

Select the 'green flag + finish flag' option to view the complete route. Select the 'vehicle + finish flag' option to view the remaining route from the current position to the destination.

If two map images are shown the **MAP SCALE** symbol shows at both ends of the quick menu.

**[2] GUIDANCE** - Press **ENTER** to repeat a voice guidance.

**[3] MAP AND ROUTE OUTLINE** - (Advanced mode only)

*<Route Outline>* - The destination and remaining distance are shown at the top of the **SCREEN**. The next guidance point is highlighted and is followed by a list of remaining guidance points. In addition the distance between guidance points and a type of manoeuvre arrow are shown.

Guidance points are erased as they are passed. If a deviation is made from the given route, the system calculates a new one.

**<Map View>** - Choose between one or two maps. Select *<One map>* or *<Two maps>* view. Different degrees of magnification can be selected for each map image of the same area.

**<Surveillance 1, 2 or 3>** View areas set previously for traffic surveillance (Refer to 'Traffic Surveillance', page 10.28).

#### **[4] DETOUR - (Advanced Mode Only)**

When the detour function is used, the system calculates an alternate route to avoid part of the calculated route. This is used to avoid construction, for example. Move to the detour quick menu using the **JOYSTICK**.

Set the number of kilometres the route is to be avoided using the **JOYSTICK** and press **ENTER**. The system then calculates a new route and avoids the original route for the specified number of kilometres starting from the current position. A destination must be specified for the function to work.

**<Avoid Specific Street>** Select *<Avoid>* and press **ENTER**. A list of streets that are part of the route are shown. Move to the street to be avoided using the **JOYSTICK** and press **ENTER**.

#### **[5] TRAFFIC INFORMATION - (Advanced Mode Only)**

Select which traffic information symbols are to show on the map image. It is also possible to read the traffic messages shown on the map image (Refer to 'Traffic Information', page 10.25).

#### **[6] FACILITIES - (Advanced Mode Only)**

Search for facilities which are easily accessible from the motorway. Select from *<Around the car>*, *<Along the route>* or *<Along m. way>*. When a calculated route extends over more than one motorway, the system only searches along the current section of motorway.

If no route is calculated, the system searches along the motorway the vehicle is travelling on. The list shows rest areas, petrol stations and restaurants along the motorway along with the distance. Select a facility using the **JOYSTICK**.

## Maps

The **DISPLAY** can show either one or two maps. In two map view each map view can have different viewing scales. Select one or two maps using the  quick menu.

### **One Map Settings**

Move to *<Settings>(Enter)<Map options>(Enter)<Map view>*. Press the **JOYSTICK** right or left to select from *<2D North>*, *<2D Heading>* or *<3D>*.

 *2D - from directly above. 3D - obliquely from above.*

When viewing the map in 3D the map elevation is adjustable.

To change the map elevation move to *<Settings>(Enter)<Map options>(Enter)<Map view>(Enter)*.

If not already selected select 3D and press **ENTER**. An elevation adjustment window will show in the bottom left corner of the **DISPLAY**. Use the **JOYSTICK** to move up or down to change the map elevation, press **ENTER** to select. Press **BACK** repeatedly to return to map view.

## Two Map Settings

### Right Map

Move to <Settings>(Enter)<Map options>(Enter)<Right map view>. Press the **JOYSTICK** right or left to select from <2D North>, <2D Heading> or <3D>.

In 3D map view the direction of travel is always upwards on the screen. Map elevation can be adjusted as described for One map Settings.

In 2D map view select whether the direction of travel or North is to be upwards on the screen.

### Left Map

Move to <Settings>(Enter)<Map options>(Enter)<Left map view>. Press the **JOYSTICK** right or left to select from <2D North> or <2D Heading>.

## Map Scroll

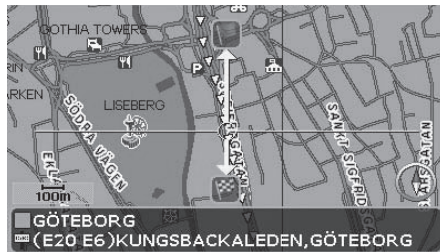

While in map view move the **JOYSTICK** in any direction to start map scroll.

The **JOYSTICK** can then be used to move the cross freely over a large area with a detailed scale.

 If using map scroll in while in 3D view the view will default to 2D.

The destination that corresponds to the cross position is shown at the bottom of the map.

## Follow Route

To follow the current route on the map move the centre of the cross to rest over the route. Once the cross rests over the route either the horizontal or vertical cross line will show thicker. If the thicker line is vertical press and hold the **JOYSTICK** left or right, if the thicker line is horizontal press and hold the **JOYSTICK** up or down. While the **JOYSTICK** pressed the cross will follow the intended route.

Flag symbols show whether the line points towards the start of the route or towards the destination.

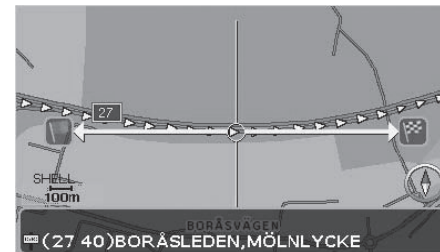

## Scroll Menu

Press **ENTER** to access the scroll menu.

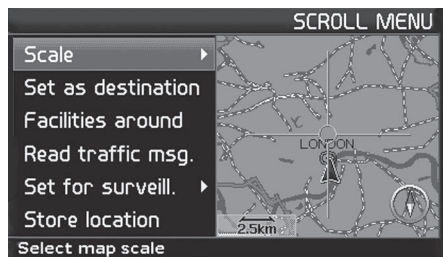

**<Scale>** - Function to temporarily change the map scale. Press **BACK** to return to the original scale and to return to the vehicle's position on the map.

**<Set as destination>** - Select a location on the map as a destination or intermediate destination.

## Advanced Mode Only

**<Facilities around>** - The system searches for facilities around a specific point on the map. The system searches in a circle with a radius of 2 km. If less than 40 facilities are found, the search is extended to a radius of maximum 250 km.

**<Read traffic msg.>** - Use the **JOYSTICK** to select from among the traffic messages shown on the **SCREEN**.

**<Set for surveill.>** - Specify an area on the map that monitors the traffic situation.

**<Store location>** - Save a location on the map. Select an option using the **JOYSTICK** and press **ENTER**.

## Map Symbols



Airport



Amusement park



Aston Martin Dealer



Athletics stadium



Automobile club



Bowling



Bus station



Casino



Cinema



City centre



Compressed natural gas









Conference / Exhibition centre

	Ferry terminal		Marina		Rest area
	Gasol/LPG		Museum		Restaurant
	Golf course		Night club / Music club		Shopping centre
	Historical monument		Outdoor recreation area		Ski resort
	Hospital		Park & ride		Theatre / Opera
	Hotel		Parking garage		Toll booth <sub>1</sub>
	Ice skating		Petrol / Gas station		Tourist attraction
	Large company		Public sport airport		Tourist information
			Railway / Train station		

---

<sub>1</sub>. Cannot be selected as a destination.

-  Town hall / City hall / Civic / Community centre / Court house
-  University / college
-  Vehicle hire / rental
-  Vehicle parking lot
-  Winery
-  Zoo

## Traffic Information

Traffic information is always received and shown, irrespective of whether in easy or advanced mode. The settings for how traffic information should be shown can only be changed in advanced mode. How the traffic information is shown depends on how it is transmitted.

 *Traffic information (TMC) is available as an option and is only supported in certain countries.*

### Delay Time

Some traffic messages transmitted also contain information on escalation. On all scales up to 5 km the yellow or red line along the route is also shown in addition to the symbol. The length of this line corresponds to the extent of the traffic problem.

## Read Messages

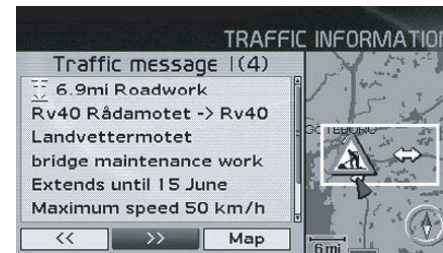

While in map view move the **JOYSTICK** in any direction to start map scroll. Press **ENTER** to access the Scroll menu.

Move to <Read traffic msg.> and press **ENTER**. Use the **JOYSTICK** to move among the different traffic messages.

Relevant messages are marked with a red or yellow frame. Press **←←** or **→→** to be able to move among the messages. Press **ENTER** for detailed traffic information.

The number of traffic messages relevant to the map area is shown on the **SCREEN**. Detailed information on the traffic problem is also shown.

**Traffic message can also be read by using the quick menu.**

Press **ENTER** to access the quick menu and move to the  symbol, press **ENTER**.







The extent of the problem and distance from the current position is shown at the top. Duration, roads affected and limitations regarding speed, vehicle width, vehicle height, etc. are shown in the extent to which they are available. The amount of traffic information available depends on the scale of the map (larger area - more information).

### Traffic Symbols

Traffic information is accessible during the trip if it is sent within the area in question. If there are traffic messages within the area shown on the map, they are marked with symbols.

The symbols can have two colours. Yellow (important information) and red (urgent information).

Change the scale to access traffic information within a larger or smaller area. Traffic information is always available, even if no destination is specified.

	Area message
	Incident
	Other information
	Slow traffic
	Slow traffic in both directions
	Stationary Traffic

### Station for Traffic Information

**<Settings>**(Enter)**<Traffic Info.>**(Enter)**<Search station>**

The traffic message system will automatically search for stations broadcasting traffic information, but a specific station can be selected.

Select **<Search station>** and press **ENTER**. Use the **JOYSTICK** to select a station and press **ENTER**.

Press **BACK** to return to the previous screen.

### Options

**<Settings>**(Enter)**<Traffic information>**(Enter)**<Traffic-info. selection>**

Select which traffic information symbols (traffic messages) the system should show on the map and take into account when calculating the route. These are selected with a cross. Use the **JOYSTICK** to select from among the symbols. Select or deselect using the **JOYSTICK** (right or left) and confirm using **ENTER**.

 Traffic information symbols can also be selected via the quick menu (Refer to 'Quick Menus', page 10.20).

### Avoid Traffic Problems

**<Settings>**(Enter)**<Route options>**(Enter)**<Avoid traffic problems>**



When a traffic message is received that affects the planned route, the system can calculate an alternate route.

<**No**> - If the system is not to avoid roads with traffic problems when calculating the route.

<**Yes**> - If the system is to avoid roads with traffic problems when calculating the route.

### Automatic Notification

<**Settings**>(Enter)<**Traffic Info.**>(Enter)<**Dyn. route guiding**>

Select if transmitted traffic information should be shown.

<**Yes**> - To make it possible to select an alternate route around any traffic problems.

<**No**> - Auto notification set to OFF.

### Messages Along the Route

Once a traffic information symbol has been selected the following screen shows:



<**Yes**> - The system calculates an alternate route to avoid the traffic problem.

<**No**> - The system continues with the original route.

<**Map**> - Sets to map scroll mode. Move among the different messages.

### Traffic Message Selection

<**Settings**>(Enter)<**Traffic Info.**>(Enter)<**Traffic info. selection**>

Select the type of traffic message which should be shown and to be considered if calculating a new route.

<**Show all**> - All traffic information is available.

<**Hide all**> - No traffic information is available.

<**Show selected**> - Press the **JOYSTICK** right to enable symbol selection. Move up and down the list and press the **JOYSTICK** right to select. Press **ENTER**

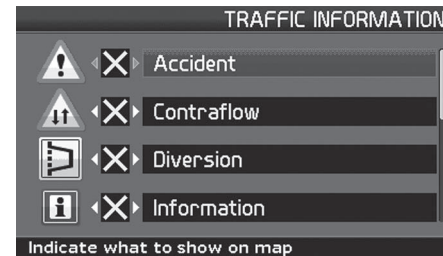

Accident



Congestion



Contraflow



Diversion



Information



Narrow road



Other hazard



Parking



Road work



Slippery road

## Traffic Surveillance

In order to quickly check the traffic situation in an area, one or more sections of road can be monitored. Select map scroll to set the map over the area to be monitored, such as a section of road where there is a risk of traffic queues.

While in map view move the **JOYSTICK** in any direction to start map scroll. Use the **JOYSTICK** to move the cross on the map. Set the cross over the area to be monitored and press **ENTER** to access the Scroll menu. Move down to <Set for surveill.> and press **ENTER** or the **JOYSTICK** right to access the surveillance menu.

### Store Surveillance

Three different areas can be stored.

Select and press **ENTER**.

### Show Stored Surveillance Map

Press **ENTER** in map view to access the quick menu. Move to the map menu using the **JOYSTICK**. Select <Surveillance No. 1>, <2> or <3> to see one of the areas set for surveillance.

## Frequently Asked Questions

**(Q) The position of the vehicle on the map is wrong.**

**(A)** The GPS system shows the position of the vehicle with an accuracy of about 20 m. There is a greater chance of error when driving on roads lying parallel to another road, winding roads, roads on several levels and after driving a long distance without making any distinctive turns. High mountains, buildings, tunnels, viaducts, over or underpasses etc. also have a negative affect on the reception of GPS signals, which means that accuracy in calculating the position of the vehicle may decrease.

**(Q) The navigation system does not always calculate the fastest or shortest route.**

**(A)** When calculating a route, distance, width of road, type of road, number of right or left turns, roundabouts etc. are all taken into account in order to produce the best theoretical route. A more efficient selection of route may be possible based on experience and knowledge of the area.

---

**(Q) The navigation system uses toll roads, motorways and ferries even though I chose to avoid them.**

**(A)** When calculating routes over longer distances, for technical reasons, the system can only use larger roads when calculating a route extending over a long distance. If <NO> is selected for toll roads and motorways, they are avoided to the greatest possible extent and are only used if there is no other reasonable alternative.

**(Q) The position of the vehicle on the map is incorrect after transportation.**

**(A)** If the vehicle is transported, for example by ferry or train, or in such a way as to impede the reception of GPS signals, it can take up to five minutes before the position of the vehicle is correctly calculated.

**(Q) The position of the vehicle on the map is incorrect after the vehicle battery has been disconnected.**

**(A)** If power has been cut from the GPS antenna, it can take more than five minutes for the GPS signals to be received correctly and the position of the vehicle to be calculated.

---

**(Q) The map image does not correspond with the real situation.**

**(A)** Factors such as the constant expansion and rebuilding of the road network, new traffic regulations constantly being introduced etc. means that the digital map database is not always complete. The information stored in the maps is constantly being developed and updated. An Aston Martin Dealer can provide further information.

**(Q) The scale of the map sometimes changes.**

**(A)** Scale is affected by vehicle speed. At speeds over 140 km/h the largest possible degree of magnification is 250 m. Once speed decreases to 120 km/h, the system is once again able to show all degrees of magnification. If no detailed map information is available, the degree of magnification automatically selected regardless of speed.

**(Q) The expected menu option is missing.**

**(A)** Look at the settings that have been made. Select <Reset to default> to restore the original settings.

**(Q) The system shows the route I am already on when I request <Calculate new route> or <Detour>.**

**(A)** The system cannot find a good alternative to the current route.

---

**(Q) The vehicle symbol on screen jumps forwards or spins.**

**(A)** The navigation system may need a few seconds to sense the position and movement of the vehicle before driving off. Set both the navigation system and the engine to OFF. Start again, but stay stationary for a while before starting to drive.

**(Q) I'm going to make a long journey but I do not want to specify a special destination to the Cities I am thinking of travelling through. How do I most easily create an itinerary?**

**(A)** Specify the destination directly on the map using the hairline cross. The system automatically guides you to the final destination even though you are driving beside the intermediate destinations.



ASTON MARTIN



ASTON MARTIN



ASTON MARTIN

# Maintenance

Introduction .....	11.2	Brake Pad 'Bedding-in' .....	11.11	Headlamp Bulb.....	11.28
Vehicle Jacking.....	11.3	Tyres.....	11.11	Other External Bulbs .....	11.28
Servicing Precautions.....	11.3	Winter Tyres .....	11.13	Boot Lamps.....	11.29
Dangerous Substances.....	11.4	Tyre Sealant Kit .....	11.13	Internal Lamps .....	11.29
Emergency Items .....	11.5	Vehicle Recovery .....	11.15	Tourist Headlamp Adjustment.....	11.30
Owner Maintenance .....	11.5	Vehicle Battery.....	11.18	Door Window Reset .....	11.30
Bonnet Release .....	11.6	Vehicle Battery Charge .....	11.20	Front Seat Reset .....	11.31
Fluid Levels .....	11.7	Battery Protection Mode .....	11.21	Bodywork Maintenance .....	11.31
Windscreen Blade Replacement.....	11.10	Fuse Boxes.....	11.22	Vehicle Cleaning.....	11.32
				Vehicle Storage .....	11.34

## Introduction

Each item in the service schedules must be performed on time as failure to do so may void the new vehicle warranty or other warranties. It is the owner's responsibility to see that the vehicle is maintained correctly and in accordance with the manufacturer's service schedules.

Due to the sophistication of the various systems and the specialised equipment required to maintain this vehicle, owner maintenance should be restricted to the routine procedures described in this owner's guide.

If you think that this vehicle is not functioning correctly, please return it to an Aston Martin Dealer to be checked professionally.

### Restraint Systems

Aston Martin recommend that the inflatable (airbags) restraint systems and seat belt components installed to this vehicle are replaced at 10 (ten) year intervals from the date of manufacture on the certification label.

### Electronic Fuel Injection

**⚠ Warning: If the fuel system is allowed to run dry irreparable damage to the fuel pumps may occur.**

**⚠ Warning: Any modifications or additions to the fuel system not specifically designed by Aston Martin are prohibited. If carried out, they may cause damage to the fuel system which in some circumstances could result in fire. All Service Action Campaigns must be undertaken by an Aston Martin Dealer.**

The electronic fuel injection system requires special equipment and test facilities to set up and maintain so that the vehicle gives maximum performance coupled with economy, reliability and safe vehicle emissions. You are, therefore, strongly advised to entrust all service work to an Aston Martin Dealer.

### Parts and Lubricants

When undertaking a servicing task only parts, materials, lubricants, etc. that are specifically recommended by Aston Martin should be used. Failure to do so can result in damage to your vehicle and may invalidate your new vehicle warranty or other warranties (Refer to 'Aston Martin Warranty', page C.1).

**⚠ Your vehicle's warranty may be invalidated if damage is caused by the use of incorrect engine oil. Low quality or obsolete oils do NOT provide the protection required by modern, high performance engines. Failure to use engine oil that meets the required specification could cause excessive engine wear, a build up of sludge and deposits, and increased pollution. It could also lead to engine failure.**

## Vehicle Jacking

**⚠ Warning:** Make sure that no persons are in the vehicle before jacking commences.

**⚠ Warning:** Make sure that the park brake is ON and that the vehicle transmission is in Park (P).

**⚠ Warning:** Make sure that the vehicle is parked on firm and level ground to give a secure base for the jack.

**⚠ Warning:** Do not raise the vehicle by placing a vehicle jack under the suspension arms.

If this vehicle is to be raised using a vehicle jack make sure that the following jacking points are use.

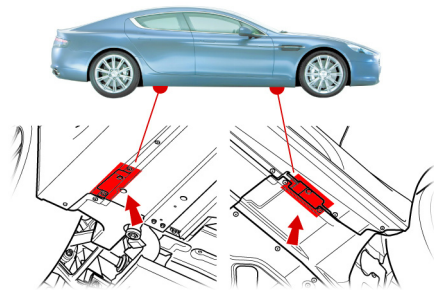

## Servicing Precautions

To avoid personal injury, the following safety precautions must be observed when the bonnet is open and the engine is operating or the ignition is ON.

**⚠ Warning:** Protect yourself against dangerous substances (Refer to 'Dangerous Substances', page 11.4).

**⚠ Warning:** Keep hands, hair, tools, items of clothing and jewellery clear of all drive belts, pulleys and operating mechanisms. The cooling fans may operate even though the engine is not operating.

**⚠ Warning:** Avoid skin contact with all exhaust system and engine components, engine fluids and escaping steam. They may be hot and will burn you.

**⚠ Warning:** Do not breathe exhaust fumes. Exhaust fumes contain carbon monoxide. Carbon monoxide is a dangerous gas, which is colourless and odourless and can cause unconsciousness and may be fatal. Never start or leave the engine running in an enclosed, unventilated area.

**⚠ Warning:** Do not work beneath the vehicle with a vehicle lifting jack as the only support. Place suitable stands under the vehicle.

## Dangerous Substances

**⚠ Warning:** *Keep children and pets clear of the vehicle. Do not let anyone inside the vehicle unless specifically working to your instructions.*

**⚠ Warning:** *Whenever possible work in the engine compartment with the engine cool, the ignition OFF and the vehicle battery disconnected.*

**⚠ Warning:** *Petrol is highly flammable and, in confined spaces, is also explosive and toxic. In the event of spillage, set the engine to OFF, use no naked flame or light. Do not smoke. Do not inhale fumes.*

**⚠ Warning:** *Dangerous substances should be kept out of reach of children.*

**⚠ Warning:** *Many liquids and other substances used in motor vehicles are poisonous and should under no circumstances be consumed and should, so far as possible, be kept from contact with the skin. These substances include battery electrolyte, antifreeze, oil, brake and clutch fluid, petrol, windscreen washer additives, lubricants, refrigerant and various adhesives.*

**⚠ Warning:** *Particular care should be taken to avoid unnecessary contact with used engine oil. Always read carefully the instructions printed on labels or stamped on components and follow them carefully. Such instructions are included for reasons of your health and personal safety. Never disregard them.*

## Engine Oils

**⚠ Warning:** *Prolonged and repeated contact with used engine oils can cause serious skin disorders, including dermatitis and cancer. Avoid excessive contact, wash thoroughly after contact. Keep out of reach of children. When your oil is changed, be sure that it is done by an experienced person. In addition, observe all laws regarding the disposal of waste oil and toxic fluids.*

## Protect The Environment

**⚠ Warning:** *It is illegal to pollute drains, water courses, or soil. Use authorised waste disposal facilities, including civic amenity sites and garages providing facilities for receipt of used oil. If in doubt, contact your local authority for advice.*



## Emergency Items

The following emergency items are located in the boot.

[1] - Tyre Sealant Kit (Refer to 'Tyre Sealant Kit', page 11.13)

[2] - First Aid Kit (located behind the left side trim panel)<sup>1</sup>

[3] - Warning Triangle.

⚠ **Always follow local regulations when placing a warning triangle.**

[4] - Fuel Fill Funnel (located under the trim panel in the boot floor. In the top left or right side of the boot floor trim panel pull up on the trim carpet to lift the panel.)

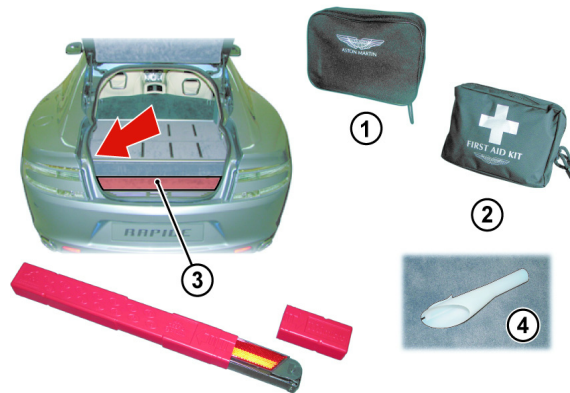

<sup>1</sup>. Option.

## Owner Maintenance

In the interests of safety and reliability, it is advisable to carry out the following checks at the intervals suggested (more frequently if your vehicle is heavily used or operating in adverse conditions), and always before starting on a long journey. Refer to the following pages for advice and check procedures.

### Before Use Check:

- Operation of lamps, horn, indicators, wipers, washers and warning symbols
- Check there is sufficient fuel for the intended journey, particularly at night and before entering motorways
- Operation of the seat belts
- Operation of the brakes
- Check for fluid deposits underneath the vehicle

### Weekly Checks

(daily if covering high mileage or touring)

- Tyres
- Coolant level
- Brake fluid level
- Power steering level
- Operate Air Conditioning
- Windscreen washer fluid level

- Check operation of windscreen washers

## Engine Oil Level

**!** *It is important to check the engine oil level regularly. Running the engine with engine oil below the lower mark or above the upper mark can cause serious engine damage.*

Check the engine oil level every fourth fuel tank fill or weekly - whichever is the sooner.

## Tool Kit

A vehicle tool kit is located under the trim panel in the boot floor. In the top left or right side of this panel pull up on the trim carpet to lift the panel (A).

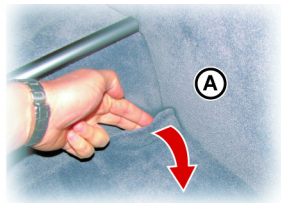
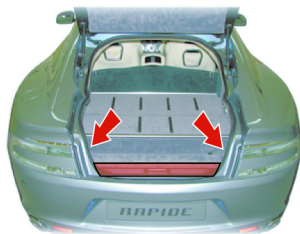

The tool kit consists of:

**Towing Eye** - (Refer to 'Vehicle Recovery', page 11.15).

**Screwdriver** - For the removal of the front registration plate when installing the front towing eye.

**Road Wheel Lock Nut Socket** - For the removal of a road wheel(s) when servicing or maintenance is required<sup>1</sup>.

## Battery Conditioner

(Refer to 'Battery Conditioner', page 11.20)

<sup>1</sup>. Option.

## Bonnet Release

**!** *Warning: Do not pull on the bonnet secondary catch to assist in closing the bonnet. This may displace the bonnet secondary catch. If the catch is displaced it may not work correctly.*

**!** *Do not press down hard on the bonnet if it has not closed correctly. This may damage the bonnet.*

**!** *Take care not unintentionally to pull on or catch the bonnet release lever.*

To open the bonnet pull the lever (A (left front footwell)) to release the bonnet latch. The bonnet will rise but stay secured by the bonnet secondary catch. Lift slightly on the bonnet front edge whilst pulling upward on the bonnet secondary catch (B) to release it. Lift the bonnet until fully open. The bonnet is held open by two gas struts.

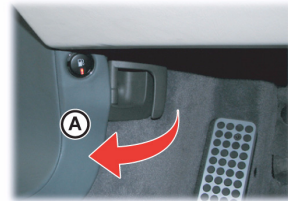

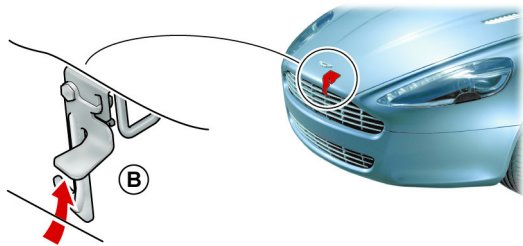

 If the windscreen wipers are operating, they will temporarily rest in the park position while the bonnet is unlatched.

 Before closing the bonnet, remove any tools, cleaning cloths, etc. from the engine compartment. Make sure that no one is obstructing the 'closing' area and that hands, clothing etc. are clear.

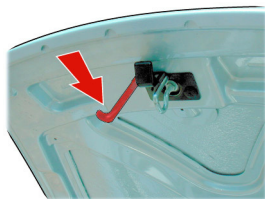

 If the bonnet does not fully close or it opens during driving the message centre (right) will show BONNET OPEN.

To close the bonnet lower the bonnet until it starts to fall under its own weight. At that point let the bonnet fall to close.

If the bonnet does not shut, open the bonnet again and repeat the closure procedure, this time assist using light hand pressure as the bonnet falls.

## Fluid Levels

 **Warning: Engine components may be hot and could cause severe burns.**

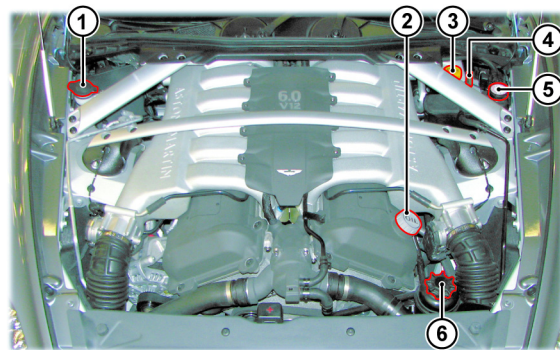

[1] - Washer fluid reservoir.

[2] - Engine oil filler cap.

[3] - Brake fluid reservoir<sup>1</sup>.

[4] - Engine oil dipstick.

[5] - Engine coolant reservoir.

[6] - Power steering fluid reservoir.

### Windscreen Wash Fluid Level

Top up as required. In winter, to prevent the windscreen wash fluid freezing, increase the fluid concentration (refer to the manufacturers recommendations on the windscreen wash fluid container).

When the level of windscreen wash fluid is low an information message will show in the message centre (right) and the amber warning symbol will come ON.



Local or state regulations may restrict the use of volatile organic compounds (VOCs), which are commonly used as antifreeze agents in windscreen washer fluid. A windscreen washer fluid with limited VOC content should be used only if it provides adequate freeze resistance for all regions and climates in which the vehicle will be operated.

### Windscreen Washer Jets

Washer jet housings are located on the rear edge of the bonnet. Each housing contains two washer jets.

Windscreen washer jets are set during manufacture and should not need adjustment. However, if adjustment is required, adjust up or down so that the fluid strikes between a third and half way up the windscreen.

### Brake Fluid Level

**⚠ Warning: Do not drive the vehicle if the brake fluid level is below the minimum mark.**

**⚠ Make sure that the brake fluid does not contact the paint work during the topping up operation. Serious paint work damage can result. If a spillage does occur, immediately flush any brake fluid from the paint work with clean, fresh water and then wipe with a clean damp cloth.**

Wipe the reservoir cap clean before removing to prevent ingress of contaminants.

The brake fluid level should read between the Min. and Max. marks.

1. Remove the reservoir cap. Top up to the Max. level.
2. Install the reservoir cap securely.

### Engine Coolant Level

**⚠ Warning: Do not remove the filler cap until the coolant system has cooled. Scalding can be caused by escaping steam or coolant.**

 Use a cloth or glove to protect hands and protect face and arms adequately.



<sup>1</sup>. Changes sides for left and right hand drive.

1. Remove the pressure cap to check the coolant level. The correct coolant level is to the top of the reservoir tank. Top up with the correct antifreeze mix, if required (Refer to 'Fluids and Capacities', page 12.9).
2. Make sure that the filler cap is secure after topping up.



**! Do not over tighten.**

If required to remove the pressure cap before the engine is cold, **use gloves or a protective cloth** and slowly loosen the pressure cap. Allow residual pressure to slowly drop. Continue to turn the pressure cap until it is released.

### Power Steering Fluid Level

**! Make sure that the power steering fluid does not contact the paint work during topping up. Serious paint work damage can result. If a spillage does occur, immediately flush any power steering fluid from the paint work with clean fresh water, then wipe with a clean damp cloth.**

Always check the reservoir level when the engine is cold and with the front road wheels in the straight ahead position.

Wipe the reservoir cap clean before removing to prevent an ingress of contaminants.

1. Remove the reservoir cap and wipe the dipstick clean with a lint free cloth. Replace and remove again. The fluid level should read between the Min. and Max. marks.
2. If required, top up fluid level. **Do not overfill.**

### Engine Oil Level

**! Warning: Engine oil or components may be hot and could cause severe burns.**

**! Running the engine with engine oil below the lower mark or above the upper mark can cause serious engine damage.**

**! This vehicle's warranty may be invalidated if damage is caused by the use of incorrect engine oil. Low quality or obsolete oils do NOT give the protection required by modern, high performance engines.**



**! Failure to use engine oil that meets the required specification could cause excessive engine wear, a build up of sludge and deposits, and increased pollution. It could also lead to engine failure (Refer to 'Fluids and Capacities', page 12.9).**

- The vehicle should be on level ground
- Check the oil level when the engine completely cold
- Check the engine oil level every fourth fuel tank fill or weekly - whichever ever is the sooner

### Oil level check:

1. Withdraw and wipe the dipstick clean, using a lint free cloth.



- Fully insert the dipstick with the Min. and Max. marking on the blade upwards (facing towards the engine). Withdraw again.

 *Approximately one litre (two pints) is required to bring the level from Min. to Max.*

- The oil level should read between the Min. & Max. marks.

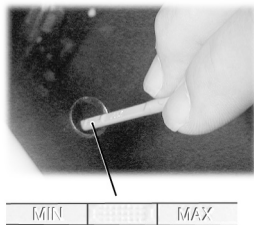
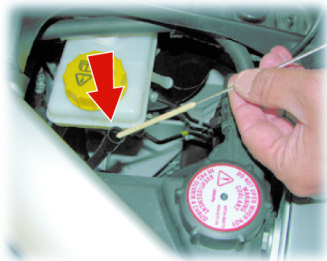

- If required remove the filler, top up to the Max. mark with the recommended engine oil.
- Wait for approximately two minutes for the oil to settle, then check the level again. Add oil if required. **Do not overfill.**
- Replace the filler cap securely, replace the dipstick & press it home.



## Windscreen Blade Replacement

To replace the windscreen wiper blades the wiper arms must be set at 90° to the vehicle (A).

- Press and hold in buttons 2 and 6 (Infotainment keypad). Insert the vehicle key in the ignition control and move to position 'II' (ignition ON). This will manoeuvre the wiper blade arms to the 90° position. Return the vehicle key to position '0'.
- Lift the wiper arm(s) up and remove the worn wiper blade(s). Install the new wiper blade(s) and lower the wiper arm(s).
- After replacing the wiper blade either:
  - Move the vehicle key back through to position 'II' to lower the wiper arms. Return the vehicle key to position '0' or remove
  - Operate the wiper stalk - the wiper arms will complete the request and then park

## Brake Pad 'Bedding-in'

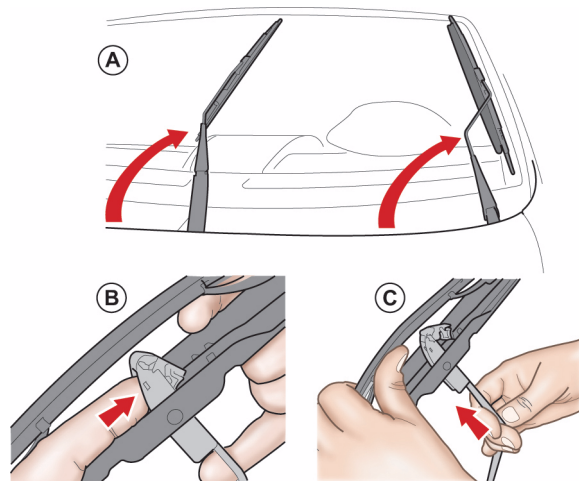

**!** *Failure to 'bed-in' new brake pads will result in reduced brake performance and possible brake judder or squeal.*

After the installation of new brake pads, brake performance will be reduced, as the brake discs and pads need to be 'Bedded-in'. For the first few hundred kilometres of new brake pad use, avoid excessive braking (hard stops from high speed, alpine descents, etc.).

## Tyres

Tyres of the correct type, manufacturer and dimensions, with correct cold inflation pressures are an integral part of every vehicle's design. Regular maintenance of tyres contributes not only to safety, but to the designed function of the vehicle.

Road holding, steering and braking are especially vulnerable to incorrectly pressurised, badly installed or worn tyres.

Tyres of the correct size and type, but of different make have widely varying characteristics.

Only install tyres approved by Aston Martin.

### Tyre Pressures

Make sure that correct tyre pressures are carefully maintained. Road holding, steering, braking and tyre wear are especially vulnerable to incorrect tyre pressures.

Check tyre pressures regularly and before starting any journey. Re-inflate any tyre with a low pressure at the earliest opportunity.

Pressures increase slightly when the tyres are hot. For an accurate reading, pressures should be checked when the tyres are cold. After adjusting the tyre pressures, make sure that the valve caps are securely replaced to provide an additional air seal and to prevent the ingress of dirt.

## Tyre Service

The recommended tyres for this vehicle are asymmetrical and must be installed to the wheel with the tyre mark 'Outside' on the outside of the wheel rim.

They are also of different sizes on the front and rear axles, therefore complete wheels cannot be swapped between axles. Complete wheels can, however, be swapped from side to side on the same axle.

 *Because of the high performance potential of this vehicle, Aston Martin strongly recommend replacement of any damaged or worn tyre.*

## Damage

Tyres should be examined at regular intervals for wear and damage. Inspect the tyre treads and sidewalls for damage, i.e. bulges in the tread or the sidewalls, cracks in the tread groove and separation in the tread or the sidewalls. If damage is observed or suspected have the tyre inspected by a tyre professional.

Stones or other objects which have become lodged in the tyre treads should be carefully removed.

## Flat Spots

It is a characteristic of high performance tyres that temporary 'flat spots' may develop if the vehicle is left standing in high or low ambient temperatures for any length of time.

These 'flat spots' will manifest themselves as minor vibrations when the vehicle is first driven from cold. As the tyres warm up to operating temperature, normal tyre shape should be restored and the vibrations cease. If vibrations persist, consult your Aston Martin Dealer.

## Age

Tyres degrade over time, even when they are not being used. It is recommended that tyres generally be replaced after five years of normal service. Heat caused by hot climates or frequent high loading conditions can accelerate the aging process.

 *Local regulations on tyre life may apply.*

## New Tyres

New tyres should not be installed to the front wheels in combination with worn rear tyres, as rear end stability will be affected. When new tyres are required consult your Aston Martin Dealer for advice if the rear tyres are also worn. Each wheel and tyre unit must be balanced dynamically and measured for Radial Force Variation (RFV)<sub>1</sub> to make sure of efficient steering, optimum tyre wear and maximum ride comfort. Because of the potentially high speeds, it is essential that wheel balancing is carried out when new tyres are installed.

## Running-In New Tyres

When new tyres have been installed, speed should be limited, particularly during the first 80 km or so of driving. Fast cornering, hard braking, and harsh acceleration should also be avoided during this period.

---

<sup>1</sup>. Contact your Aston Martin Dealer for more information.



### Tread Wear Marks

Tread wear marks (A) are incorporated into the construction of all tyres. These marks are integral moulded ribs spaced at regular intervals around the circumference of the tyre and extend across the full width of the tread, in all primary grooves.

When a tyre has worn causing one or more of the marks to be flush with the outer face of the tread the tyre has reached its wear limit. It then becomes illegal in certain countries and must be replaced.



### Winter Tyres

The tyres installed as original equipment are designed with a rubber compound, tread pattern and width specially suited for high speeds in normal road conditions, but they are less suitable during extremes of low temperatures, snow and ice. The use of winter tyres will considerably improve handling during these conditions.

Only use Aston Martin approved winter tyres.

**⚠ Warning: Maximum speed with winter tyres is 270 km/h.**

Winter tires must be used in vehicle sets, that is, installed on all four wheels. Do not exceed the tyre speed rating when using winter tyres. Contact your Aston Martin Dealer.

### Snow Chains

**⚠ Warning: The maximum speed when using snow chains is 48 km/h. Remove the snow chains immediately the roads are clear of snow**

These are available from your Aston Martin Dealer for temporary use when driving in heavy snow conditions. Snow chains should only be installed to the rear (driven) wheels.

 Make sure that the installation instructions supplied with the snow chains are kept in a safe place.

### Tyre Sealant Kit

**⚠ Warning: Do not use the system to seal a tyre that was damaged while driving with insufficient air pressure (e.g. tyre cuts, cracks, bumps or similar damage). Do not use the system to seal tyres with side wall damage. Only punctures in the tread area of tyres may be sealed.**

**⚠ Warning: Do not stand directly beside the tyre while the compressor is pumping. Watch the side wall of the tyre. If there are any cracks, bumps or similar damage set the compressor to OFF. The journey should not be continued. Contact your nearest Aston Martin Dealer.**

**⚠ Warning: If a tyre pressure of 1.8 bar cannot be reached then the tyre can not be sealed. Do not attempt to re-inflate the tyre. Contact your Aston Martin Dealer.**

**⚠ Warning: If the pressure in the tyre after driving for 3 km is below 1.3 bar the tyre has not been effectively sealed. The journey should not be continued. Contact your nearest Aston Martin Dealer.**

**⚠ Warning: After a longer period of rest, the tyre pressure should be rechecked.**

⚠ **The tyre sealant kit only provides temporary mobility. Always refer to local laws and regulations on the use and repair of tyres that have been treated with any form of temporary mobility aid. Consult a tyre specialist for advice.**

📖 Inform the tyre specialist that the tyre contains sealant.

### Location



### Operation

Remove the tyre sealant kit from its location in the boot. Follow the instructions detailed on the lid.

Read the following instructions and warnings carefully before using the tyre sealant kit. Compliance with these instructions is vital to make sure of vehicle and user safety. Noncompliance with these instructions means risking severe tyre damage and hazardous vehicle behaviour which can lead to a road accident involving damage to property or injury to persons.

- Make sure that the vehicle is parked far enough from traffic so that there is no danger from passing vehicles and so that you do not disrupt the traffic. Warn other vehicles using the warning triangle
- The system should only be used between temperatures of  $-40^{\circ}\text{C}$  and  $70^{\circ}\text{C}$
- A maximum speed of 80 km/h may not be exceeded at any time after sealing the tyre with the system
- The system provides only a **temporary emergency repair** for continuing the journey up to 200 km or to the nearest Aston Martin Dealer
- If the nearest Aston Martin Dealer is over a 200 km away arrange for collection under the Aston Martin Emergency Service scheme

- The system will effectively seal a tyre that was punctured by an object with a diameter of up to 6 mm. It is possible that a tyre, especially with greater damage, will not be sealed. Do not remove objects that punctured the tyre if they are still lodged in the tyre
- The sealant bottle needs to be exchanged before it expires. **Do not** use the system after the expiry date on the sealant bottle or casing has been reached. Contact your nearest Aston Martin Dealer
- Do not attempt to inflate other objects without using a system adapter and do not inflate objects with a volume greater than 50 litre (air mattresses, rubber boats, etc.). Do not let the system pump air for more than 10 minutes without stopping it and allowing it to cool down

Both the hose and the bottle of sealant need to be replaced after using the system. Sealant deposits in a used hose may cause the system to operate incorrectly. New bottles of sealant can be purchased from your Aston Martin Dealer.

Dispose of empty sealant bottles together with normal household waste.

Remains of liquid sealant must be handed over to your dealer or disposed of in compliance with local waste disposal regulations.

## Vehicle Recovery

⚠ **When moving the vehicle by transporter make sure that the vehicle is not strapped down to the transporter by the suspension control arms.**

⚠ **Power braking and power steering are not available with the engine OFF. Substantially higher brake pedal pressures and steering effort are required.**

⚠ **If there is a transmission fault, this vehicle must be transported.**

Your vehicle should always be recovered on a vehicle transporter<sup>1</sup> and should only be towed for **short distances**, for example, if it is causing an obstruction or if it requires winching onto a transporter.

If the park brake was applied and the vehicle has lost power, the park brake will not release. Call Aston Martin assistance.

If moving the vehicle in such a situation:

<sup>1</sup> The recommended method for a recovering vehicle is to have it transported in a purpose built, covered, vehicle transporter.

1. Remove the towing eye from its storage location in the vehicle tool kit. Use the screwdriver to remove the front registration plate, then install the towing eye to the exposed female threads (A)<sup>2</sup>.

Protect vehicle paint work when installing the towing eye.

2. If possible put the transmission into neutral. If the transmission has gone into parklock operate the parklock override lever. Move the vehicle key to position 'II' (ignition ON) to release the steering lock.
3. When being towed use the footbrake very gently as required to prevent excessive slack in the tow rope.

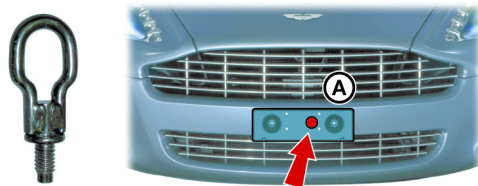

<sup>2</sup> The towing eye has a left hand thread.

## Parklock Override

⚠ **If the vehicle has power - apply the park brake before operating the parklock override lever. If the vehicle has no power - make sure that at least one wheel is prevented from moving, for example, by placing a chock (block of wood, large stone, etc.) at the front and rear of the tyre. There is the danger that the vehicle will roll, depending on the incline of the road.**

⚠ **The warning message, GEARBOX FAULT, PARKLOCK FAILURE, in the message centre (right) must go OFF and the GPID must change from N to P. Otherwise there is the danger that the vehicle will roll away.**

If the vehicle fails to start or has broken down the automatic transmission will move into P (park). To tow or move the vehicle use the parklock override lever to manually unlock the automatic transmission parklock.

If the park brake was applied and the vehicle has lost power, the park brake will not release. Call Aston Martin assistance.

## Operating the Parklock Override

Make sure that the vehicle can not roll, apply the park brake (power available) or make sure that at least one wheel is prevented from moving, for example, by placing a chock (block of wood, large stone, etc.) at the front and rear of the tyre.

In the rear left passenger footwell (A) lift the floor carpet where it meets the heel board, to show the two screws holding the heel board trim in place. Remove the two screws. Raise the heel board trim panel to access the parklock override lever.

Pull the parklock override lever (B) fully up on the ratchet, fully releasing the parklock.

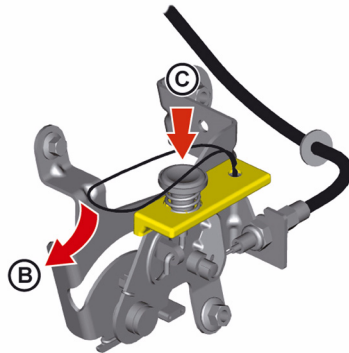

After towing or moving make sure that the vehicle can not roll. Lift the parklock override lever slightly and press the ratchet release button (C). With the ratchet release button pressed lower the parklock override lever back to the stop. The parklock is now locked.

## Battery Disconnect Switch

**!** *Before the battery disconnect switch is pressed make sure that all door windows have dropped (open a left and right side door). If the windows have not dropped before the power is disconnected they may damage the door seals when a door is opened. The door windows must be reset once the battery connect switch has been pressed (Refer to 'Door Window Reset', page 11.30).*

Your vehicle has a Battery Disconnect Switch (BDS) and a Battery Connect Switch (BCS). For transportation it will be necessary for the recovery operator to disconnect the vehicle battery.

Before the BDS or the BCS is pressed make sure the vehicle key is removed from the ignition control.

Remove the two screws that secure the heel board carpet trim panel in the rear left passenger footwell (C). Raise the heel board trim pane to access the two switches. To set all vehicle electrics to OFF press the BDS (A). To set the electrical systems ON press the BCS (B).



### Front Seat Reset

If the vehicle key is not removed from the ignition control before the BDS is pressed and a front seat(s) have been adjusted at the start of the journey, the front seats may need to be reset. To reset a front seat:

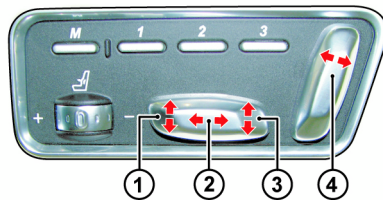

1. Press the seat forward button (2) until the seat is fully forward.
2. Press the seat back button (4) until the seat back is fully backwards.
3. Press the seat down button (1) until the front of the seat is fully down.
4. Press the seat down button (3) until the rear of the seat is fully down.

### Jump Start From Another Vehicle

**⚠ Warning: The donor vehicle must have a 12 volt battery and a negative (-), black earth terminal to make sure that the correct battery polarity is maintained.**

**⚠ Apart from vehicle recovery, this vehicle must not be driven if the vehicle battery is incapable of starting the engine. In this case the vehicle battery must be replaced.**

**⚠ If the voltage or earth of the donor vehicle is different or not known, do not attempt starting in the way described.**

If this vehicle will not start due to a discharged battery, it may be started, **for vehicle recovery**, by connecting the battery from another vehicle (donor) to this vehicle (recipient).

### Jump Start Procedure

**⚠ Remove rings, metal watch bands and any other jewellery.**

**⚠ Set all electrical motors and ancillaries in both vehicles to OFF.**

**⚠ Set all lamps to OFF except those needed to protect vehicles or illuminate the work area.**

1. Position the vehicles so that the connecting cables will reach into the recipient engine bay. Apply the park brake and set the ignition to OFF.
2. Access the jump start terminal in the **recipient** engine bay.

- Connect the +ve (red) cable between the '+ve' (red) terminal of the donor battery and the jump start terminal of the **recipient** vehicle.

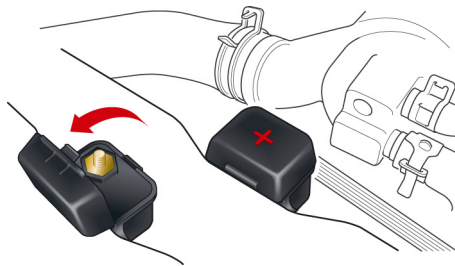



- Connect the '-ve' (black) cable between the '-ve' (black) terminal of the donor battery and a good earth (-ve) point in the recipient engine bay (i.e. alternator mounting bracket).
- Start the donor vehicle engine and run at about 1500 – 2000 rpm.
- Start the engine of the recipient vehicle.

- Once both vehicles are running remove the jump start cables (first the '-ve' (black) cable from both vehicles and then the '+ve' (red) cable from both vehicles).

Allow the recipient engine to run until the discharged battery is sufficiently recharged (15 to 20 minutes) to start the engine without assistance. Set to OFF and restart the recipient engine. Take the vehicle on a long run to fully charge the battery.

Contact your Aston Martin Dealer to have the battery checked or replaced.

 Recharge time will depend on the initial 'state of health' of discharged battery.

 If this vehicle will not start consult your Aston Martin Dealer.

## Vehicle Battery

 **Warning: Battery posts, terminals and related accessories contain lead and lead compounds. Wash hands after handling.**

 **Warning: Do not allow flames, sparks or lighted substances to come near the battery. Batteries normally produce explosive gases which can cause personal injury. When working near the battery, always shield your face and protect your eyes. Always have sufficient ventilation.**

 **Warning: When lifting a plastic cased battery, excessive pressure on the end walls could cause acid to flow through the vent caps, resulting in personal injury, damage to the vehicle or battery. Lift the battery with a battery carrier or with your hands on opposite corners.**

 **Warning: Keep batteries out of reach of children.**

 **Warning: Batteries contain sulphuric acid. Avoid contact with skin, eyes or clothing. Shield your eyes when working near the battery to protect against possible splashing of acid solution. In case of acid contact with skin or eyes, flush immediately with water for a minimum of 15 minutes and get prompt medical attention. If acid is swallowed, get medical help immediately.**

⚠ *The engine must never be run with the vehicle battery disconnected.*

⚠ *Apart from vehicle recovery, this vehicle must not be driven if the vehicle battery is incapable of starting the engine. In this case the vehicle battery must be replaced. Contact your Aston Martin Dealer.*

The vehicle battery is located under the rear right seat. It is maintenance free and should only require checking by your Aston Martin Dealer during regular vehicle services.

### Vehicle Battery Disposal

It is the responsibility of the vehicle owner when disposing of automotive batteries to do it in an environmentally correct manner.

The incorrect disposal of a vehicle (lead-acid) battery can be extremely hazardous to health and the environment. Most batteries contain heavy metals and when disposed of incorrectly, these heavy metals may leak into the ground. This can contribute to soil and water pollution and endanger wildlife.

Follow your local authorised standards for disposal. Call your local authorised recycling centre to find out more about recycling automotive batteries.

Do not dispose of your vehicle battery in the household waste.

### Warnings

The following warnings are located on the vehicle battery.





## Vehicle Battery Charge

Various systems, for example, the clock, security systems and Infotainment centre system continue to drain battery power even with the ignition OFF.

A **new fully charged** battery has the ability to start this vehicle, if left unused, for up to 45 days without a battery conditioner being used.

 *In cold climates this time may be reduced.*

 *For vehicles installed with the Aston Martin Tracking system this time will reduce to approximately 22 days.*

 *Aston Martin recommend that if this vehicle is to be left unused for ten (10) days or more a battery conditioner (mains power available) should be used.*

Battery charge can be drained excessively in a number of ways:

- If the vehicle is unused for long periods of time
- If the vehicle is used regularly but only for short journeys, e.g. less than 48 km a journey
- If electrical systems are in use without the vehicle engine running
- If the vehicle key is left in the ignition control for long periods of time without the engine operating

Excessive battery drain would ultimately mean that the battery would not be able to start the engine.

## Battery Conditioner

(Option)

 **Warning: Do not attempt to start the vehicle with a battery conditioner connected to the mains supply.**

 **Warning: Do not smoke. Prevent flames and sparks. Explosive gasses are given off by batteries during charging.**

 **A battery conditioner is designed for conditioning of partially or fully charged batteries. It will not effectively charge a discharged battery.**

 **For indoor use only. Disconnect mains supply before making or breaking battery connections.**

 *The battery conditioner supplied with the vehicle is suitable for use on all types of 12 volt lead acid batteries.*

If this vehicle is not going to be used for a period of time, and **mains power is available**, use a battery conditioner to maintain the battery charge level.

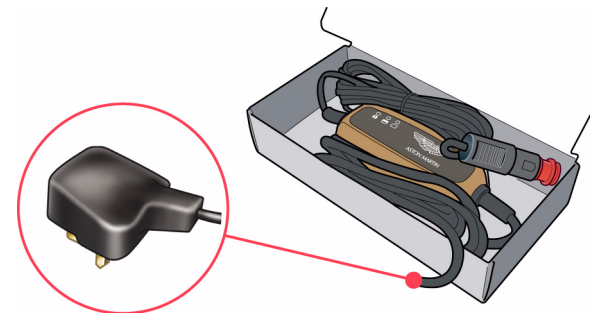

When connected the battery conditioner will maintain a small trickle charge to keep the battery in a fully charged state. The battery conditioner may be left in this state indefinitely.

### To Connect a Battery Conditioner

1. Insert the accessory socket plug (B) into the accessory socket (A (located in the boot right side)).
2. Insert the mains plug (C) into the mains supply.



Gently close, but do not latch, the boot lid. This avoids possible damage to the boot lid water seal from the battery conditioner power cable.

 With the boot lid left open the vehicle doors can be locked and armed.

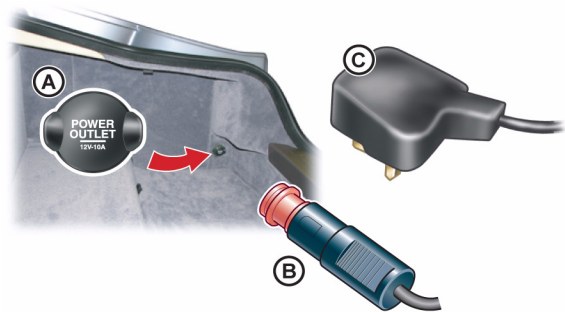

To remove the battery conditioner first disconnect from the mains supply, then from the vehicle socket.

## Battery Protection Mode

 **Replace the battery as soon as possible, if the battery is not capable of starting the engine.**

Using the vehicle electrical systems, i.e. the infotainment system, with the vehicle key at position '1' (ignition OFF) will drain the battery charge. Eventually the battery will drain to such a low level that it will not start the engine.

To avoid this happening, a series of safety mechanisms shut down nonessential electrical systems before excessive battery drain takes place.

### FAQ

**What is the first sign of battery protection mode?**

[A] - WARNING - LOW BATTERY (For 10 seconds).

[B] - LOW BATTERY

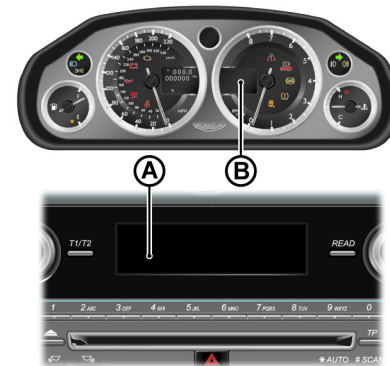

### What should I do next?

Set all unnecessary electrical systems to OFF to reduce battery drain. Start the engine to recharge the battery. Run the engine for a reasonable length of time.

**What happens if I ignore the warning messages?**

After approximately two to ten minutes (dependent on the rate of battery charge drain) the following messages will show:

**[A] - INFOTAINMENT WILL BE SHUT DOWN 2 MINUTES** (For 10 seconds).

**[B] - LOW BATTERY POWER SAVE.**

If the audio system is ON the sound will mute for 10 seconds and a short 'Beep' will be heard when the message is first shown.

**What should I do if these messages are shown?**

Set all unnecessary electrical systems to OFF. Start the engine to recharge the battery. Run the engine for a reasonable length of time.

**What happens if I ignore second warning messages?**

The infotainment system will shut down in two minutes. No other electrical system will be shut down. This significantly reduces the rate of battery drain. The following functionality will be lost:

- CD Player
- Navigation System
- Radio Tuner

**What should I do if the infotainment system shuts down?**

Start the engine to recharge the battery. Run the engine for a reasonable length of time.

The infotainment system will not operate without the engine running until the battery has regained its charge. With the engine running the infotainment system will start up.

**What is a reasonable length of time to run the engine?**

The vehicle battery normally requires a journey of approximately 48 km to recharge. Additionally, use the battery conditioner to restore the vehicle battery charge.

**What if I cannot restart the engine?**

If the battery has been run down to a point where it will not start the engine then an external battery charger<sup>1</sup> will be required or your vehicle will require a 'jump start' (Refer to 'Jump Start From Another Vehicle', page 11.17).

<sup>1</sup> A battery conditioner is designed for conditioning of partially or fully charged batteries. It will not effectively charge a discharged battery.

**Fuse Boxes**

The electrical system is protected by fuses. If any lamps, accessories, or controls don't work, inspect the appropriate circuit protector.

If a fuse has blown, the inside element will be melted. If the same fuse blows again, avoid using that system and consult your Aston Martin Dealer as soon as possible.

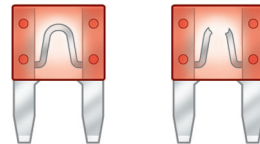

## Fuse Box Location

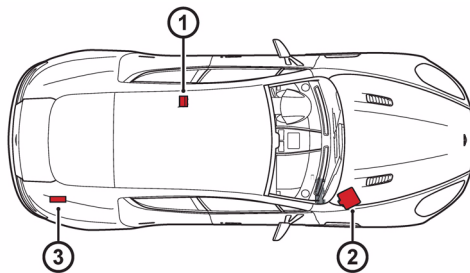

**[1]** - Cabin fuse box (rear left passenger footwell).

**[2]** - Engine bay fuse box (passenger side).

**[3]** - Boot fuse box.

## Fuses

### Engine Bay Fuses

Fuse	Rating	Function
F1	10A	ECU B keep alive power
F2	10A	Not available
F3	10	Not available
F4	20A	ECU A
F5	20A	ECU B
F6	15A	Heated oxygen and catalyst sensors (front and rear, bank B)
F7	15A	Ignition coils 7 to 12 (bank B)
F8	10A	Engine coolant sensor
F9	20A	Injectors 7 to 12 (bank B) / MAF sensor
F10	10A	Air conditioner compressor clutch

**Engine Bay Fuses**

<b>Fuse</b>	<b>Rating</b>	<b>Function</b>
F11	15A	Horns
F12	10A	ECU A keep alive power
F13	20A	Injectors 1 to 6 (bank A) / MAF sensor / Oil level sensor
F14	10A	Vapour management valve
F15	25A	Starter motor solenoid
F16	15A	Ignition coils 1 to 6 (bank A)
F17	15A	Not available
F18	15A	Heated oxygen and catalyst sensors (front and rear, bank A)
F19	40A	ABS Module
F20	20A	ABS Module
F21	30A	Not available

**Engine Bay Fuses**

<b>Fuse</b>	<b>Rating</b>	<b>Function</b>
F22	5A	Not available
F23		
F24	5A	Not available
F25	5A	Not available
F26	20A	Headlamp wash pump
F27	25A	Not available
F28	10A	ABS Module / Steering angle sensor / Vehicle key reader
F29	25A	Not available
F30	5A	ABS Module
F31	30A	Not available
F32	30A	Windscreen motor (slow)

---

---

**Engine Bay Fuses**

---

<b>Fuse</b>	<b>Rating</b>	<b>Function</b>
F33	30A	Windscreen motor (Fast)
F34	15A	Electric steering column lock
F35	80A	Cooling fan

---

---

**Cabin Fuses**

---

<b>Fuse</b>	<b>Rating</b>	<b>Function</b>
F1	5A	Aston Martin tracker keep alive power
F2	30A	Electric park brake module (+VE motor (RH))
F3	15A	Vacuum pump / Exhaust bypass valve
F4	10A	Front centre console switches
F5	30A	Electric park brake module (+VE motor (LH))
F6	10A	Rear centre console switches
F7	5A	Electric park brake module

**Cabin Fuses**

<b>Fuse</b>	<b>Rating</b>	<b>Function</b>
F8	30A	FPDM B module
F9	30A	FPDM A module
F10	25A	Rear left door module
F11	10A	Rear accessory socket
F12	20A	Adaptive damping module
F13	10A	Rear left footwell LED / Rear accessory socket illumination / Front and rear left boot LEDs / Rear left seat back release switch / Front left and right footwell LEDs / Rear left interior LED / Rear left and right header LEDs / Front header LED
F14	10A	Front centre console switches
F15	10A	Centre stack switches
F16	25A	Rear left accessory socket
F17	15A	Rear blower speed regulator
F18	30A	Not available

**Cabin Fuses**

<b>Fuse</b>	<b>Rating</b>	<b>Function</b>
F19	5A	Multi media module
F20	5A	Adaptive damping module
F21	25A	Front left door module
F22	5A	Parking assist module

**Boot Fuses**

<b>Fuse</b>	<b>Rating</b>	<b>Function</b>
F1	5A	Not available
F2	20A	Automatic transmission module
F3	30A	Heated rear windscreen
F4	20A	Wireless headphones transmitter and module
F5	30A	Audio amplifier / Audio power
F6	5A	Audio amplifier / MOST (wake up)
F7	5A	Rear seat entertainment module
F8	10A	Rear left seat back release
F9	10A	Rear right seat back release
F10	25A	Rear right door module
F11	5A	Not available

**Boot Fuses**

<b>Fuse</b>	<b>Rating</b>	<b>Function</b>
F12	10A	Not available
F13	15A	Not available
F14	5A	Rear right interior lamp / Front right and left boot lamp / Rear accessory socket illumination / Rear right seat back release switch
F15	5A	Rear footwell lamp / Boot lamp
F16	25A	Rear accessory socket
F17	5A	Battery disconnect switch
F18	30A	Audio amplifier / MOST [B+]
F19	5A	DVD changer module / Satellite radio tuner
F20	15A	Rear right seat heater
F21	25A	Front right door module
F22	15A	Rear left seat heater

## Headlamp Bulb

**⚠ Warning: High Intensity Discharge (HID) bulbs produce a very high voltage. They should only be serviced by an Aston Martin Dealership.**

**📖 Headlamp Units: Condensation:** The headlamp units will generate condensation under certain conditions. However, this should clear after approximately 10 minutes.

High Intensity Discharge (HID) bulbs are used for the combined main and dipped beam.

HID systems produce a brilliant white light by establishing a high voltage electrical arc between two electrodes within a sealed glass tube. Once the arc is established, the voltage lowers to normal operating conditions.

**HID bulbs are not renewable.** Contact to your Aston Martin Dealer if a HID bulb fails to operate.

## Other External Bulbs

### Front Indicator and Parking Lamps

If a front indicator or parking bulb fails to operate, contact your Aston Martin Dealer.

### Side Indicators

The side indicators comprise of five LEDs in each front wing side strake and are not repairable.

If a side indicator LED fails contact your Aston Martin Dealer.

**📖 LEDs can last tens of thousands of hours and are resistant to heat, cold, shock and vibration.**

### Registration Plate Lamps

1. Take care not to damage the vehicle trim. Use a small flat blade screwdriver to lever out, from the right side, the lens unit.
2. Twist, counterclockwise, and withdraw the bulb holder. Remove the defective bulb and replace with a new one.

3. Twist the bulb holder back into in position. Replace the boot trim panel.

### Rear Lamp Clusters

The rear indicators, stop and tail, reversing lamps and rear fog LEDs are contained in a sealed lamp cluster unit, one either side of the vehicle. The lamp cluster is not repairable, if a rear lamp fails contact your Aston Martin Dealer.

**📖 LEDs can last tens of thousands of hours and are resistant to heat, cold, shock and vibration.**

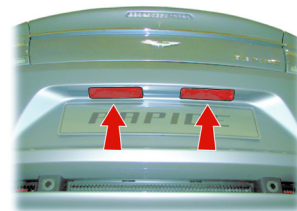



## Boot Lamps

The boot illumination comprises of four LEDs, two each side of the boot area and are not repairable.

If a boot LED fails contact your Aston Martin Dealer.

 LEDs can last tens of thousands of hours and are resistant to heat, cold, shock and vibration.

## Internal Lamps

The puddle lamps on each door and the front and rear footwell lamps are bulbs which can be renewed. All other internal lamps are LEDs.

 LEDs can last tens of thousands of hours and are resistant to heat, cold, shock and vibration.

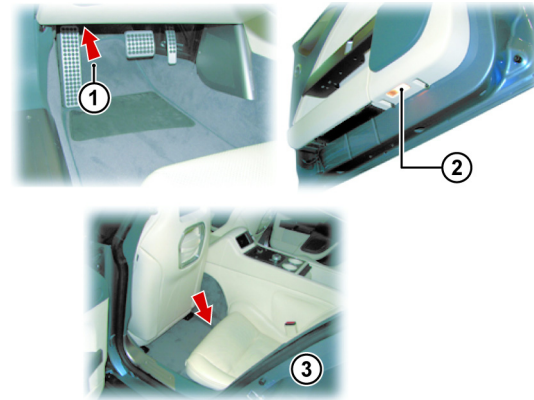

- [1] - Front footwell lamps
- [2] - Rear footwell lamps
- [3] - Door puddle lamps
- [4] - Front reading lamps
- [5] - Rear reading lamps

To renew a bulb:

1. Take care not to damage the vehicle trim, lever out the lens unit.
2. Replace the defective bulb.

**Door lamp only:** Open the access flap and replace the defective bulb.

## Tourist Headlamp Adjustment

- Press the lens unit into its housing until it clips into position.

The headlamp beams can be adjusted to give a flat beam. This prevents dazzling oncoming vehicles if driving in another country where the road priority changes, i.e. from driving on the right to driving on the left.

Remove the panel in each wheel arch liner. Turn the steering to the opposite lock from the headlamp unit. Using a flat blade, i.e. a screwdriver or a small coin, release the screw on the access panel and remove the panel.



Remove the rubber cap and locate the headlamp adjust lever (A). Move the lever down to give a flat headlamp beam. Install the rubber cap and the wheel arch liner panel. Repeat for the other headlamp.

Remember to set the adjustment level back to normal beam (lever up) when back in your home country.

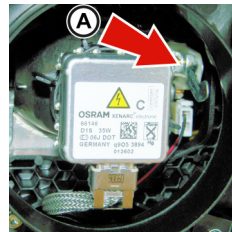

## Door Window Reset

If power to the electric windows has been interrupted for any reason, they will fail to operate correctly until reset.

- Sit in the driver's seat with all doors closed, insert the vehicle key into the ignition control and move to position 'II' (ignition ON).
- Press firmly and hold the window switch until the window is at the maximum down position. Continue to hold the button for five seconds then release.
- Pull back and hold the window switch until the window is in the maximum up position. Continue to hold the switch for a further five seconds, then release.
- The window is now reset. Repeat for the other door windows.

## Front Seat Reset

Should the either front seat fail to move rearward or the seat memory position fails to work this may show a loss of seat position in the vehicle's memory. If so, complete the seat reset procedure detailed below:

**⚠ Warning: Make sure that there is nothing in front of, behind, or under the seat during adjustment.**

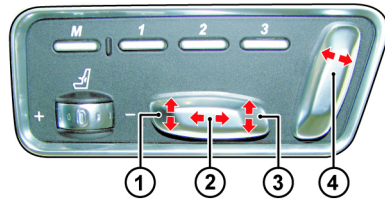

1. Press the seat forward button (2) until the seat is fully forward.
2. Press the seat back button (4) until the seat back is fully backwards.
3. Press the seat down button (1) until the front of the seat is fully down.

4. Press the seat down button (3) until the rear of the seat is fully down.

The seat movement and position memory should now work correctly, if not contact your Aston Martin Dealer.

## Bodywork Maintenance

### Door drain holes

Check the drain holes in the bottom face of each door periodically and clear if necessary with, for example, a short length of wire or a pipe cleaner.

## Paint Work

Modern water based paints are much safer and more environmentally friendly than solvent based paints. Water based paints are however more susceptible to contamination and marking by corrosive substances. The following list is not exhaustive but does show the most common contaminants which may adversely affect your paint work:

 Other groups of contaminants may be added to this list as experience of water based paints and finishes increases.

- Bird Droppings
- Antifreeze
- Tree Sap
- Oils and Greases
- Insect Remains

Wash such substances from the vehicle using clean warm water with vehicle shampoo, at the earliest opportunity, especially in sunny weather which can accelerate contamination.

## Washing

 **Warning: Washing and polishing agents containing silicone should not be applied to glass. This will reduce the efficiency of the windscreen wipers, causing smears which will reduce visibility, particularly during darkness and in the rain.**

 **Commercially operated automatic vehicle washes, jet washes and power operated mops are not recommended. The detergents used can contain certain chemicals which may, over time, be detrimental to some exterior parts of the vehicle. Prolonged usage of automatic vehicle washes and power operated mops will also cause fine scratches in the paint surface.**

For best results, do not wash the vehicle in strong sunlight. Allow the vehicle to cool before washing. Do not use household soaps or detergents. Do not direct water hoses at full force around the door and boot lid seals.

When washing the vehicle, first hose it down first to remove all dust and mud residue.

When dust and mud have been removed wash gently with a soft sponge using cold or warm water with a mild neutral detergent as directed by the detergent manufacturer. Rinse thoroughly with a hose to remove all traces of soapy water. Finally dry with a chamois leather, which should be rinsed regularly in clean water.

Wash and clean the vehicle's front grill in the same way as the paint work, but make sure that the front grill is dried off completely leaving no water droplets on the grill (wipe the front grill last using a chamois leather): Chrome polish or other abrasive cleaners must not be used.

Aston Martin recommends the use of AUTOGLYM vehicle care products or preparations of similar reputable manufacture for adding to the washing water. Make sure that the manufacture's instructions are followed.

During the winter months, it is advisable to wash the vehicle more frequently, paying particular attention to the underside to combat the detrimental effects of any salt and sand contamination picked up from treated roads.

To delay the onset of corrosion developing on the brake components Aston Martin recommend that after washing this vehicle, the vehicle should be driven a short distance to make sure that all the water and washing product has dried off.

### Road Wheels

To avoid possible damage to the alloy road wheels, wheel nuts & wheel centre trims, from a build up of brake dust wash and clean the alloy road wheels frequently, using a mild soapy water solution only. Do not use chemical alloy road wheel cleaners, as they can often have a high acid or alkaline content and could cause discolouration. Always clean one wheel at a time and do not allow the cleaning solution to dry on the wheel. Fully flush off with clean water.

### Headlamp Lenses

Only use a mild soapy water solution when washing the Headlamp Lenses. Do not use cleaning materials which contain solvents.

Cleaning materials which contain solvents, i.e. tar remover, petrol, waxes or polishes, may damage the headlamp lens.

### Polishing

Approximately twice a year, a good quality polish should be applied to the body work and then buffed, using a soft lint free cloth.

The alloy wheel rims should be treated with a cleaner which is specifically manufactured for this purpose.

### Upholstery, Carpets and Seats

**⚠ Warning: Fumes from cleaning solvents may be dangerous in confined spaces. Make sure that the vehicle is well ventilated and follow the manufacturer's printed instructions when using these products.**

The seats and soft trimmed components of this vehicle are covered in natural leather hide.

In general, this natural leather upholstery requires little attention. The seats should be brushed with a soft brush from time to time and may be cleaned occasionally with a cloth damped in soap and water.

**Do not** use detergents, quick cleansers or furniture polishes.

Several times a year, a leather conditioner or preservative should be used. Appropriate care materials are obtainable from your Aston Martin Dealer.

Alcantara roof linings and other soft trimmed areas may be brushed with a soft brush. Stains from water based substances such as coffee, tea or soft drinks should be cleaned as soon as possible with mild soap and water.

Consult your Aston Martin Dealer for instructions on the removal of more difficult stains such as oil, grease or ballpoint ink.

Carpets should be cleaned regularly with a vacuum cleaner. Any stains or grease marks should be removed with a good quality solvent suitable for use on carpets.

### Care and Maintenance of Seat Belts

**⚠ Do not allow seat belts to be retracted until they are completely dry.**

To make sure that the restraint webbings are in correct working order, regularly check the seat belts. Look for fraying, cuts, burns and similar problems. Make sure that the latches and buckles operate correctly. If a seat belt is not in good condition or is not working correctly, consult your Aston Martin Dealer.

Any seat belt that has been worn during a serious collision should be replaced by an Aston Martin Dealer.

To clean the seat belts, use mild soap and water; do not use bleach, solvents or dyes as they can weaken the material. Allow the seat belts to dry thoroughly before use.

## Under Bonnet Cleaning

Under bonnet cleaning using high pressure hoses or steam cleaners should not be carried out. The electronic control module connections and fuse boxes can be damaged by indiscriminate use of high pressure cleaning equipment.

## Vehicle Storage

### Recommendations

 *These recommendations apply to new and pre-owned vehicles either in dealer or customer ownership.*

If your vehicle is not to be used for periods in excess of three months it should be stored in a dry, well ventilated building.

1. Drive the vehicle for a sufficient distance to warm the oil in the engine and the transaxle; make sure that the internal components of the engine are lubricated.
2. Check the engine coolant level. Top up if necessary with the correct antifreeze and water solution.
3. In order to take the weight off the tyres, raise the vehicle with a jack and place supports under the front and rear suspension.
4. If the vehicle is not raised from the ground, increase the tyre pressures to 3.4 bar. Cover the tyres to exclude any light. Turn the wheels  $\frac{1}{4}$  turn every month to avoid tyre flat spots.
5. If mains power is available, use a battery conditioner to maintain the battery in a fully charged state.
6. Once a month:
  - 6.1 Disconnect the battery conditioner (if installed).
  - 6.2 Start and operate the engine until it is fully warmed up.

- 6.3 Check there are no fluid leaks.
- 6.4 Set the ignition to OFF.
- 6.5 Connect the battery conditioner.
- 6.6 Check and correct tyre pressures if necessary.  
When returning the vehicle to normal service, set the tyre pressures to normal specification before driving on the road.

### Extended Storage

For storage periods exceeding six months the following measures are recommended:

 *Do Not Drain Fuel System.*

1. Operate the engine until there is as small a quantity of fuel in the tank as is practical for storage purposes.
2. Add engine oil to the remaining fuel in the tank to make a concentration of 2% (i.e. 20 ml per one ltr of fuel), then operate engine for not less than ten minutes to circulate the mixture thoroughly through all of the fuel system.
3. Inspect rubber connections of coolant system and have them renewed if necessary.

4. Wash the vehicle bodywork thoroughly and repair any paint blisters or patches of corrosion in order to prevent any further deterioration. Apply a suitable polish.
5. Clean the carpets and upholstery thoroughly. Treat all leather upholstery with an application of a leather conditioner or preservative.
6. If the storage building is dry leave vehicle windows slightly open. If there is any tendency towards dampness close vehicle doors and windows and place an anti-moisture compound such as silica desiccant bags in an open metal container inside vehicle.
7. Cover vehicle with a cotton or fabric cover.

### Recommissioning after Storage

Provided that the vehicle has been stored in accordance with the recommended procedure, only the following points should need attention before using your vehicle on the road.

***⚠ Starting the engine without sufficient lubrication can cause serious engine damage. Make sure that the engine oil pressure is established before the engine starts.***

1. Check the tyre pressures, inflate if necessary, lower the vehicle to ground.

2. Drain the engine oil and install a new engine oil filter element. Fill the engine to its maximum level (as shown on the dip stick) with approved oil.
3. Drain the final drive unit. Fill the final drive unit to its maximum level (oil will dribble out of the fill hole), with approved oil.
4. Check the coolant level and, if necessary, top up with the correct antifreeze to water solution.
5. Check all fluid levels and top up as necessary.
6. Fill the fuel tank.
7. Obtain engine oil pressure:
  - 7.1 Press and hold the accelerator pedal hard to the floor (this temporarily stops fuel injection during cranking).
  - 7.2 Fully press the brake pedal down. Insert the vehicle key into the ignition control and move through to engine start. Let the engine to crank until the oil pressure symbol  (in the instrument cluster) goes OFF (oil pressure in the engine).
  - 7.3 Set the ignition to OFF. Release the vehicle key and accelerator pedal.
8. Start the engine normally and check that the oil pressure and ignition warning symbols go OFF as the engine starts (correct oil pressure and battery charging).

9. Raise the bonnet and check for leaks of fuel, oil and coolant.
10. Carefully test drive your vehicle and check the operation of all functions.

Braking performance can be impaired, initially, due to a fine film of corrosion on the brake disc surface. Drive conservatively and, when safe to do so, frequently apply the brakes until disc surfaces have been cleaned. Full braking performance should then be restored.

If in any doubt about the condition of your vehicle, have it checked by your Aston Martin Dealer.



ASTON MARTIN



ASTON MARTIN



ASTON MARTIN



# Specifications

Engine.....	12.2	Wheels .....	12.4
Performance .....	12.2	Tyres.....	12.5
Power and Torque .....	12.2	Bulbs .....	12.6
Transmission .....	12.3	Vehicle Specification.....	12.6
Electrics.....	12.3	Vehicle Weights .....	12.6
Steering.....	12.3	Vehicle Dimensions .....	12.7
Suspension.....	12.4	Vehicle Features.....	12.8
Brakes.....	12.4	Fluids and Capacities .....	12.9

## Engine

All alloy, quad overhead cam 48 valve V12

**Fuel** - Recommended 98 RON Super Unleaded for optimum performance. 95 RON minimum.

**Fuel Delivery System** - Multi point sequential fuel injection.

**Capacity** - 5935 cc

**Firing Order** - 1 - 7 - 5 - 11 - 3 - 9 - 6 - 12 - 2 - 8 - 4 - 10

**Idle Speed** - 650 rpm

**Bore** - 89.0 mm

**Stroke** - 79.5 mm

**Spark Plugs** - NGK – PTR6E-13

**Spark Plug Gap** - 1.3 mm  $\pm$  0.1 mm

**Compression Ratio** - 10.7:1

**Ignition** - 'Coil on Plug' ignition system

**Emission Control** - Eight Oxygen sensors (four per exhaust branch).

Two three-way catalytic convertors (one per exhaust branch).

Evaporative loss purge

**Lubrication** - Wet sump pressurised lubrication

## Performance

**Maximum Power** - 350.5 kw @ 6000 rpm

**Maximum Torque** - 600.0 Nm @ 5000 rpm

**Maximum Speed** - 296.0 km/h<sub>1</sub>

**0-100 km/h** - 5.2 seconds

**Maximum Engine Speed** - 6850.0 rpm

## Power and Torque

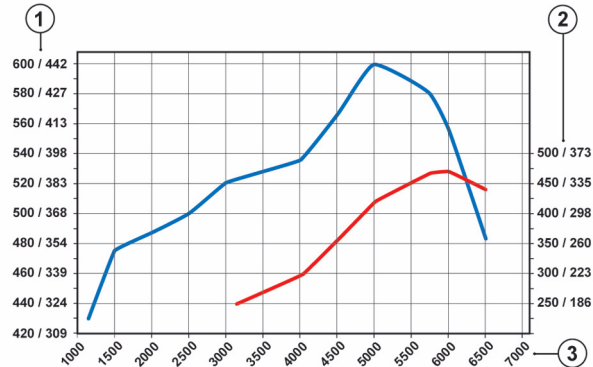

[1] - Torque (Nm / lb/ft)

[2] - Power (kw / bhp)

[3] - Engine speed (rpm)

<sub>1</sub>. Where permitted.

## Transmission

### Automatic Transmission

ZF 6HP26 six speed with 'Shift by Wire' (SBW) gear shift technology.

### Gear Ratios

1st	4.17:1
2nd	2.34:1
3rd	1.52:1
4th	1.14:1
5th	0.87:1
6th	0.69:1
Reverse	3.40:1

**Final Drive** - Ratio - 3.49:1. Limited slip differential

## Electrics

**Alternator** - Denso SC5 200 Amps

**Voltage Regulation** - 14.4V  $\pm$ 0.5V @ 20°C

**Battery** - Banner 88 AH

## Steering

Rack and pinion, servotronic speed sensitive power assisted steering. Column tilt and reach adjustments.

**Turns lock to lock** - 2.75

**Turning Circle** - 12.5 m (Kerb to Kerb)

**Toe<sub>1</sub>** -

### Front Toe Out (Total)

0.13° ( $\pm$  0.07°)  
(8' ( $\pm$ 4'))

### Rear Toe Out (Total)

0.33° (+0.17° / -0.0°)  
(20' (+10' / -0.0'))

<sup>1</sup>. With the vehicle at its Design Weight. Refer to your Aston Martin Dealer.

## Suspension

**Front** - Aluminium independent double wishbone incorporating anti-dive geometry. Coil over aluminium monotube dampers and anti-roll bar.

**Rear** - Aluminium independent double wishbone incorporating longitudinal control arms. Coil over aluminium monotube dampers and anti-roll bar.

### Features

- Dynamic Stability Control (DSC)
- Adaptive damping system (ADS)

## Brakes

### Footbrake

#### Dual Cast Ventilated Discs

	Front	Rear
Diameter	390 mm	360 mm
Callipers	Six piston	Four piston

### Park Brake

Electrically operated independent park brake callipers on each rear brake disc.

### Brake System Features

- Anti Lock Braking System (ABS)
- Hydraulic Brake Assist (HBA)
- Electronic Brake force Distribution (EBD)
- Traction Control (TCS)

## Wheels

### Aston Martin Aluminium Alloy

Front	Rear
8.5j x 20"	11j x 20"

### Aston Martin Lightweight Forged Aluminium Alloy<sup>1</sup>

Front	Rear
8.5j x 20"	11j x 20"

<sup>1</sup>. Option.

## Wheel Nut Torque

Tighten every second nut until all five nuts are tightened. Tighten all wheel nuts in two stages.

1. To 80 Nm in one continuous movement.
2. To 180 Nm in one continuous movement.



## Tyres

### Tyre Loading

Tyres installed to this vehicle shall have a maximum load rating not less than 690 kg (front) and 925 kg (rear), or a load index of 95 (front) and 105 (rear) and a speed category of ZR.

 *The original equipment tyres, including winter tyres, installed to this vehicle are an approved specification, designated by 'AMR' on the sidewall.*

### Summer Tyres

	Front	Rear
Bridgestone S001	245/40 ZR 20 (95Y)	295/35 ZR 20 (105Y)

### Winter Tyres

	Front	Rear
Bridgestone	245/40 ZR 20 (95W)	295/35 ZR 20 (105W)

### Tyre Air Pressures

#### Cold Inflation<sup>1</sup>

Front	Rear
2.5 bar	2.6 bar

<sup>1</sup>. All Tyres.

## Bulbs

	Rating	Type
Headlamp dipped and main beam	35W	D1S HID
Front Indicator lamps		LED
Parking lamp		LED
Door lamps	5W	W5W
Side Repeater		LED
Front and rear footwell lamps	5W	W5W
Rear quarter lamps / Boot lamps / Reading lamps		LED
High Mounted Stop Lamp		LED
Registration plate lamps	5W	W5W

The rear lamp cluster is a sealed unit. If any rear cluster lamp fails to operate contact your Aston Martin Dealer.

## Vehicle Specification

### Body

- Four door coupe with four seats

Extruded aluminium bonded body structure with aluminium and composite body panels. Extruded aluminium door side impact beams.

### Towing

This vehicle is not engineered to tow any form of caravan, boat or trailer.

No towing devices are approved for installing to this vehicle, other than a front towing eye to aid recovery or loading of this vehicle onto a transporter.

## Vehicle Weights

### Kerb Weight

1990 kg

### Gross Vehicle Weight (GVW)

2410 kg

### Boot Maximum Load

50 kg<sup>1</sup>

<sup>1</sup>. Evenly distributed

## Vehicle Dimensions

### Interior

	Front	Rear
Effective Headroom	932 mm	936 mm
Shoulder Room	1392 mm	1322 mm
Hip Room	1410 mm	1100 mm
Effective Legroom	1086 mm	765 mm

### Boot Volume

Boot Configuration	Volume
Divider up	223 ltr
Divider down	393 ltr
Divider down, rear seats down	1029 ltr

### Exterior

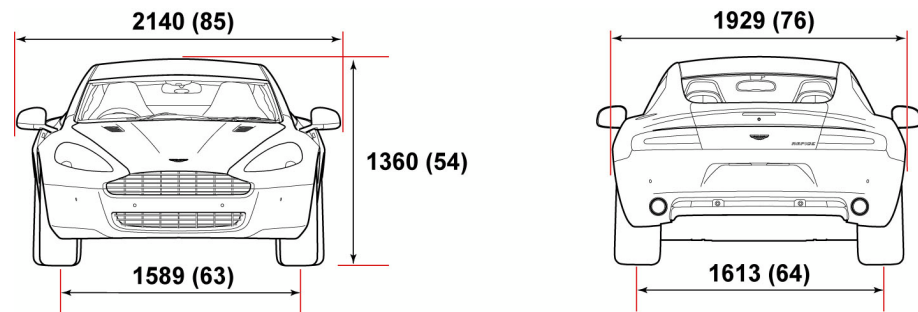

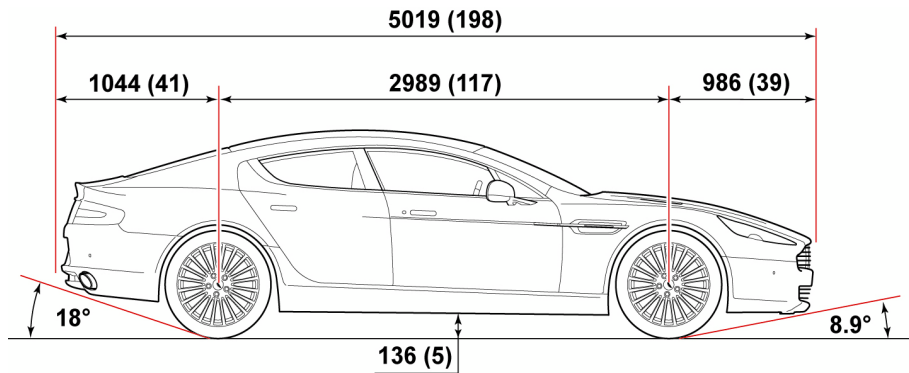

## Vehicle Features

### Interior

- Handcrafted leather and fabric trim
- Walnut facia veneer<sup>1</sup>
- Climate control
- Security system interacting with the central locking system and PATS immobiliser system
- Driver and front passenger dual stage front airbags
- Front and rear passengers side airbags
- Ten direction electrically adjusted front seats (including height adjustment)
- Position memory front seats (including door rear view mirrors)
- Heated seats (two heat levels)
- Cooled<sup>2</sup> and heated seats
- Organic electroluminescent (OEL) displays
- Infotainment centre
  - Bang & Olufsen audio system with radio, 6 CD autochanger and 1000W power output
  - Hands-free phone system
  - Menus for audio, hands-free phone, satellite navigation<sup>3</sup>, vehicle security and rear seat entertainment

<sup>1</sup>. Options.

<sup>2</sup>. Option.

<sup>3</sup>. Not available in all markets



- Rear seat entertainment system<sup>2</sup>.
- Hard Disk Drive (HDD) satellite navigation system<sup>3</sup>.

### Exterior

- Door mirrors
  - Heated, electrically adjusted
  - Position memory system
  - Power fold system
  - Auto fold system
- Electrically operated door windows
- Heated rear window
- Parking assist sensors

## Fluids and Capacities

### Recommended Fluids

**!** *To achieve the required high performance of synthetic lubricants, do not mix with mineral oils.*

**Engine Oil** - Mobil 1 Recommended (0W-40).

However, if this oil is not available, a fully synthetic 0W-40 oil meeting the specifications detailed below can be used. No other viscosity grades or specifications are acceptable.

Authority	Standard
API	SL / SJ / EC / CF
ACEA	A3 / B3 / B4
ILSAC	GF3

**!** *Do not mix OAT antifreeze with glycol based antifreeze.*

**Engine Coolant** - 50% water, 50% Havoline OAT

**Automatic Transmission Fluid** - Shell ATFM 1375-4

**Automatic Transmission Final Drive Oil** - Shell Spirax ASX 75W-90

**Brake and Clutch Fluid** - Castrol Response Super Dot 4

**Power Steering Fluid** - Pentosin CHF 11S

**Air Conditioner Refrigerant** - HFC134A

### Capacities

**Engine Sump (including filter)** - 11 ltr

**Automatic Final Drive and Cooler** - 1.6 ltr

**Engine Cooling System** - 15 ltr

**Automatic Gearbox and Cooler** - 9.7 ltr

**Power Steering Reservoir** - 1.3 ltr

**Screen Washer Reservoir** - 6.9 ltr

**Fuel Tank** - 90.5 ltr<sup>1</sup>

<sup>1</sup>. Approximately 88.5 ltr usable.



ASTON MARTIN



ASTON MARTIN



ASTON MARTIN

## Service

Pre-delivery Inspection.....	A.2
Servicing.....	A.4
Service Record.....	A.7
Anti Corrosion Inspection.....	A.9
Replacement of Airbag Units.....	A.10
Replacement of Seat Belt Pre-tensioners.....	A.11
Field Service Actions .....	A.11
Service Action Recalls .....	A.12

## Pre-delivery Inspection

This free series of checks is carried out on the vehicle by the Selling Dealer before delivery. The checks make sure that you receive a vehicle which matches the high quality standards set by Aston Martin Limited.

Make sure that the entry is stamped and signed as completed. The following checks will be made:

### Levels and Leaks

- Engine oil
- Power steering oil
- Brake fluid
- Engine coolant level
- Engine coolant specific gravity
- Windscreen washer fluid
- Fuel system
- Transaxle leak check
- Battery

### Mechanical Functions

- Throttle pedal operation
- Park brake operation
- Steering column adjustment and lock operation
- Seat adjuster rails

- Bonnet release and catch
- Door operation and locks
- Storage compartments
- Rear view mirror
- Boot release and catch
- Seat belt operation

### Electrical Checks

- Battery condition
- Gear selection
- Heated rear window
- Windscreen and headlamp washers
- Windscreen wipers
- Climate control
- Infotainment centre operation
- All speakers
- Reversing, registration plate and brake lamps
- Side and headlamps
- Rear fog lamps
- Hazard warning lamps
- Instrument illumination and dimmer
- Gauges and warning symbols

- Centre stack controls
- Horns
- Reset clock
- Blower motor
- Seat belt warning system
- Security system and vehicle key
- Interior lamps
- Cigar lighter<sub>1</sub>
- All seat functions
- Door window mechanisms
- Door and boot lamps
- Central locking system
- Filler flap lock operation
- Door mirror adjustments
- Interrogate fault codes
- Record battery open-circuit voltage
- Tyre pressure sensing
- Centre console controls

---

<sub>1</sub>. If installed on your vehicle.

## Wheels and Tyres

- Install locking road wheel nuts
- Check road wheel nuts torque
- Tyre pressures
- Tyre orientation

## Road Test

- Engine
- Transaxle
- Steering
- Brakes
- Wheel balance
- Adaptive dampers
- Exhaust by-pass system
- Gear shift operation
- Noise, vibration or harshness
- Air Conditioner performance
- Instruments operation
- Seat belt and buckle operation
- Steering wheel alignment
- Dynamic stability control, traction control, adaptive damping and anti-lock braking system operation

## Final Checks

- Drive belt tensioner operation
- Fuel and brake pipe security
- Fuel and fluid leaks
- Security of cooling hoses
- Exhaust catalyst security

## Hand-over Preparation

- Check function of locks and vehicle keys
- Clean bodywork and road wheel arch liners.
- Clean off all transit labels
- Valet vehicle
- De-grease windscreen
- Install carpets
- Remove interior protection
- Check Owner's Guide
- Check tools
- Install Registration plates
- Tyre sealant kit
- Towing eye
- Battery conditioner<sub>1</sub>
- Field Service Actions and Recall status

### Free Pre-delivery Inspection

\*4.75 Hours

Service Actions checked:

Open Service Actions completed:

Signature:

Date:

(Dealer Stamp)

\* Scheduled operation time.

<sub>1</sub>. If installed on your vehicle.

# Servicing

## Service Periods

Vehicle servicing is every 16,000 km or 12 month, which ever occurs first.

- 16,000 km or 12 month
- 32,000 km or 24 month
- 48,000 km or 36 month

## Service Tables

The following service schedules are recommended for this vehicle. The schedules may be modified if necessary. Please consult your Aston Martin Dealer for details of any service schedule updates.

16,000km 12 month	32,000km 24 month	
<b>Pre-Maintenance</b>		
x	x	Install vehicle protection kit and wing covers
x	x	Check bulletins, field service actions and recall status
<b>Fluids, Filters and Leaks Checks</b>		
x	x	Renew engine oil
x	x	Renew engine oil filter
x	x	Check for engine oil leaks
-	x	Renew air cleaner elements
x	x	Check transaxle for leaks. Top up if required

16,000km 12 month	32,000km 24 month	
Every 96,000 km or six years	Every 160,000 km or ten years	Check transaxle oil level. Top up if required
Every 64,000 km or four years		Renew differential oil and clean the filter
-	-	Check differential for leaks, top up if required
x	x	Check gearbox for leaks. Top up if required
Every 160,000 km or five years		Renew engine coolant - check concentration
x	x	Check engine coolant level. Top up if required
x	x	Check cooling and heating systems for leaks
x	x	Check fuel hoses, pipes and unions for leaks, security and condition
Every 12 Months		Renew brake fluid
x	x	Check power steering reservoir. Top up if required
x	x	Check power steering system for leaks, security and condition
x	x	Check brake hoses, pipes and unions for leaks, security and condition
x	x	Check suspension dampers for leaks
x	x	Top-up windscreen and headlamp washer reservoir
x	x	Check exhaust system for leaks
x	x	Check operation of exhaust by-pass valves
x	x	Check Air Conditioning system for leaks
-	x	Renew pollen filter

16,000km 12 month	32,000km 24 month		16,000km 12 month	32,000km 24 month	
<b>Mechanical Function Checks</b>					
x	x	Lubricate all door locks and hinges	-	x	Check tightness of drive shaft bolts
x	x	Lubricate bonnet secondary catch	x	x	Check rear view mirrors for security and function
x	x	Check security of the bonnet catch. Check that the bonnet secondary catch moves freely over its whole travel and returns smartly under spring pressure.	-	x	Check condition of underbody protection and wheel arch liners
x	x	Check and adjust the accessory drive belt tension. Renew if necessary	Every 64,000 km or four years		Clean throttle butterflies
x	x	Check park brake security	<b>Electrical Function Checks</b>		
x	x	Check condition of park brake pads	112,000 km		Renew spark plugs
x	x	Inspect brake pad wear and condition of discs and callipers. Replace brake pads and wear warning leads if 60% worn. Check front brake disc shields for fatigue and for clearance to discs.	x	x	Check and record battery voltage
x	-	Check wiper blade inserts. Renew if necessary	x	x	Clean and service the battery connections if required
-	x	Renew wiper blades	-	x	Check headlamp alignment. Adjust if required
x	x	Inspect coolant radiator, air conditioning condenser and transmission cooler. Clean if required	x	x	Check operation of all lamps
x	x	Check final drive cooler for debris. Clean if required	x	x	Check operation of all warning symbols
x	x	Check condition and operation of all seat belts	x	x	Check audible warnings including security system
x	x	Check security of exhaust system mountings and heat shields	x	x	Check operation of the horns
x	x	Check cooling system hoses security and condition	x	x	Check operation of the windscreen wipers
x	x	Check Air Conditioning hoses security and condition	x	x	Check windscreen and headlamp washers and jets
x	x	Check security and condition of suspension ball joints, gaiters and bushes	x	x	Check rear view mirrors for security and function
			x	x	Check and operate powerfold mirrors
			x	x	Check and operate electric windows
			x	x	Check service interval display. Reset
			-	x	Replace vehicle key battery

	16,000km 12 month	32,000km 24 month	
<b>Wheels and Tyre Checks</b>			
x	x		Check for correct tyre size, type and orientation
x	x		Check and report tyre tread depth
x	x		Check tyres for uneven, excessive wear or damage
x	x		Check and adjust tyre pressures
x	x		Check torque of road wheel nuts
x	x		Check road wheel rims for inner and outer damage.
x	x		Check tyre pressure monitoring colour coded valve collars for correct location
x	x		Check operation of tyre pressure sensors
x	x		Check 'use by' date of tyre repair kit.
<b>Anti Corrosion Check</b>			
x	x		Check body panels and underbody for corrosion starting from the inside - out (excluding stone chips).
<b>Gear Change Modes</b>			
x	x		Auto Drive
x	x		Touchtronic
x	x		Reverse
x	x		Sport

	16,000km 12 month	32,000km 24 month	
<b>Final Checks</b>			
x	x		Degrease windscreen
x	x		Carry out road test - including operation of all gearbox modes
x	x		Check ABS and traction control operation
x	x		Check operation of all seat belts and buckles
x	x		Check that fuel filler bowl rain drain is clear



## Service Record

The following service records cover the regular services at 16,000 km or 12 month, which ever occurs first, intervals. Make sure that at each service the appropriate entry is stamped and signed as completed.

**Vehicle Identification Number (VIN):**

**Date of Delivery:**

\* Scheduled operation time.

<b>16,000 km or 12 month</b> *3.85 Hours
Service Actions checked: _____
Open Service Actions completed: _____
Signature: _____
Date: _____
(Dealer Stamp)

<b>32,000 km or 24 month</b> *5.00 Hours
Service Actions checked: _____
Open Service Actions completed: _____
Signature: _____
Date: _____
(Dealer Stamp)

<b>48,000 km or 3rd year</b> *3.85 Hours
Service Actions checked: _____
Open Service Actions completed: _____
Signature: _____
Date: _____
(Dealer Stamp)

<b>64,000 km or 4th year</b> *5.00 Hours
Service Actions checked: _____
Open Service Actions completed: _____
Signature: _____
Date: _____
(Dealer Stamp)

<b>80,000 km or 5th year</b> *3.85 Hours
Service Actions checked: _____
Open Service Actions completed: _____
Signature: _____
Date: _____
(Dealer Stamp)

**97,000 km or 6th year**

\*5.15 Hours

Service Actions checked:  
\_\_\_\_\_Open Service Actions completed:  
\_\_\_\_\_Signature:  
\_\_\_\_\_Date:  
\_\_\_\_\_

(Dealer Stamp)

**29,000 km or 8th year**

\*5.00 Hours

Service Actions checked:  
\_\_\_\_\_Open Service Actions completed:  
\_\_\_\_\_Signature:  
\_\_\_\_\_Date:  
\_\_\_\_\_

(Dealer Stamp)

**61,000 km or 10th year**

\*5.20 Hours

Service Actions checked:  
\_\_\_\_\_Open Service Actions completed:  
\_\_\_\_\_Signature:  
\_\_\_\_\_Date:  
\_\_\_\_\_

(Dealer Stamp)

**113,000 km or 7th year**

\*6.30 Hours

Service Actions checked:  
\_\_\_\_\_Open Service Actions completed:  
\_\_\_\_\_Signature:  
\_\_\_\_\_Date:  
\_\_\_\_\_

(Dealer Stamp)

**145,000 km or 9th year**

\*4.05 Hours

Service Actions checked:  
\_\_\_\_\_Open Service Actions completed:  
\_\_\_\_\_Signature:  
\_\_\_\_\_Date:  
\_\_\_\_\_

(Dealer Stamp)

# Anti Corrosion Inspection

**Anti Corrosion Inspection 1st Year**  
Signature: \_\_\_\_\_  
Date: \_\_\_\_\_  
Odometer: \_\_\_\_\_  
  
(Dealer Stamp)

**Anti Corrosion Inspection 3rd Year**  
Signature: \_\_\_\_\_  
Date: \_\_\_\_\_  
Odometer: \_\_\_\_\_  
  
(Dealer Stamp)

**Anti Corrosion Inspection 5th Year**  
Signature: \_\_\_\_\_  
Date: \_\_\_\_\_  
Odometer: \_\_\_\_\_  
  
(Dealer Stamp)

**Anti Corrosion Inspection 2nd Year**  
Signature: \_\_\_\_\_  
Date: \_\_\_\_\_  
Odometer: \_\_\_\_\_  
  
(Dealer Stamp)

**Anti Corrosion Inspection 4th Year**  
Signature: \_\_\_\_\_  
Date: \_\_\_\_\_  
Odometer: \_\_\_\_\_  
  
(Dealer Stamp)

**Anti Corrosion Inspection 6th Year**  
Signature: \_\_\_\_\_  
Date: \_\_\_\_\_  
Odometer: \_\_\_\_\_  
  
(Dealer Stamp)

**Anti Corrosion Inspection 7th Year**

Signature: \_\_\_\_\_

Date: \_\_\_\_\_

Odometer: \_\_\_\_\_

(Dealer Stamp)

**Anti Corrosion Inspection 9th Year**

Signature: \_\_\_\_\_

Date: \_\_\_\_\_

Odometer: \_\_\_\_\_

(Dealer Stamp)

**Anti Corrosion Inspection 8th Year**

Signature: \_\_\_\_\_

Date: \_\_\_\_\_

Odometer: \_\_\_\_\_

(Dealer Stamp)

**Anti Corrosion Inspection 10th Year**

Signature: \_\_\_\_\_

Date: \_\_\_\_\_

Odometer: \_\_\_\_\_

(Dealer Stamp)

**Replacement of Airbag Units**

Every 10 years from the date of vehicle registration, all airbag units must be replaced. To make sure this is completed correctly and safely, this work should be carried out by your Aston Martin Dealership.

**Airbag Replacement 10th Year**

Signature: \_\_\_\_\_

Date: \_\_\_\_\_

Odometer: \_\_\_\_\_

(Dealer Stamp)

## Replacement of Seat Belt Pre-tensioners

Every 10 years from the date of vehicle registration, all seat belt pre-tensioners must be replaced. To make sure this is completed correctly and safely, this work should be carried out by your Aston Martin Dealership.

### Seat Belt Pre-Tensioners Replacement 10th Year

Signature:

Date:

Odometer:

(Dealer Stamp)

## Field Service Actions

Action No.

Date

Dealer

Action No.

Date

Dealer





# Aston Martin Assistance

Emergency Service .....	B.2
Benefits.....	B.3
Alternative Travel Arrangements.....	B.4
What To Do In An Emergency.....	B.6
European Autoroute Restrictions .....	B.7
What is not Covered .....	B.7
Schedule - Eligible Vehicles .....	B.11

## Emergency Service

---

As the owner of an Aston Martin vehicle you should enjoy a high standard of trouble free motoring. However, should the unexpected occur, our worldwide Dealer network is there to help you. Details and contact telephone numbers are shown in the Dealer Directory. In the UK and specific countries within Europe, a special additional emergency service, known as '**Aston Martin Emergency Assistance**', has been designed to provide you and your passengers with the help you need quickly and efficiently should your vehicle suffer a Breakdown Incident <sup>1</sup>.

### Vehicles Covered

The benefits of Aston Martin Emergency Assistance are applicable to new and / or used Aston Martin vehicles purchased from an authorised Aston Martin Dealer in one of the following countries; Austria, Belgium, Croatia, Czech Republic, Denmark, France, Germany, Italy, Netherlands, Norway, Portugal, Russia, Spain, Sweden, Switzerland and the UK.

At completion of your purchase, your Aston Martin Dealer will register your vehicle for Aston Martin Emergency Assistance. From registration, your vehicle will be entitled to Aston Martin Emergency Assistance (the '**Vehicle**'). For more details of what constitutes an eligible Vehicle, please refer to the Schedule.

An eligible Vehicle is entitled to receive Aston Martin Emergency Assistance for a period of 36 months from the date of registration with the service provider. Owners of eligible Vehicles can also obtain Aston Martin Emergency Assistance when travelling temporarily outside their Country <sup>2</sup>, within Europe.

### Europe is defined as:

Andorra, Austria, Belgium, Bosnia-Herzegovina, Bulgaria, Crete, Croatia, Czech Republic, Denmark, Estonia, Finland, France, Germany, Gibraltar, Greece, Hungary, Italy, Latvia, Liechtenstein, Lithuania, Luxembourg, Monaco, Netherlands, Norway, Poland, Portugal (not Madeira), Republic of Ireland, Romania, Russia, San Marino, Slovakia, Slovenia, Spain (including the Balearic Islands and Canary Islands), Sweden, Switzerland, Turkey (European Part), Ukraine, and Vatican City.

### United Kingdom (UK) is defined as:

England, Scotland, Wales, Northern Ireland, Channel Islands and Isle of Man.

---

<sup>1</sup> A **Breakdown Incident** means an event where an eligible Vehicle is immobilised due to a breakdown in circumstances where it qualifies for Aston Martin Emergency Assistance, including home-starts, fire, broken glass, accident, theft or vandalism. Furthermore, Aston Martin Emergency Assistance covers you in the event of safety-related defects, which render the Vehicle illegal to drive. These defects relate to, for example, failure of the seat belts, windscreen wipers, direction indicators, front and rear lamps.

---

<sup>2</sup> '**Country**' means the country in which your Vehicle is registered.



## Benefits

---

The service provider, appointed by Aston Martin to provide the Aston Martin Emergency Assistance services (the 'Service Provider') will provide the following benefits dependent on requirements to entitled Vehicles in both the home Country and Europe as defined.

### Roadside Assistance

The Service Provider's Patrol vehicle should promptly arrive with you after your call has been placed. You may also book an appointment for a convenient time.

Aston Martin Emergency Assistance shall provide you with updates on its estimated time of arrival via your preferred communication method.

If following a Breakdown Incident in an area of coverage, your journey cannot be completed, and where the Vehicle cannot be repaired at the roadside, Aston Martin Emergency Assistance shall organise recovery of the Vehicle, including any luggage contained in the Vehicle at the time. Your Vehicle and luggage shall be transported to the nearest Aston Martin Dealer, without distance or financial limitation.

If the Vehicle cannot be repaired at the roadside or at your home address within a reasonable time period (45 minutes), the Service Provider will take you, the Vehicle and your passengers to the nearest Aston Martin Dealer. In the event that you (or your passengers) need to keep an important appointment, you will be taken there before the disabled Vehicle is transported to its required destination.

Should the Breakdown Incident occur outside of workshop hours, Aston Martin Emergency Assistance shall arrange for secure storage of the Vehicle until the next working day. The Vehicle shall arrive at the Dealer on the next working day, within two hours of the Dealership opening.

If the nearest Dealer, to where the eligible Vehicle has been towed, is able to carry out the repairs at its premises, then the Vehicle will be repaired there.

Once the Vehicle is at a Dealership for repair, Aston Martin Emergency Assistance will keep in contact with the Dealer to follow the progress of the repair, and if necessary, arrange any extension of a replacement vehicle with Aston Martin Customer Service.

### Home Start

Aston Martin Emergency Assistance will provide all the benefits of Roadside Assistance at the Vehicle's registered address.

### Recovery

If Aston Martin Emergency Assistance cannot repair your Vehicle at the roadside, the Service Provider will arrange recovery of you and your Vehicle to the nearest Aston Martin Dealer.

If your Vehicle has been involved in an accident and has gone off the road and needs to be salvaged before towing, Aston Martin Emergency Assistance will charge you for services on a 'Pay for Use' basis and you may be able to claim these back from your insurance company.

You will be covered for costs of recovery and towing (including any handling fee) but you may be charged for any costs incurred if the Vehicle is, for example, disabled by floods or snow-affected roads, is embedded in sand or mud, or is not easily accessible.

### Relay Plus

If your Vehicle cannot be repaired and / or recovery is initiated to an Aston Martin Dealer, the Service Provider will provide alternative travel options for you. You will be entitled to receive one of the following additional services:

a) A replacement vehicle for up to two working days in your Country, or 14 days if the Breakdown Incident occurs outside your Country (a collection and delivery service, or equivalent, is available from chosen suppliers subject to availability and supplier's terms and conditions);

b) Onward transportation; or

c) Overnight accommodation.

### Vehicle Collection Following Repair

Following repairs organised by Aston Martin Emergency Assistance, the cost of a first class rail ticket or (if rail transport would normally exceed six hours) a business class air ticket will be met to permit you or a person you designate to collect the repaired Vehicle.

Alternatively, arrangements can be made for your Vehicle to be returned to your home or business address, whichever is the nearest to the repairing Dealer. Alternative addresses closer to the repairing Dealer may also be considered.

## Alternative Travel Arrangements

If the Service Provider estimates that the repairs to your Vehicle will take more than eight hours, the Aston Martin Emergency Assistance will cover your reasonable costs for alternative necessary travel, including for members of your party.

Reasonable additional expenses shall be covered for one or a combination of the following:

- Replacement vehicle costs to a maximum of two working days in your Country and up to 14 days outside your Country
- Air fares (business class ticket)
- Rail fares (first class ticket)
- Local taxi fares
- Any other transport equivalent to first class rail fares

### Replacement Vehicle

If following a Breakdown Incident:

- Your Vehicle is immobilised
- Roadside repairs are unsuccessful
- If repair of the Vehicle is not possible within the same day after towing to the Dealer

Aston Martin Emergency Assistance will organise free of charge, a replacement vehicle for you until completion of the repairs. The replacement vehicle will include fully comprehensive insurance <sup>1</sup>, with an option to upgrade to include collision damage waiver.

The loan of this replacement vehicle will not exceed two working days (in your Country) or, if the Breakdown Incident occurred outside your Country, 14 days plus two working days after your return to your home country.

Aston Martin Emergency Assistance aim to make sure that the replacement vehicle is a suitable vehicle for you. A priority for the choice of the replacement vehicle is a hire car of category G or equivalent, where available. Specially adapted replacement vehicles will not be provided.

The replacement vehicle will be delivered to you, where possible, but if you prefer, taxi costs for collecting the replacement vehicle, will be met by Aston Martin Emergency Assistance.

---

<sup>1</sup>. Unless the driver is under 21 years of age, where there may be an additional charge incurred.

---

You will be responsible for fuelling and basic maintenance of the replacement vehicle, while under their care. You will also be responsible for paying any deposit required by the vehicle Hire Company.

Once the repair on your Vehicle is complete, the replacement vehicle will then either be returned to the vehicle Hire Company or collection will be arranged where possible, at your request.

If the replacement vehicle has been kept beyond the term of the permitted loan period (as noted above), you will be responsible for any additional charges incurred for the extended period. If you cannot fulfil the nominated vehicle Hire terms and conditions, or circumstances prevent you from qualifying to hire the vehicle, and alternative mobility arrangements are more appropriate, then onward travel arrangements or hotel accommodation will be provided instead. The vehicle hire agreement will be between you and the relevant supplier and will be subject to that supplier's Terms and Conditions. These will usually require or include (amongst other things):

- Production of a full driving licence valid at the time of issue of the hire vehicle
- Limits on acceptable endorsements

- Limitations on the availability and, or engine capacity of the replacement vehicle
- A deposit, e.g. for fuel
- Drivers to be aged at least 18 or 21 years depending on Country, and to have held a full driving licence for at least 12 months.

### **Onward or Home Journey**

If following a Breakdown Incident that occurs more than 80 km (50 miles) from your place of residence, your Vehicle cannot be repaired at the roadside on the same day of the Breakdown Incident, Aston Martin Emergency Assistance will cover:

- The costs of the journey from the place of the Breakdown Incident to the nearest Dealer
- The costs of a replacement vehicle as outlined above
- Where necessary, taxi costs for one journey to the nearest accessible train station or airport, for you and your passenger(s)
- Where necessary, the costs of a first class train journey for you and your passenger(s). If the train journey exceeds six hours, the cost of a scheduled flight (Business Class) for you and your passenger(s).

Aston Martin Emergency Assistance will reimburse you for reasonable costs incurred relating to the above, upon receipt of a claim letter from you, detailing the circumstances of the claim, along with receipts for all transport costs claimed. All claim letters must be directed to Aston Martin Emergency Assistance at The AA, Relay Plus Claims, Aston Martin Emergency Assistance, Fanum House, Basingstoke, Hampshire RG21 4EA, United Kingdom. Only costs directly connected with the Breakdown Incident will be covered. The refund process to you shall be managed by Aston Martin Emergency Assistance.

### **Repaired Vehicle Re-delivery**

Aston Martin Emergency Assistance will attempt to contact you within 24 hours of successful repair at the Dealer in order to arrange re-delivery of the repaired Vehicle to either your home or place of work, as you request. Alternative addresses closer to the Repairing Dealer may also be considered.

## Hotel

If following a Breakdown Incident that occurs more than 80 km from your place of residence, and your Vehicle cannot be repaired at the roadside on the day of the Breakdown Incident, accommodation costs for you and your passenger(s) shall be covered for the duration of the repair, for up to a maximum of two nights if the Breakdown Incident occurs in your Country, or seven nights if the Breakdown Incident occurs outside your Country. You shall be responsible for any excess costs.

## Repatriation of Un-repaired Vehicle from Abroad

If the Vehicle cannot be repaired by Aston Martin Emergency Assistance within an agreed time schedule (three working days), the costs for transporting the Vehicle and its contents from the Dealer to the home Country Dealer, will be covered by Aston Martin Emergency Assistance.

Aston Martin Emergency Assistance shall arrange the safe repatriation of the Vehicle at the least cost, while respecting the need to deliver the Vehicle to the home Dealer within ten consecutive days.

Aston Martin Emergency Assistance will cover the costs for parking the Vehicle, pending repatriation or import. It may be necessary for Aston Martin Emergency Assistance to repatriate a caravan or trailer on tow at the time of the Breakdown Incident together with the Vehicle if the Vehicle cannot be repaired abroad by your return date.

## What To Do In An Emergency

Should assistance be required in the unlikely event of a Breakdown Incident, simply contact Aston Martin Emergency Assistance using the relevant telephone number listed below. It is important that you call the appropriate number should you require assistance.

 *It may be helpful to have the relevant telephone numbers entered into your telephone 'phone book'.*

UK: 0800 316 1178 <sup>1</sup>

Europe: 00 800 28 86 28 86 <sup>1</sup>.

Europe: 00 33 472 172 508

Please do not make your own arrangements as Aston Martin Emergency Assistance will not be able to reimburse you. If you are in a remote location and need assistance, the time taken to receive the assistance may be longer because of distance and local restrictions.

## Vehicle Identification and Location

To minimise delay, please have the following information available:

---

<sup>1</sup>. Calls from landlines shall be free. Calls from mobile phones will be charged at standard mobile network rates.

## European Autoroute Restrictions

- Your name
- Aston Martin model
- The Vehicle Identification Number (VIN). The last six digits from the VIN label in the corner of the windscreen
- The location of the vehicle
- Vehicle registration number and colour
- Telephone number where you can be contacted
- Description of the concern experienced

If assistance is required on a French Autoroute or on certain Autoroutes in other European countries, you must use the official SOS boxes at the side of the road in order to arrange initial assistance or recovery. You will be connected to the authorised Autoroute Assistance Service because these roads are privatised. Neither Aston Martin Emergency Assistance nor any other assistance organisations are allowed to assist on these roads.

Once your Aston Martin has been recovered from the Autoroute, you should contact Aston Martin Emergency Assistance at the earliest opportunity to make sure that any further assistance arrangements you require can be made on your behalf.

Aston Martin Emergency Assistance will advise you how to reclaim costs incurred for recovery from the Autoroute.

## What is not Covered

Aston Martin Emergency Assistance is thorough and comprehensive; however, claims cannot be met as a result of any of the following:

1. Where you, or anyone else acting on your behalf, make repair or service arrangements without authorisation (and a file number) from Aston Martin Emergency Assistance.
2. Where any loss, theft, damage, death, bodily injury, cost or expense that is not directly associated with the incident that caused you to claim, unless expressly stated in this policy
3. If the Breakdown Incident is due to fire, theft, accident or vandalism, your costs will not be covered by Aston Martin Emergency Assistance but should be met by third party insurance covering the incident.
4. Damage or injury intentionally caused by you or resulting from your participation in a criminal offence.
5. If your Vehicle is kept in an un-roadworthy condition or has not been serviced in accordance with the Manufacturer's recommendations.

6. Any costs that would have been payable by you, such as petrol, toll charges, parking fees, cost of meals, drinks, telephone calls and/ or newspapers or any other costs not specifically stated as being covered by Aston Martin Emergency Assistance, which may be incurred by you and/ or the other member(s) of your party as a result of and/ or in connection with the Breakdown Incident.
7. Release fees: Should your Vehicle be stolen and subsequently recovered by the police, you may be asked to pay a release fee before we can remove your Vehicle to an authorised Aston Martin Dealer.
8. Specialist charges: In the event that the use of specialist equipment is required to give assistance when your Vehicle has, for example, gone off the road, is in a ditch, is standing on soft ground, sand, shingle, stuck in water or snow or has been immobilised by the removal of its wheels, we will arrange recovery but you will be responsible for the costs of any specialist equipment required. The costs may be refundable under the terms of your motor insurance policy.
9. Adverse weather conditions: On those occasions when we experience adverse weather conditions, such as high winds, snow, floods, etc., external resources may be stretched and some operations become physically impossible until the weather improves. At such times, our priority is to make sure that you and your passengers are taken to a place of safety and so the recovery of your Vehicle may not be possible until weather conditions permit.
10. Customer induced breakdown incidents are not covered under Aston Martin Emergency Assistance. However, Aston Martin and the Service Provider will, at their sole discretion, assist you if you request it. However we are not obligated to provide assistance and you shall be responsible for any charges resulting from any assistance given caused by a customer induced fault. In such circumstances, a swipe card deposit maybe taken by the Service Provider. Assistance in such circumstances will not include additional benefits (replacement vehicle, onward journey, hotel accommodation). Customer- induced faults may include, for example, the following:
  - Lock-outs / lost keys
  - Broken keys
  - Discharged battery
  - Running out or loss of fuel
  - Use of wrong fuel (no replacement at the location of breakdown, only towing)
  - Tyre damage
  - Road traffic accidents
11. Lockout / lost keys: Whilst we will always try to provide assistance by the most practical method, should you be unable to gain entry to your Vehicle, modern security systems make it extremely difficult for this to be done should spare keys not be available. If a forced entry is required, you will be asked to sign a declaration stating that you have given permission for this to take place and that any costs for resultant damage will be your sole responsibility.
12. Aston Martin Emergency Assistance shall not be required to provide services in the following circumstances:
  - a) in respect of Vehicles not displaying a valid road fund licence;

---

b)in respect of eligible Vehicles situated on private property (for example garage premises) unless you can establish to the reasonable satisfaction of Aston Martin Emergency Assistance that permission has been given by the relevant owner or occupier;

c)Vehicle servicing or re-assembly where this is required as a result of neglect or unsuccessful work on the Vehicle other than on the part of the Service Provider or its agents;

d)the recovery of any Vehicles bearing trade plates or which Aston Martin Emergency Assistance has reason to believe have just been imported or purchased at auction;

e)the transportation of immobilised Vehicles where Aston Martin Emergency Assistance considers this to be part of a commercial activity;

f)assistance for Vehicles broken down as a result of taking part in any 'Motor Sport Event', including, without limitation, motor racing, rallying, speed or duration tests or practice thereof, trials or time-trials, auto test (other than auto tests performed by the Client using roadworthy, road legal cars on public roads), but excluding 'Concours d'elegance' events, track test days for road-legal Vehicles or rallies held exclusively on open public roads where participants are required to comply with the normal rules of the road (save for Aston Martin organised and controlled track day events);

g)where the police, highways agency and / or other emergency service require that your Vehicle be recovered by a third part

h)where your entitlement to Aston Martin Emergency Assistance lapses or if your Vehicle is no longer considered eligible for Aston Martin Roadside Assistance, the Service Provider may charge you directly for the Services provided. Any such charges will be charged on a 'pay for use' basis and will constitute a direct contract between you and the Service Provider. If it is determined that Aston Martin is at fault for the Vehicle not being recorded as an eligible Vehicle, then Aston Martin shall pay the relevant charges;

l)assistance for routine maintenance and running repairs of the Vehicle such as fixing faulty radios, interior light bulbs and heated rear windows;

j)for transit risk insurance, which Aston Martin Emergency Assistance recommends you take out where a Vehicle is to be repatriated;

k) where locksmiths, body-glass or tyre specialists are required. Aston Martin Emergency Assistance will endeavour to arrange for their assistance on your behalf, however, you will be responsible for the costs of their services. Further, if use of a locksmith or other specialist would, in Aston Martin Emergency Assistance's opinion, mobilise the vehicle, no further service will be given for the breakdown in question  
l) the transportation of any animal or pets shall be at the sole discretion of the Service Provider.

13. The Service Provider may charge you directly for:

- a) any replacement component, lubricant and / or fuel (the 'Parts') or consumable items supplied (except where Aston Martin has provided or paid for such Parts);
- b) any extension of the Services which you are entitled to receive in connection with this Agreement (which shall be performed by the Service Provider (in its absolute discretion) at your request;

c) the use of any specialist lifting or towing assistance needed to recover your Vehicle if your Vehicle has gone off the road, is in a ditch, sunk in soft ground, sand or shingle or when it is stuck in snow or flood water;

d) any additional charges resulting from the failure to carry legal and serviceable spare wheel(s) or tyre(s) in the Vehicle. Aston Martin Emergency Assistance will endeavour to arrange assistance from a third party on your behalf but you will be responsible for the costs of the call out and/ or for any repair;

e) the cost of garage or other labour required to repair the Vehicle, other than that provided by Aston Martin Emergency Assistance at the scene of the Breakdown Incident;

f) any costs of draining or removing fuel, lubricants or other fluids as a result of the introduction of an inappropriate substance;

g) transportation of personal effects, goods, vehicles, boats or other waterborne craft on or in the Vehicle and any trailer or caravan. Aston Martin Emergency Assistance will not consider any claim for loss resulting from damage to / loss of use of these items. Such items remain your responsibility at all times.

14. If following a Breakdown Incident, the Service Provider, its third party garage agent or subcontractor makes a temporary repair to your Vehicle (for these purposes, a temporary repair shall mean temporary repairs of the Vehicle where the underlying cause of the Vehicle's failure is not resolved), then the Service Provider, its third party garage agent or subcontractor shall recommend you to have such temporary repair made good by a Dealer.



## Schedule - Eligible Vehicles

---

### New Vehicles

Any Aston Martin vehicle which is sold directly by Aston Martin or a Dealer in the UK or European Territories and which is first registered in the UK or European Territories (as appropriate).

### Used Vehicles

Those used vehicles registered in the UK or the European Territories in respect of which an Extended Warranty has been started.

### In All Cases

- Maximum Gross Vehicle Weight (including any caravans or trailers being towed at the time of the Breakdown Incident): 3500 Kg
- Maximum Vehicle Length: 5.5 m
- Maximum Vehicle Width (including any caravans or trailers being towed at the time of the Breakdown Incident): 2.3 m
- Maximum Vehicle Height: 3 m

The dimensions detailed above will be calculated taking into account anything attached to the relevant eligible Vehicle at the time of the relevant Breakdown Incident and any trailer or caravan, including but not limited to towing equipment, any carriers or racks (e.g. bike or luggage), or anything else attached to the Vehicle or the carriers / racks.

Vehicles must be built to manufacturer's specifications, display a road fund licence, and where applicable, hold a certificate of roadworthiness.



ASTON MARTIN



ASTON MARTIN



ASTON MARTIN



ASTON MARTIN

# Aston Martin Warranty

Vehicle Warranty .....	C.2	Consumer Law .....	C.7
Anti Perforation Corrosion Protection Warranty.....	C.2	Owner Details.....	C.7
Period of Cover.....	C.3	Vehicle Details.....	C.7
Who May Repair the Vehicle .....	C.3	Owner Warranty Transfer (3) .....	C.9
Wear and Tear Items.....	C.3	Owner Warranty Transfer (2) .....	C.9
What is Not Covered.....	C.4	Owner Warranty Transfer (1) .....	C.9
Customer Responsibility .....	C.5	Owner Warranty Transfer (6) .....	C.11
Warranty Coverage when Touring.....	C.6	Owner Warranty Transfer (5) .....	C.11
Aston Martin Extended Warranty.....	C.6	Owner Warranty Transfer (4) .....	C.11

## Vehicle Warranty

Aston Martin gives a Warranty for each new Aston Martin vehicle and each replacement vehicle or assembly manufactured or supplied by the Company to be free from defects in material and workmanship under normal use and service for the applicable Warranty period.

The warranties provided herein are for the benefit of the original purchaser and any subsequent owner during the relevant Warranty Period (defined below) in the Serviced Countries (defined below).

An Aston Martin vehicle is built and homologated to support the Region for which it is manufactured and is compliant with the local regulatory requirements of that Region. As a result, the warranties cover Aston Martin vehicles that are built for and supplied to the Region.

For the purposes of this Owner's Guide, Region means one of the following territories:

- The Americas, including the United States, Canada, and South America; or
- The United Kingdom, Europe, Russia and South Africa; or
- The Middle East, North Africa and India; or
- Asia Pacific, including China, Japan, Taiwan, Hong Kong, Singapore, Australia and New Zealand.

'**Serviced Countries**' means either: (a) any country in the Region from which your Aston Martin vehicle was purchased, where there is an Aston Martin authorised dealer or repairer; or (b) any country agreed in writing with Aston Martin.

 *Tyres are covered separately by the tyre manufacturer. Dealers are expected to offer assistance to the customer in pursuing a claim against the tyre manufacturer.*

### Exchange Parts Under Warranty

New parts will only be used for repairs at PDI and during the first three months or 5000 km (which ever occurs first) from the date the vehicle is handed over to the first retail customer. Thereafter exchange parts must be used where available under Aston Martin's exchange plan.

## Anti Perforation Corrosion Protection Warranty

The vehicles bodywork is protected by an Anti Perforation Corrosion Warranty. Should any part of the bodywork of the Aston Martin vehicle be perforated, the panel(s) affected by the perforation will be repaired or replaced.

The term 'perforation' means a hole that penetrates through a body panel from the inside.

## Period of Cover

The period of cover for all types of warranty commences on the day the vehicle is handed over to the first retail customer.

The Vehicle Warranty period of cover is three years with unlimited mileage.

The Anti Perforation Corrosion Warranty period of cover is ten years with unlimited mileage.

## Who May Repair the Vehicle

Franchise holders or Approved Repairers, who are appointed and receive full technical support from Aston Martin, provide facilities for the servicing and repair of Aston Martin motorcars. Only such Franchise Holders or Approved Repairs will under the terms of this warranty, repair replace or readjust, free of charge to the owner, any part or assemble proved to Aston Martins satisfaction to show a defect in materials or workmanship within the applicable period.

## Wear and Tear Items

Items that are subject to wear and tear are generally divided into two categories, namely those specified for replacement or adjustment during scheduled maintenance and those that require replacement or adjustment dependent upon conditions of use.

### Scheduled Maintenance Items

The items listed below are covered by the Vehicle Warranty up to the first scheduled change point that replacement or adjustment is required during scheduled maintenance operations. The customer literature supplied with the new Vehicle includes a service book setting out such scheduled maintenance operations.

- Drive Belts
- Spark Plugs
- Oil, air, pollen and fuel filters

 *The period of warranty cover for any item may not exceed the time and distance limitation of the vehicle warranty.*

## Wear and Tear Items

The items listed below are recognised as having a limited service life or are subject to wear or damage. However, these items are covered by the vehicle warranty for up to one year or the first service, whichever ever occurs first.

- Wiper Blades
- All Light bulbs  
HID headlamp bulbs and instrumentation illumination bulbs are covered by the full vehicle warranty.
- Wheel alignment and balancing
- Adjustments, including but not limited to: headlamp and hinged panel adjustments, suspension tightening, steering geometry adjustments, emission and fuel systems checks and park brake cable adjustments
- Remote handset batteries

 *Brake pads, brake discs and other friction related components are not covered when replacement is due to wear and tear, but they are covered against manufacturing defects (whether in material or workmanship) for the duration of the Vehicle Warranty.*

## Consumables

Replacement or top up of consumable fluids, e.g. oils, antifreeze, brake fluid, windscreen wash solution and refrigerant, will only be covered when they are used as part of a warranty repair.

## What is Not Covered

### Vehicle Warranty

Aston Martin is **not** responsible for any repair or replacement that is required as a direct result of:

- Normal wear and tear
- Failure to properly maintain the vehicle in accordance with Aston Martin's maintenance schedules and service instructions
- Failure to use Aston Martin specified parts or fluids during a warranty repair (or parts of equivalent quality during a retail repair)
- Damage resulting from neglect, accident, flooding or improper use
- Any modification of the vehicle or parts which is not authorised by Aston Martin, including any engine performance enhancement modifications
- Refilling or topping up with incorrect fuel, e.g. diesel instead of petrol
- Use of bio ethanol alternative fuels
- Defects caused as a result of the vehicle being used in motor sport or track events or for any other purpose other than normal private or commercial use

- 
- Any vehicle that has had its vehicle identification number altered or removed, or on which the odometer reading has been unlawfully altered

### **Paint Surface and Corrosion Protection**

Aston Martin is not responsible for any repair or replacement that is required as a direct result of the following:

- Failure to properly maintain paint and bodywork by regular cleaning in accordance with Aston Martin instructions
- Factors beyond Aston Martin's control, such as environmental hazards (including industrial fallout, storm damage, acid rain) and damage (including stone chips, scratches and use of unsuitable cleaning agents)
- Accident repairs using materials or methods of repair that have not been approved by Aston Martin
- Alterations of the vehicle from Aston Martin's original specification
- Failure to rectify on a timely basis any paint or corrosion damage as recorded in the vehicle documentation by a dealer at the time of the annual inspection

### **Other Exclusions**

The Aston Martin warranty excludes liability for any lost time, inconvenience, loss of transportation, or any other incidental or consequential damage you (or anyone else) may incur as a result of a defect covered by this warranty.

## **Customer Responsibility**

---

The customer literature will describe the proper care and use of the vehicle. Proper maintenance and use guard against major repair expenses resulting from misuse, neglect or inadequate maintenance, and may help increase the value that the customer may receive when selling the vehicle.

The Customer is responsible to:

- Make sure that the vehicle is maintained in accordance with the vehicle service and maintenance guide published in the customer literature  
Failure to perform maintenance promptly and in accordance with Aston Martin's specified service intervals will invalidate warranty coverage on the parts affected.
- The customer is required to take the vehicle to a dealer for any warranty repairs as soon as practicable after a defect is detected
- Make sure that the Service and Maintenance schedule has been stamped by the servicing dealer after the completion of a scheduled service operation
- Make sure that paint and bodywork is maintained by regular cleaning in accordance with the vehicle manufacturer's instructions

- Make sure that the body panels are examined annually by an authorised Aston Martin Dealer and that this inspection is recorded in the Owners Guide

## Warranty Coverage when Touring

---

Aston Martin has a comprehensive service network in most parts of the world. Any authorised Aston Martin dealer can carry out repairs under the terms of the vehicle warranty. Under normal circumstances, the customer should not be required to pay for any warranty work performed by an Aston Martin dealer.

It is the customer's responsibility to produce the warranty documentation issued with the new vehicle. This establishes the customer's right to warranty coverage and the relevant maintenance and service records. If the customer is unable to do so, the dealer should seek advice from Aston Martin.

## Aston Martin Extended Warranty

---

Aston Martin Extended Warranty is specifically designed to provide the customer with first class after-sales protection from unexpected repair costs when the vehicle warranty has expired, and the knowledge that your Aston Martin will be repaired by trained technicians using only genuine Aston Martin parts.

Contact your Aston Martin Dealer for more information on the benefits and protection provided by the Aston Martin Extended Warranty.



## Consumer Law

The Aston Martin warranties are manufacturers' warranties that supplement and do not affect your legal rights under the vehicle purchase agreement with your selling dealer or under applicable national legislation governing the sale of consumer goods.

## Owner Details

Name::

Address::

:

:

Post Code::

Signature:

Date:

(Dealer Stamp)

## Vehicle Details

Registration Plate No.:

VIN No.:

Engine No.:

Warranty Start Date:

If the vehicle is sold, the benefits of any un-expired portion of the warranties can be transferred to the new owner.

The new owner should complete a 'tear off' sheet (next page) and send the new details to:

Aston Martin Warranty Department  
Aston Martin Lagonda Limited  
Banbury Road,  
Gaydon,  
WARWICK  
Warwickshire,  
CV35 0DB,  
England



ASTON MARTIN



ASTON MARTIN



ASTON MARTIN

**Owner Warranty Transfer (3)****Registration plate No.:****VIN No.:****Recorded mileage (km):****Date of Purchase:****Name:****Address:**

:

:

:

**Post Code:****Telephone No.:****Signature:****Date:****Owner Warranty Transfer (2)****Registration plate No.:****VIN No.:****Recorded mileage (km):****Date of Purchase:****Name:****Address:**

:

:

:

**Post Code:****Telephone No.:****Signature:****Date:****Owner Warranty Transfer (1)****Registration plate No.:****VIN No.:****Recorded mileage (km):****Date of Purchase:****Name:****Address:**

:

:

:

**Post Code:****Telephone No.:****Signature:****Date:**



ASTON MARTIN



ASTON MARTIN



ASTON MARTIN

**Owner Warranty Transfer (6)****Registration plate No.:****VIN No.:****Recorded mileage (km):****Date of Purchase:****Name:****Address:**

:

:

:

**Post Code:****Telephone No.:****Signature:****Date:****Owner Warranty Transfer (5)****Registration plate No.:****VIN No.:****Recorded mileage (km):****Date of Purchase:****Name:****Address:**

:

:

:

**Post Code:****Telephone No.:****Signature:****Date:****Owner Warranty Transfer (4)****Registration plate No.:****VIN No.:****Recorded mileage (km):****Date of Purchase:****Name:****Address:**

:

:

:

**Post Code:****Telephone No.:****Signature:****Date:**



ASTON MARTIN



ASTON MARTIN



ASTON MARTIN

# Authorised Body Repairers



Australia.....	D.2	Germany.....	D.7	Norway.....	D.11
Austria.....	D.2	Hong Kong.....	D.8	Portugal.....	D.12
Belgium.....	D.3	Italy.....	D.8	Russia.....	D.12
Canada.....	D.3	Japan.....	D.9	Saudi Arabia.....	D.12
China.....	D.3	Kuwait.....	D.9	Singapore.....	D.13
Denmark.....	D.4	Lebanon.....	D.10	South Africa.....	D.13
Dubai.....	D.4	Monaco.....	D.10	Spain.....	D.13
England.....	D.4	Netherlands.....	D.10	Switzerland.....	D.14
France.....	D.7	New Zealand.....	D.11	USA.....	D.14
		Northern Ireland.....	D.11	Scotland.....	D.16

## Australia

---

**Cat A Exclusive Body Werks**

---

23 George Street, Granville, Sydney, New South Wales 2142  
Phone: +61 2 9760 0353  
Associated Dealer: Trivett Classic Garage Pty Ltd.

---

**Cat B File Finish**

---

180 Christmas St, Fairfield, VIC 3078  
Phone: +61 3 9555 3522  
Associated Dealer: Trivett Classic Aston Martin Melbourne

---

**Cat B Glenelg Crash Repairs**

---

222 Brighton Road, Somerton Park, South  
Phone: +61 (0)3 9415 8181  
Associated Dealer: Solitaire Aston Martin

---

**Cat A Gosney's**

---

4 Anne Street, Southport, Gold Coast, Queensland 4215  
Phone: 0061 7 5532 3166  
Associated Dealer: Southport Motors

---

**Cat B Lombardi Brothers**

---

11 Charles Street, Bentley, Perth, Western Australia, 6106  
Phone: +00 61 89356-1013  
Associated Dealership: Barbagallo Aston Martin

## Austria

---

**Cat A Dingl Christian**

---

Wiener Strasse 28, 7052 Muellendorf  
Phone: 0043268263822  
Associated Dealership: Aston Martin Vienna

---

**Cat B Kuhleitner, Karosserie - Spenglerei Kühleitner**

---

5020 Salzburg, Samergasse 23  
Phone: 0043 662 - 87 4 377  
Associated Dealership: Aston Martin Salzburg



## Belgium

---

**Cat B** **Carroserie Adriaenssens**

---

Rijksweg 55, 2870 Nuurs  
Phone: 031 886 6368  
Associated Dealership: Aston Martin Belgium

---

**Cat B** **Carrosserie Van Den Eede H & B**

---

Brandstraat 31, 2800 Willebroek  
Phone: 0032 3 886 78 49  
Associated Dealership: Aston Martin Belgium

## Canada

---

**Cat A** **Auto Bugatti**

---

11355 Cote de Liesse, Dorval, Quebec H9P 1B2  
Phone: 001 514 636 7818  
Associated Dealership: Decarie Motors

---

**Cat B** **Burrard Autostrasse Collision Ltd.**

---

2185 Pine Street, Vancouver B.C.  
Phone:  
Associated Dealership: MCL Motor Cars

---

**Cat B** **Grand Touring Collision Centre**

---

1214 Caledonia Road, Toronto, Ontario  
Phone: 001 416 783 3327  
Associated Dealership: Aston Martin of Ontario

## China

---

**Cat A** **Aston Martin Beijing**

---

No 1 Jing Gang Lu, Jin Zhan Xiang, Chao Yang District, Beijing, 100018  
Phone:  
Associated Dealership: Aston Martin Beijing

---

**Cat A** **Aston Martin Shanghai Body Shop**

---

Shanghai Richcom Traffic Equipment Lease Service Co. Ltd., 8685 Zhong Chun Road, Shanghai, 201101  
Phone: 021-34100442  
Associated Dealership: Aston Martin Shanghai

## Denmark

---

**Cat B** **Brdr Elkjær**

---

Hejrevej 33, 2400 København NV  
Phone: 0045 38 10 45 40  
Associated Dealership: Aston Martin Denmark

---

**Cat B** **Das Karrosseri**

---

Krondalvej 11, 2610 Rødovre  
Phone: 0045 44 84 84 85  
Associated Dealership: Aston Martin Denmark

## Dubai

---

**Cat A** **Al Habtoor**

---

PO Box 19879, Dubai, UAE  
Phone: 00971 4 691110  
Associated Dealership: Al Habtoor

## England

---

**Cat B** **Abridge Body Centre**

---

Abridge Body Centre Langston Road, Loughton, Essex, IG10 3TQ  
Phone: 07818016350  
Associated Dealership: Lancaster Seven Oaks

---

**Cat B** **Ambassador Car Recovery Ltd.**

---

Unit 6, Forsyth Road, Woking, Surrey, GU21 5SB  
Phone: 01483 747752  
Associated Dealership: HWM

---

**Cat A** **Aston Martin Works Service**

---

Tickford Street, Newport Pagnell, MK16 9AN  
Phone: 01908 619264  
Associated Dealership: ASTON MARTIN

---

**Cat B** **Autobody Care**

---

104 Gelderd Road, Leeds, LS 12 6BY  
Phone: 0113 257 2000  
Associated Dealership: JCT 600 Leodis Court

---

**Cat B** **Balgores Motors**

---

1 Bryant Avenue, Romford, Essex, RM3 0AP  
Phone: 01708 344122  
Associated Dealership: Grange Aston Martin

---

**Cat B** **BlueBell Bodyshop**

---

Brooke Park, Lower Meadow Road, Handforth, Cheshire, SK 9 3LP  
Phone: 0161 486 2080  
Associated Dealership: Stratstone of Wilmslow

---

**Cat B** **Bodytechnics Ltd.**

---

381 Sykes Road, Trading Estate, Slough, Berkshire, SL1 4SP  
Phone: 01753 505900  
Associated Dealership: Aston Martin Sales of Mayfair

---

**Cat A** **Chartwell Bodycraft Chartwell Ltd.**

---

Chartwell House, 1 Brunel Parkway, Derby, DE24 8HR  
Phone: 01332 340972  
Associated Dealership: Paramount Derby

---

**Cat B** **Chiltern Aston Centre**

---

Leyhill Road, Bovingdon, Hertfordshire, HP3 0NW  
Phone: 01442 833177  
Associated Dealership: Chiltern Aston Centre

---

**Cat B** **City Centre Car Care Co.**

---

260 Bradford Street, Digbeth, Deritend, Birmingham, B12 0QY  
Phone: 0121 766 7699  
Associated Dealership: Stratstone Birmingham

---

**Cat B** **Cougar Direct**

---

Crescent Road, Luton, Bedfordshire, LU2 0AR  
Phone: 01582 540900  
Associated Dealership: Grange Aston Martin Welwyn

---

**Cat B** **Davies Motor Company Ltd.**

---

Hadfield Close, Leckwith, Cardiff, CF11 8BD  
Phone: 029 20394407  
Associated Dealership: Stratstone Cardiff

---

**Cat B** **DLC Cars**

---

1 - 11 St Georges Road, Reading, Berkshire, RG30 2RG  
Phone: 01189 505004  
Associated Dealership: Lancaster Reading

---

**Cat A** **Evans Halshaw Bodycare Centre**

---

Hepburn Gardens, Felling, Gateshead, NE10 0AD  
Phone: 0191 495 4300  
Associated Dealership: Aston Martin Houghton Le Spring

---

**Cat A** **Fairweather Autoshine**

---

Vulcan Works, Water Lane, Exeter, EX2 8BY  
Phone: 01392 420000  
Associated Dealership: Grange of Exeter

---

**Cat B** **Harwoods**

---

Seven Oaks Billingham, West Sussex, RH14 9AZ  
Phone: 01403 787020  
Associated Dealership: Harwoods

**Cat B JCT600 Body Clinic**

320 Sticker Lane, Bradford, BD4 8RS  
 Phone: 01274 778600  
 Associated Dealership: JCT 600 Leodis Court

**Cat B Lancaster Cambridge Body Centre**

High St, Harston, Cambridge, CB2 5QE  
 Phone: 01223 872872  
 Associated Dealership: Lancaster Cambridge

**Cat B Lloyds Autobody**

Unit 11, Ringway Trading Estate, Shadowmoss Road,  
 Wythenshawe, Manchester, M22 5LH  
 Phone: 0161 437 9911  
 Associated Dealership: Stratstone of Wilmslow

**Cat B MKG Accident Repair Centres**

Cavendsh Road, Stevenage, Herts, SG1 2ET  
 Phone: 01438 720720  
 Associated Dealership: Grange Aston Martin Welwyn

**Cat A Panelwise of Weybridge**

The Latehouse, Hamm Moor Lane, Weybridge Business Park,  
 Surrey, KT15 2SD  
 Phone: 01932 856460  
 Associated Dealership: HWM

**Cat A Stratstone Body Repair Centre**

Unit 11, Hayes Trading Estate, Hingley Road, Lye, Stourbridge,  
 B63 2RR  
 Phone: 01384 426070  
 Associated Dealership: Stratstone Birmingham

**Cat A Stratton Motor Company**

Ipswich Road, Long Stratton, Norwich, NR15 2XJ  
 Phone: 01508 530491  
 Associated Dealership: Stratton Motor Company

**Cat B The Autoshop Accident Repair Centre Ltd.**

Unit 22, Hopemills Industrial Park, London Road, Briscombe,  
 Stroud, GL5 2SE  
 Phone: 01453 882844  
 Associated Dealership: Broughtons Aston Martin

**Cat B Tonbridge Repair Centre**

Units 8-9 Cannon Bridge works, Cannon Lane, Tonbridge, Kent  
 TN9 1PP  
 Phone: 01732 771117  
 Associated Dealership: Lancaster Seven Oaks

## France

<b>Cat A</b>	<b>Aston Martin Paris</b>
	6-10 rue de la Cavalerie, 75015, Paris Phone: 0033 1 53 86 7272 Associated Dealership: Aston Martin Paris
<b>Cat B</b>	<b>Carrosserie de Los Angeles</b>
	10, rue de Breteil, 33320 Eysines Phone: 0033 556 28 52 17 Associated Dealership: Aston Martin Bordeaux

## Germany

<b>Cat A</b>	<b>Alfred Krauthahn GmbH</b>
	Nestorstrasse 27-29, D-10709 Berlin-Wilmersdorf Phone: 0049 30 896 000 31 Associated Dealership: Krauthahn Berlin
<b>Cat B</b>	<b>Autolackierung Dominante GmbH</b>
	Grosser Haingraben 9, 65779 Kelkheim Phone: 0049 619 5 67477 Associated Dealership: Autohaus Kronberg
<b>Cat B</b>	<b>Bündesmann</b>
	Suitbertusstrabe 81, 40223, Düsseldorf Phone: 0049 02131 9227 36 Associated Dealership: Moll GmbH
<b>Cat B</b>	<b>Ellerbrock GmbH</b>
	Rudolf Diesel Strasse 2, 28816 Stuhr Phone: 0049 421870181 Associated Dealership: Tamsen Bremen

<b>Cat B</b>	<b>FA Heller GmbH</b>
	Sandhoferstr, 199-201, 68307 Mannheim Phone: 0049 621 772317 Associated Dealership: Kroymans Autohaus Mannheim GmbH
<b>Cat B</b>	<b>Gerrards KG + Sohn</b>
	Adalbertsteinweg 220, 52066 Aachen Phone: 0049 241 501168 Associated Dealership: L Hauswirth Exclusive Car GmbH
<b>Cat A</b>	<b>Preisacher Unfallinstandsetzung</b>
	Hirschbachweg 9c, 85659 Forstern, Munich Phone: 0049 81 24 / 7015 Associated Dealership: Autohaus Avalon München GmbH
<b>Cat B</b>	<b>Premiumcars Peters</b>
	Phone: 0049 231 91204048 Associated Dealership: Aston Martin Dortmund

## Hong Kong

---

**Cat B Schwabengarage AG Stuttgart**

---

Cannstatter Strasse 46, 70190 Stuttgart  
 Phone: 0711 2803 2400  
 Associated Dealership: Schwabengarage AG

---

**Cat B Aspelohe**

---

36 22848 Norderstedt  
 Phone: 0049 40 5234767  
 Associated Dealership: Tamsen Hamberg

---

**Cat A Shun Hing Motor**

---

Phone:  
 Associated Dealership: Aston Martin (HK) Ltd.

## Italy

---

**Cat B Csrrozeria Vigentina SNC**

---

Via Rutilia 10/8 20141 Milano  
 Phone: 0039 02/56810266  
 Associated Dealership: Milan

---

**Cat A F.lli De Clementi & Snc**

---

Carrozeria Autorizzata, Via Fiano, 14, 00191 Rome  
 Phone: 0039 63333309  
 Associated Dealership: Aston Martin Rome

---

**Cat A New Car Carrozeria**

---

New Car srl, 35027 Noventa Padovana (PD), Via Noventa  
 Phone: 00394 989 59103  
 Associated Dealership: Padova

## Japan

<b>Cat A</b>	<b>Ace Auto Service Co. Ltd.</b> Showajima Centre, 5-18 Showajima 1 Chome, Ohta-Ku, Tokyo 143-0004 Phone: 0081 3 5493 2345 Associated Dealership: Atlantic Cars Limited
<b>Cat A</b>	<b>B-Right co, Ltd.</b> 4-23 Meiboku-cho, Torikai, Settsu-City, Osaka 566-0063 Phone: 0081 72 653 5341 Associated Dealership: Aston Martin Akasaka
<b>Cat B</b>	<b>Hakko Jidosha Co. Ltd.</b> 4-8-35, Takaitanaka, Higashi-Osaka-Shi, Osaka Hakko Jidosha Co., Ltd. Phone: 0081 6-6783-3401 Associated Dealership: Aston Martin Osaka Hakko
<b>Cat B</b>	<b>IM Corporation Ltd.</b> 1-27-31 Kitamikata, Takatsu-ku, Kawasaki-shi, Kanagawa Phone: 0081 44833 1288 Associated Dealership: Aston Martin Akasaka

## Kuwait

<b>Cat B</b>	<b>Run and Run</b> 2-226, Takasu, Sango-Shi, Saitama Phone: 0081 48-955-8381 Associated Dealership: Atlantic Cars Limited
<b>Cat B</b>	<b>Showa Jidosha Co</b> 303 -1, Irukadeshinden, Komaki-shi, Aichi, 485-0084 Phone: 0081 568 72 3718 Associated Dealership: Aston Martin Nagoya

<b>Cat A</b>	<b>Aston Martin Kuwait</b> Phone: Associated Dealership: Aston Martin Kuwait
--------------	--

## Lebanon

---

Cat B	Chawa Fares
	Honda Building, Chouran Unesco, PO Box 11-5800, Riad El Soih 11072000, Beirut Phone: 00961 180001 Associated Dealership: MANA Automotive

## Monaco

---

Cat A	Carrosserie Jourdan
	100 Val du Carei, 06500 Menton Phone: 0033 493 35 94 00 Associated Dealership: British Motors

## Netherlands

---

Cat A	Autoschade Groeneveld B.V
	ESP 200, 5633 AC Eindhoven Phone: 0031 402424546 Associated Dealership: Cito Motors

Cat A	Boschman Autoschade
	Reggestraat 29, 5347 JG Oss Phone: 0031 412 650649 Associated Dealership: Kroymans Aston Martin B.V.



## New Zealand

---

---

**Cat A** **Evans European**

---

353 Church Street, Penrose, Auckland  
Phone: 0064 9 636 5004  
Associated Dealership: Independent Prestige Limited

---

**Cat B** **Precision AutoWerk**

---

224 Archers Road, Glenfield, Auckland  
Phone: 0064 9 443 2432  
Associated Dealership: Independent Prestige Limited

## Northern Ireland

---

---

**Cat A** **Charles Hurst ARC**

---

The Cutts, Derrriaghy Ind Est, Donmurray, Northern Ireland BT17 9HN  
Phone: 02890 615856  
Associated Dealership: Charles Hurst

## Norway

---

---

**Cat B** **Ullern Bil Skade AS**

---

STALFJAERA 12, N - 0975 Olso  
Phone: (+47) 24173050  
Associated Dealership: AS INSIGNIA

## Portugal

---

---

**Cat A** **AML Sport SA**

---

Av. 25 de Abril, Lt. 120, Massamá, 2745-864 Queluz  
Phone: 00351 21 430 97 00  
Associated Dealership: AML Sport SA

---

**Cat B** **Castro E Cruz**

---

Rua Avelino Sagado De Oliveira, 13-A 2680-104 Camarate  
Phone: 0035 1219474734  
Associated Dealership: AML Sport SA

## Russia

---

---

**Cat B** **SportCar-Center**

---

Abramtsevsкая 30, 127572, Moscow  
Phone:  
Associated Dealership: AM Moscow

## Saudi Arabia

---

---

**Cat A** **Haji Husein Alireza**

---

Al Khobar  
Phone: 966 3 8588 800  
Associated Dealership: Haji Husein Alireza

## Singapore

---

**Cat A** **Tabernacle Auto Services PTE Ltd.**

---

41 Kian Teck Drive, Singapore, 628855  
Phone: (65) 6268 6571  
Associated Dealership: Aston Martin SEA

## South Africa

---

**Cat A** **Renew-It Autobody**

---

19 Old Main Pretoria Road, Marlboro, Sandton, PO Box 784907,  
Sandton 2146  
Phone: 011 444 6390  
Associated Dealership: Aston Martin Sandton

## Spain

---

**Cat A** **C De Salamanca SA Madrid**

---

C/ Zurbano, 93-95, Madrid 28003  
Phone: 0034 915 548293  
Associated Dealership: C De Salamanca SA Marbella

---

**Cat B** **C De Salamanca SA Marbella**

---

Marbella Carretera de Cádiz KM 171, 29670 San Pedro de  
Alcántara, Marbella  
Phone: 0034 669 44 77 01  
Associated Dealership: C De Salamanca SA

---

**Cat A** **Central Reparacion Carrocerias**

---

Quadis Autocentre Maresme, Ctra. Nacional II, Km. 643, 08349  
Cabrera de Mar  
Phone: 0034 93 741 80 15  
Associated Dealership: Aston Martin Barcelona

## Switzerland

**Cat A Carroserie M Bellido**  
42A Route de Satigny, 1217 Meyrin, Geneva  
Phone: 0041 227823290  
Associated Dealership: Garage P Keller SA

**Cat A Emil Frey AG**  
Industrie Nord, Autocentre, 5745 Safenwil  
Phone: 0041 62 788 8888  
Associated Dealership: Emil Frey AG

**Cat A Garage Tarcisio Pasta SA**  
Via San Gottardo 47, 6828 BALERNA  
Phone: 0041 31 6358500  
Associated Dealership: Garage Tarcisio Pasta SA

## USA

**Cat A Amato's Autobody Inc.**  
3848 Sorrento Valley Blvd, San Diego, CA 92121  
Phone: 001 858 455 6715  
Associated Dealership: Aston Martin of San Diego

**Cat A Aston Martin of Troy**  
85 Linden Street, Waltham, MA 02452  
Phone: 001 248-614-3181  
Associated Dealership: Aston Martin of Troy

**Cat A Aston Martin Tysons**  
8545 Leesburg Pike, Vienna VA 22182  
Phone: 001-703-790-3220  
Associated Dealership: Aston Martin Tysons

**Cat B Avio Coach Craft**  
2245 Pontius Avenue, W. Los Angeles, CA 90064  
Phone: 001 31 0312 1128  
Associated Dealership: Aston Martin of Beverly Hills

**Cat B Barsotti's**  
75 Mill Street, San Rafael, CA 94901  
Phone: 001 415 454-5157  
Associated Dealership: Aston Martin Marin

**Cat A Bell Red Auto Rebuild**  
1406 130th Avenue NE, Bellevue, Washington 98005  
Phone: 001 425-453-5552  
Associated Dealership: Aston Martin Seattle

**Cat A Brook's Motorcars**  
9829 Bigge Street, Oakland, CA, 94603  
Phone: 001 (510) 632-8901  
Associated Dealership: Cole European

**Cat A Countach - Auto Ref. & Coach Work**  
111 San Lorenzo, Coral Gables, FL 33146, Florida  
Phone: 001 305 443 1468  
Associated Dealership: The Collection

---

**Cat B Dayas Custom Autos Inc.**

---

800 Bennet Drive, Longwood, Florida 32750  
Phone: 001 407 3315599  
Associated Dealership: Aston Martin Orlando

---

**Cat B DC Autocraft**

---

25/57 East Providencia Avenue, Burbank, California, 91502  
Phone: 001 818846 5032  
Associated Dealership: Galpin Aston Martin

---

**Cat B Dell Auto Body**

---

950 Camden Avenue, Campbell, CA 95008  
Phone: 001 408 370 0189  
Associated Dealership: Aston Martin Silicon Valley

---

**Cat A European Motor Car Works**

---

2923 Tech Center Drive, Santa Ana, California 92705  
Phone: 001 714 957 1290  
Associated Dealership: Bauer Aston Martin

---

**Cat A Exoticar Paintworks Inc.**

---

2901 S Highland, Building 9E, Las Vegas, Nevada 89109  
Phone: 001 702 733 1859  
Associated Dealership: Gaudin Aston Martin of Las Vegas

---

**Cat A First Class**

---

2412 NE 5th Avenue, Pompano Beach, FL 33064  
Phone: 001 954 785 3784  
Associated Dealership: Aston Martin Palm Beach

---

**Cat A Flower Hill Auto Body Inc.**

---

12 Middle Neck Road, Roslyn, NY 11576  
Phone: 001 516 627 3913  
Associated Dealership: Miller Motor Cars - Long Island

---

**Cat A Global Collision**

---

5101 East Evans Avenue, Denver, Colorado 80222  
Phone: 001 303 762 7562  
Associated Dealership: Sill-Terhar Aston Martin

---

**Cat A Harry's Auto Collision Center**

---

1013 South La Brea Avenue, Los Angeles, California 90019  
Phone: 001 323 933 4600  
Associated Dealership: Aston Martin of Beverly Hills

---

**Cat A Hollis Auto Body Inc.**

---

230 Eliot Street, Ashland, MA 01721  
Phone: 001 508 881 1990  
Associated Dealership: Aston Martin New England

---

**Cat A Inter-Pro Autobody Inc.**

---

417 W Washington Av, Lake Bluff IL 60044  
Phone: 001 847-295-1222  
Associated Dealership: Lake Forest

---

**Cat A J & B Bodywerks**

---

36 - 38 Beach St, Mt Vernon, NY 10550  
Phone: 001 914 664 8080  
Associated Dealership: Miller Motor Cars

---

**Cat A Jacks Body Works Inc.**

---

68350 Commercial Road, Cathedral City, CA 92234  
 Phone: 001 760 321 4752  
 Associated Dealership: Desert European Motor Cars Ltd.

---

**Cat A John Eagle Collision Centre**

---

6125 Peeler Street, Dallas, Texas, USA  
 Phone: 001 214 353 3570  
 Associated Dealership: Aston Martin Dallas

---

**Cat A Katy Coach Works Inc.**

---

1180 Blalock Road, Houston, Texas 77055  
 Phone: 001 713 465 6225  
 Associated Dealership: Star Motor Cars

---

**Cat A Magnum Collision Repair Centre**

---

1445 Field Park Cir., Marietta, Georgia 30066  
 Phone: 001 770 427-4590  
 Associated Dealership: Aston Martin of Atlanta

---

**Cat A Quality Autobody**

---

811 New Bruswick Avenue, Rahway, New Jersey 07065  
 Phone: 001 732 388 2400  
 Associated Dealership: F C Kerbeck Aston Martin

---

**Cat B R&S Auto Body Inc.**

---

4102 N Armenia Avenue Tampa, Florida 33607  
 Phone: 001 813-876-1913  
 Associated Dealership: Aston Martin of Tampa Bay

---

**Cat B Scotsdale Paint and Body**

---

350 N. Hayden Road, Scotsdale, AZ 85257  
 Phone: 001 480 421 8800  
 Associated Dealership: Scottsdale Aston Martin

---

**Cat B True Performance**

---

7854 Industrial Parkway, Plain City, Ohio 43064  
 Phone: 001 614 733 0708  
 Associated Dealership: Midwestern Auto Group

## Scotland

---



---

**Cat A JM Accident Repair Centre**

---

Frairton Bridge Park, Frairton Road, Perth, Scotland, PH2 8DD  
 Phone: 01738 626262  
 Associated Dealership: Murray Aston Martin

# Authorised Service Centres

England.....E.2



## England

---

---

### Aston Workshop

---

Red Row, Beamish, County Durham, DH9 ORW, United Kingdom.

Phone: +44 (0) 1207 233525

Fax: +44 (0) 1207232202

---

### Chiltern Aston Centre Ltd

---

Ley Hill Road, Bovington, Hemel Hempstead, Hertfordshire, HP3 0NW, United Kingdom.

Phone: +44 (0) 1442 833177

Fax: +44 (0) 1442 834800

---

### North One Service Centre

---

Unit 5, Bush Industrial Estate, Station Road, Tufnell Park, London, N19 5UN, United Kingdom.

Phone: +44 (0) 207 837 2000

Fax: +44 (0) 207 837 2111



ASTON MARTIN



# Dealer Directory

Introduction .....	F.2	England.....	F.7	Poland .....	F.18
Australia .....	F.2	France.....	F.10	Portugal .....	F.18
Austria.....	F.3	Germany.....	F.10	Russia .....	F.18
Belgium.....	F.4	Holland.....	F.13	Scotland.....	F.19
Canada .....	F.4	Hong Kong.....	F.13	Singapore.....	F.19
Channel Islands .....	F.5	Italy.....	F.14	South Africa .....	F.19
Chile .....	F.5	Japan .....	F.14	Spain .....	F.20
China .....	F.5	Middle East.....	F.15	Sweden.....	F.20
Croatia .....	F.6	Monaco .....	F.16	Switzerland.....	F.21
Czech Republic.....	F.6	New Zealand .....	F.17	Taiwan.....	F.21
Denmark.....	F.6	Northern Ireland .....	F.17	United States of America.....	F.22
		Norway.....	F.17	Wales .....	F.27

## Introduction

---

This section lists all Aston Martin Dealers worldwide, where sales and service are provided by companies with the facilities, knowledge and factory trained personnel.

Every effort has been made to make sure that the information provided in the Dealer Directory is accurate and up-to-date. However changes amongst holders of the Aston Martin franchise may occur. Neither Aston Martin nor any listed Importer or Dealer shall in any circumstances be held liable for any inaccuracy, or the consequences thereof.

Dealers listed here all aim to conform to Aston Martin standards of excellence in both sales and service. However, all vehicles sold as Aston Martins are required to meet local legislation requirements.

Should service be required in a country other than that in which this vehicle was originally purchased, every effort will be made to meet the owner's requirements, but the availability of certain parts may be affected by differences in vehicle and component specifications.

If the nearest Aston Martin Dealer is unable to help, contact Aston Martin directly:

### **Aston Martin Lagonda Limited**

Banbury Road, Gaydon, WARWICK, CV35 0DB

Telephone: (+44) (0)1926 644300

Facsimile: (+44) (0)1926 644733

Web Site: [www.astonmartin.com](http://www.astonmartin.com)

E-Mail: [enquiries@astonmartin.com](mailto:enquiries@astonmartin.com)

Aston Martin Dealers are independent traders, they are not the Company's Agents, and therefore have no authority to bind the Company or to enter into any financial or other commitments on the Company's behalf.

Only Aston Martin Dealers are authorised to carry out warranty work.

## Australia

---

### **Adelaide**

---

#### **Solitaire Aston Martin**

32 Belair Rd., Hawthorn, Adelaide, SA 5062

Telephone: (+61) 8 8152 5100

Facsimile: (+61) 8 8152 5120

Web Site: [www.solitaire.com.au](http://www.solitaire.com.au)

E-Mail:

### **Perth**

---

#### **Barbagallo Aston Martin**

354 Scarborough Beach Rd., Osborne Park, Perth, WA 6017

Telephone: (+61) 8 9231 5999

Facsimile: (+61) 8 9242 3717

Web Site: [www.barbagallo.com.au](http://www.barbagallo.com.au)

E-Mail: [astonmartin@barbagallo.com.au](mailto:astonmartin@barbagallo.com.au)

---

## Queensland

---

### Sunshine Aston Martin

179 Nerang Rd., Southport, Queensland, 4215

Telephone: (+61) 7 5582 7888

Facsimile: (+61) 7 5532 3361

Web Site: [www.sunshineastonmartin.com.au](http://www.sunshineastonmartin.com.au)

E-Mail: [sales@sunshineastonmartin.com.au](mailto:sales@sunshineastonmartin.com.au)

---

## Sydney

---

### Trivett Classic Garage Pty. Ltd.

32–38 Yurong St., East Sydney, NSW 2010

Telephone: (+61) 2 8338 3993

Facsimile: (+61) 2 8338 2169

Web Site: [www.astonmartinsydney.com.au](http://www.astonmartinsydney.com.au)

E-Mail: [astonmartin@trivett.com.au](mailto:astonmartin@trivett.com.au)

---

---

## Victoria

---

### Trivett Classic Aston Martin Melbourne

80 City Road, Southbank, Victoria 3006

Telephone: (+61) 3 8866 3111

Facsimile: (+61) 3 8866 3100

Web Site: [www.astonmartinmelbourne.com.au](http://www.astonmartinmelbourne.com.au)

E-Mail: [astonmartinmelbourne@trivett.com.au](mailto:astonmartinmelbourne@trivett.com.au)

---

---

## Austria

---

---

## Salzburg

---

### Aston Martin Salzburg

Wasserfeldstraße 17a, 5020 Salzburg

Telephone: (+43) 662 887 8820

Facsimile: (+43) 662 887 882 88

Web Site: [www.astonmartin.at](http://www.astonmartin.at)

E-Mail: [salzburg@astonmartin.at](mailto:salzburg@astonmartin.at)

---

## Vienna

---

### Aston Martin Wien

Motorcity SCS, Autoallee 7, 2334 Vosendorf b. Wien

Telephone: (+43) 1 698 1200 0

Facsimile: (+43) 1 698 1200 88

Web Site: [www.astonmartin.at](http://www.astonmartin.at)

E-Mail: [wien@astonmartin.at](mailto:wien@astonmartin.at)

---

## Belgium

---

### Antwerp

---

#### Aston Martin Antwerp

Autolei 322, 2160 Wommelgem

Telephone: (+32) (0) 3 354 3856

Facsimile: (+32) (0) 3 354 5867

Web Site: [www.astonmartin-antwerp.com](http://www.astonmartin-antwerp.com)

E-Mail: [info@astonmartin-antwerp.com](mailto:info@astonmartin-antwerp.com)

---

### Brussels

---

#### Aston Martin Brussels NV-SA

Borrestraat 23, St. Stevens-Woluwe, 1932

Telephone: (+32) (0) 2720 4345

Facsimile: (+32) (0) 2720 8474

Web Site: [www.astonmartin-brussels.com](http://www.astonmartin-brussels.com)

E-Mail: [info@astonmartin-brussels.com](mailto:info@astonmartin-brussels.com)

---

## Canada

---

### Alberta

---

#### Aston Martin Calgary

150 Glendeer Circle SE, Calgary, Alberta, T2H 2V4

Telephone: (+1) 403 648 4755

Facsimile: (+1) 403 648 0056

Web Site: [www.astonmartincalgary.ca](http://www.astonmartincalgary.ca)

E-Mail:

---

### British Columbia

---

#### MCL Motor Cars (1992) Inc.

1820 Burrard St., Vancouver, British Columbia, V6J 3H1

Telephone: (+1) 604 733 1820

Facsimile: (+1) 604 733 1828

Web Site: [www.astonmartinvancouver.com](http://www.astonmartinvancouver.com)

E-Mail: [sales@mclmotorcars.com](mailto:sales@mclmotorcars.com)

---

### Ontario

---

#### Aston Martin of Ontario

740 Dupont St., Toronto, Ontario, M6G 1Z6

Telephone: (+1) 416 530 1880

Facsimile: (+1) 416 530 4495

Web Site: [www.astonmartinofontario.com](http://www.astonmartinofontario.com)

E-Mail: [sales@grandtouringautos.com](mailto:sales@grandtouringautos.com)

---

### Quebec

---

#### Decarie Motors

8255 Bougainville, Montreal, Quebec, H4P 2T3

Telephone: (+1) 514 334 9910

Facsimile: (+1) 514 336 0548

Web Site: [www.decarie.com](http://www.decarie.com)

E-Mail: [sales@decarie.com](mailto:sales@decarie.com)

---

## Channel Islands

---

### Jersey

---

#### Jacksons (CI) Ltd.

La Rue Fondon, St. Peter, Jersey, JE3 7BF

Telephone: (+44) (0) 1534 497777

Facsimile: (+44) (0) 1534 497729

Web Site: [www.jacksonsci.com](http://www.jacksonsci.com)

E-Mail: [astonmartin@jacksons.je](mailto:astonmartin@jacksons.je)

## Chile

---

### Santiago

---

#### Aston Martin Santiago

Padre Hurtado Norte No. 1602, Vitacura, Santiago 7650191

Telephone:

Facsimile:

Web Site:

E-Mail:

## China

---

### Beijing

---

#### Aston Martin Beijing

No 1 Jing Gang Lu, Chao Yang District, 100018

Telephone: (+86) 10 8433 3007

Facsimile: (+86) 10 8433 3737

Web Site: [www.astonmartin-china.com](http://www.astonmartin-china.com)

E-Mail:

### Shanghai

---

#### Aston Martin Shanghai

No 1 Hua Fu Tian Di, 222 Alley, Madang Lu, Luwan District

Telephone: (+86) 21 6387 6007

Facsimile: (+86) 21 6387 3007

Web Site: [www.astonmartin-china.com](http://www.astonmartin-china.com)

E-Mail:

## Croatia

---

### Zagreb

---

#### Aston Martin Zagreb

Radnička 37b, Zagreb

Telephone: (+385) 1 6410 500

Facsimile: (+385) 1 6410 501

Web Site: [www.astommartinzagreb.hr](http://www.astommartinzagreb.hr)

E-Mail: [info@astonmartinzagreb.hr](mailto:info@astonmartinzagreb.hr)

## Czech Republic

---

### Prague

---

#### Aston Martin Prague

Èeskomoravská 183, Prague

Telephone: (+420) 272 040 007

Facsimile: (+420) 284 680 115

Web Site: [www.astonmartinpraha.cz](http://www.astonmartinpraha.cz)

E-Mail: TBA

## Denmark

---

### Copenhagen

---

#### Aston Martin Denmark

Bryggervangen 39, PO 2630, DK-2100, Copenhagen Ø

Telephone: (+45) 369 00 945

Facsimile: (+45) 392 72 250

Web Site: [www.aston-martin.dk](http://www.aston-martin.dk)

E-Mail: [hsw@astonmartin.dk](mailto:hsw@astonmartin.dk)

# England

---

## Berkshire

---

### Lancaster Reading

Bennet Rd., Reading, Berkshire, RG2 0QX

Telephone: (+44) (0)118 9658500

Facsimile: (+44) (0)118 9658501

Web Site: [www.lancasterplc.com](http://www.lancasterplc.com)

E-Mail: [astonmartin@reading.jardinemotors.co.uk](mailto:astonmartin@reading.jardinemotors.co.uk)

---

## Buckinghamshire

---

### Aston Martin Lagonda Limited

Works Service, Tickford St., Newport Pagnell, MK16 9AN

Telephone: (+44) (0)1908 619264

Facsimile: (+44) (0)1908 216439

Web Site: [www.astonmartin.com](http://www.astonmartin.com)

E-Mail: [service2@astonmartin.com](mailto:service2@astonmartin.com)

---

### Stratstone of Amersham

44 Woodside Rd., Amersham, Buckinghamshire, HP6 6AJ

Telephone: (+44) (0)1494 788360

Facsimile: (+44) (0)1494 788379

Web Site: [www.stratstone.com](http://www.stratstone.com)

E-Mail: [amershamastonmartin@stratstone.com](mailto:amershamastonmartin@stratstone.com)

---

## Cambridgeshire

---

### Lancaster Cambridge

High St., Harston, Cambridge, CB22 7TN

Telephone: (+44) (0)870 410 3848

Facsimile: (+44) (0)1223 875675

Web Site: [www.lancasterplc.com](http://www.lancasterplc.com)

E-Mail: [astonmartin@cambridge.jardinemotors.co.uk](mailto:astonmartin@cambridge.jardinemotors.co.uk)

---

## Cheshire

---

### Stratstone of Wilmslow

Water Lane, Wilmslow, SK9 5BQ

Telephone: (+44) (0)1625 548802

Facsimile: (+44) (0)1625 526873

Web Site: [www.stratstone.com](http://www.stratstone.com)

E-Mail: [wilmslowastonmartin@stratstone.com](mailto:wilmslowastonmartin@stratstone.com)

---

## Derbyshire

---

### Stratstone Aston Martin Derby

Sir Frank Whittle Rd., Derby, DE21 4LT

Telephone: (+44) (0)1332 258796

Facsimile: (+44) (0)1332 258799

Web Site: [www.stratstone.com](http://www.stratstone.com)

E-Mail: [derbyastonmartin@stratstone.com](mailto:derbyastonmartin@stratstone.com)

---

---

**Devon**

---

**Grange of Exeter**

Yeoford Way, Exeter, EX2 8LB

Telephone: (+44) (0)1392 678044

Facsimile: (+44) (0)1392 678048

Web Site: [www.grange.co.uk](http://www.grange.co.uk)E-Mail: [grangeastonmartinexeter@grange.co.uk](mailto:grangeastonmartinexeter@grange.co.uk)

---

**Essex**

---

**Grange of Brentwood**

2 Brook St., Brentwood, CM14 5LU

Telephone: (+44) (0)1277 249555

Facsimile: (+44) (0)1277 249556

Web Site: [www.grange.co.uk](http://www.grange.co.uk)E-Mail: [grangeastonmartin.brentwood@summitautogroup.co.uk](mailto:grangeastonmartin.brentwood@summitautogroup.co.uk)

---

---

**Gloucestershire**

---

**Broughtons Aston Martin**

Rutherford Way, Cheltenham, GL51 9SQ

Telephone: (+44) (0)1242 232667

Facsimile: (+44) (0)1242 232668

Web Site: [www.broughtons.co.uk](http://www.broughtons.co.uk)E-Mail: [info@broughtonsastonmartin.co.uk](mailto:info@broughtonsastonmartin.co.uk)

---

**Hertfordshire**

---

**Grange of Welwyn**

Great North Rd., Stanborough, Welwyn Garden City AL8 7TQ

Telephone: (+44) (0)1707 280868

Facsimile: (+44) (0)1707 280869

Web Site: [www.grange.co.uk](http://www.grange.co.uk)E-Mail:

---

---

**Kent**

---

**Lancaster Sevenoaks**

114 - 115 London Rd., Sevenoaks, TN13 2DN

Telephone: (+44) (0)844 668 0138

Facsimile: (+44) (0)1732 465566

Web Site: [www.lancasterastonmartin.co.uk](http://www.lancasterastonmartin.co.uk)E-Mail: [astonmartin@sevenoaks.jardinemotors.co.uk](mailto:astonmartin@sevenoaks.jardinemotors.co.uk)

---

**London**

---

**Stratstone of Mayfair**

Brook House, Park Lane, London, W1K 7AJ

Telephone: (+44) (0)20 7235 8888

Facsimile: (+44) (0)20 7629 5376

Web Site: [www.stratstone.com](http://www.stratstone.com)E-Mail: [mayfairastonmartin@stratstone.com](mailto:mayfairastonmartin@stratstone.com)

---



---

**Norfolk**

---

**Stratton Motor Company (Norfolk) Limited**

Ipswich Rd., Long Stratton, Norwich, NR15 2XJ

Telephone: (+44) (0)1508 530491

Facsimile: (+44) (0)1508 531670

Web Site: [www.strattonmotorcompany.com](http://www.strattonmotorcompany.com)E-Mail: [astonsales@strattonmotorcompany.com](mailto:astonsales@strattonmotorcompany.com)

---

**Surrey**

---

**HWM Aston Martin**

New Zealand Ave., Walton on Thames, KT12 1AT

Telephone: (+44) (0)1932 233196

Facsimile: (+44) (0)1932 225440

Web Site: [www.hwmastonmartin.co.uk](http://www.hwmastonmartin.co.uk)E-Mail: [sales@hwm.co.uk](mailto:sales@hwm.co.uk)

---

---

**Tyne and Wear**

---

**Stratstone Tyne and Wear**

Stoneygate, Houghton le Spring, Tyne and Wear, DH4 4NJ

Telephone: (+44) (0)191 512 3512

Facsimile: (+44) (0)191 512 3509

Web Site: [www.stratstone.com](http://www.stratstone.com)E-Mail:

---

**West Midlands**

---

**Stratstone Aston Martin Hagley**

94-96 Kidderminster Rd., Hagley, DY9 0QL

Telephone: (+44) (0) 1562 888 380

Facsimile: (+44) (0) 1562 888 382

Web Site: [www.stratstone.com](http://www.stratstone.com)E-Mail: [birminghamastonmartin@stratstone.com](mailto:birminghamastonmartin@stratstone.com)

---

---

**West Sussex**

---

**Harwoods Aston Martin**

Terminus Rd., Chichester, PO19 8TX

Telephone: (+44) (0)1243 836500

Facsimile: (+44) (0)1243 836525

Web Site: [www.harwoods.uk.com/astonmartin](http://www.harwoods.uk.com/astonmartin)E-Mail: [infoasm@harwoods.uk.com](mailto:infoasm@harwoods.uk.com)

---

**West Yorkshire**

---

**JCT 600 Aston Martin Brooklands**

Ring Road, Lower Wortley, Leeds, LS12 6AA

Telephone: (+44) (0) 844 844 3101

Facsimile: (+44) (0)1133 890778

Web Site: [www.jct600.co.uk](http://www.jct600.co.uk)E-Mail: [astonmartin.sales@jct600.co.uk](mailto:astonmartin.sales@jct600.co.uk)

---

## France

---

### Bordeaux

---

#### Auto Performance Bordeaux

114 Avenue JF Kennedy, 33700 Mérignac

Telephone: (+33) 5 56 16 21 00

Facsimile: (+33) 5 56 16 21 01

Web Site: [www.astonmartinbordeaux.com](http://www.astonmartinbordeaux.com)

E-Mail: [contact@astonmartinbordeaux.com](mailto:contact@astonmartinbordeaux.com)

---

### Cannes

---

#### Royal Motors Cannes

1390 Ave. du Campon, 06110 Cannes

Telephone: (+33) 4 93 94 84 84

Facsimile: (+33) 4 92 18 16 01

Web Site: [www.aston-martin-cannes.com](http://www.aston-martin-cannes.com)

E-Mail: [commercial@royal-motor.com](mailto:commercial@royal-motor.com)

---

### Lyon

---

#### Auto Performance Lyon

5, Avenue du Maréchal Foch, 69006 LYON

Telephone: (+33) (0) 4 37 48 07 07

Facsimile: (+33) (0) 4 37 48 07 08

Web Site: [www.astonmartinlyon.com](http://www.astonmartinlyon.com)

E-Mail: [contact@astonmartinlyon.com](mailto:contact@astonmartinlyon.com)

---

### Paris

---

#### Auto Performance Paris

25 Ave. Franklin D Roosevelt, 75008 Paris

Telephone: (+33) 1 40 75 20 85

Facsimile: (+33) 1 40 75 20 86

Web Site: [www.astonmartinparis.com](http://www.astonmartinparis.com)

E-Mail: [contact@astonmartinparis.com](mailto:contact@astonmartinparis.com)

---

## Germany

---

### Aachen

---

#### Hauswirth Exclusive Cars GMBH

Europaplatz 17-19, 52068 Aachen

Telephone: (+49) 241 16604 22

Facsimile: (+49) 241 16604 41

Web Site: [www.astonmartin-aachen.de](http://www.astonmartin-aachen.de)

E-Mail: [info@astonmartin-aachen.de](mailto:info@astonmartin-aachen.de)

---

### Allgäu

---

#### Aston Martin Allgäu

Teramostraße 40, 87700

Telephone: (+49) 8331 974450

Facsimile: (+49) 8331 97445 - 15

Web Site: [www.astonmartin-allgaeu.de](http://www.astonmartin-allgaeu.de)

E-Mail: [info@astonmartin-allgaeu.de](mailto:info@astonmartin-allgaeu.de)

---

---

**Berlin**

---

**Krauthahn Berlin**

Nestorstraße 27–29, 10709 Berlin

Telephone: (+49) 30 89 60 000

Facsimile: (+49) 30 89 31 667

Web Site: [www.krauthahn-berlin.de](http://www.krauthahn-berlin.de)E-Mail: [service@krauthahn-berlin.de](mailto:service@krauthahn-berlin.de)

---

**Bremen**

---

**Tamsen GMBH**

Hauptstraße 55 (B 51), 28816 Stuhr, Bremen

Telephone: (+49) 421 80 95 80

Facsimile: (+49) 421 80 95 840

Web Site: [www.tamsen.de](http://www.tamsen.de)E-Mail: [info@tamsen.de](mailto:info@tamsen.de)

---

**Cologne**

---

**Royal Motors Kempen GMBH**

Raderthalgürtel 2, 50968 Cologne

Telephone: (+49) 2 21 9347 800

Facsimile: (+49) 2 21 380 488

Web Site: [www.astonmartin-koeln.de](http://www.astonmartin-koeln.de)E-Mail: [info@astonmartin.koeln.de](mailto:info@astonmartin.koeln.de)

---

**Dortmund**

---

**Aston Martin Dortmund**

Hannoversche Straße 44, 44143 Dortmund

Telephone: (+49) 231 91 20 4067

Facsimile: (+49) 231 91 20 4049

Web Site: [www.premiumcars-peters.de](http://www.premiumcars-peters.de)

E-Mail:

---

**Dresden**

---

**Thomas Exclusive Cars GMBH**

Meissner Straße 34, 01445 Radebeul

Telephone: (+49) 351 404 6420

Facsimile: (+49) 351 404 6410

Web Site: [www.astonmartin-dresden.de](http://www.astonmartin-dresden.de)E-Mail: [info@astonmartin-dresden.de](mailto:info@astonmartin-dresden.de)

---

**Düsseldorf**

---

**Aston Martin Düsseldorf**

Willstatterstr. 45, 40549 Düsseldorf

Telephone: (+49) 211 9446 01

Facsimile: (+49) 211 9446 1730

Web Site: [www.astonmartin-duesseldorf.de](http://www.astonmartin-duesseldorf.de)E-Mail: [info@astonmartin-duesseldorf.de](mailto:info@astonmartin-duesseldorf.de)

---

**Frankfurt**

---

**Aston Martin Kronberg**

Frankfurter Straße, 61476 Kronberg T/S, Frankfurt

Telephone: (+49) 6173 999680

Facsimile: (+49) 6173 64873

Web Site: [www.astonmartin-kronberg.de](http://www.astonmartin-kronberg.de)

E-Mail:

---

**Hamburg**

---

**Tamsen GMBH**

Merkurring 2, 22143 Hamburg

Telephone: (+49) 405 700 3000

Facsimile: (+49) 405 700 3040

Web Site: [www.tamsen.de](http://www.tamsen.de)E-Mail: [info@tamsen.de](mailto:info@tamsen.de)

---

**Hannover**

---

**Aston Martin Hannover**

Podbielskistrasse 322, 30655 Hannover

Telephone: (+49) 511 897 8890

Facsimile: (+49) 511 358 55-66

Web Site: [www.kamps-hannover.de](http://www.kamps-hannover.de)E-Mail: [kamps-hannover@kamps-gruppe.de](mailto:kamps-hannover@kamps-gruppe.de)

---

**Mannheim**

---

**Kroymans Autohaus Mannheim GMBH**

Saarburger Ring 19–21, 68229 Mannheim

Telephone: (+49) 621 48380 0

Facsimile: (+49) 621 48380 99

Web Site: [www.kroymans-mannheim.de](http://www.kroymans-mannheim.de)

E-Mail:

---

**Mannheim**

---

**Kroymans Autohaus Mannheim GMBH**

Saarburger Ring 19–21, 68229 Mannheim

Telephone: (+49) 621 48380 0

Facsimile: (+49) 621 48380 99

Web Site: [www.kroymans-mannheim.de](http://www.kroymans-mannheim.de)

E-Mail:

---

**München**

---

**Aston Martin München**

Odeonsplatz 2, 80539 München

Telephone: (+49) 89 287 0120

Facsimile: (+49) 89 287 012 22

Web Site: [www.astonmartin-muenchen.de](http://www.astonmartin-muenchen.de)

E-Mail:

---

## Stuttgart

---

### Aston Martin Stuttgart

Cannstatter Straße 46, 70190 Stuttgart

Telephone: (+49) 711 2803 3600

Facsimile: (+49) 711 2803 3615

Web Site: [www.astonmartin-stuttgart.de](http://www.astonmartin-stuttgart.de)

E-Mail:

---

## Holland

---

### Eindhoven

---

#### Cito Motors B.V.

Huizingalaan 66, 5628 CM Eindhoven

Telephone: (+31) 40 29 01 110

Facsimile: (+31) 40 24 14 956

Web Site: [www.citomotors.nl](http://www.citomotors.nl)

E-Mail: [info@astonmartineindhoven.nl](mailto:info@astonmartineindhoven.nl)

---

### Hilversum

---

#### Kroymans Aston Martin B.V.

Soestdijkerstraatweg 66, 1213 XE Hilversum

Telephone: (+31) 35 646 2230

Facsimile: (+31) 35 683 5646

Web Site: [www.astonmartin.nl](http://www.astonmartin.nl)

E-Mail: [info@astonmartin.nl](mailto:info@astonmartin.nl)

---

## Hong Kong

---

### MF Jebsen Automotive Ltd.

G/F., 196-200 Tsz Tsz Mui Rd., North Point, Hong Kong

Telephone: (+852) 2366 2017

Facsimile: (+852) 2191 9117

Web Site: [www.mfjebsen.com](http://www.mfjebsen.com)

E-Mail: [automotive@mfjebsen.com](mailto:automotive@mfjebsen.com)

## Italy

---

### Bologna

---

**EmilianAuto Spa.**

Via de Carracci 6, 40131 Bologna

Telephone: (+39) 0 51 638 2111

Facsimile: (+39) 0 51 638 2202

Web Site: [www.astonmartinbologna.it](http://www.astonmartinbologna.it)

E-Mail: [info@astonmartinbologna.it](mailto:info@astonmartinbologna.it)

---

### Milano

---

**Aston Martin Milano S.R.L.**

Via Monte Rosa, 91, 20149 Milano

Telephone: (+39) 02 43510988

Facsimile: (+39) 02 42511652

Web Site: [www.astonmartinmilano.it](http://www.astonmartinmilano.it)

E-Mail: [info@astonmartinmilano.it](mailto:info@astonmartinmilano.it)

---

### Padova

---

**Aston Martin Padova S.R.L.**

Via Nona Strada, 23/L, 35129 Padova

Telephone: (+39) 049 807 9516

Facsimile: (+39) 049 807 9464

Web Site: [www.astonmartinpadova.it](http://www.astonmartinpadova.it)

E-Mail: [info@astonmartinpadova.it](mailto:info@astonmartinpadova.it)

---

### Rome

---

**Aston Martin Roma**

Via F. Siacci 44, 00197 Rome

Telephone: (+39) 06808 2487

Facsimile: (+39) 06808 2415

Web Site: [www.astonmartinroma.it](http://www.astonmartinroma.it)

E-Mail: [info@astonmartinroma.it](mailto:info@astonmartinroma.it)

---

## Japan

---

### Nagoya

---

**Aston Martin Nagoya Hakko**

2-44-20 Shinsakae, Naka-ku, Nagoya 460-0007

Telephone: (+81) (0)52 242 0888

Facsimile: (+81) (0)52 242 0878

Web Site: [www.astonmartin-nagoya.com](http://www.astonmartin-nagoya.com)

E-Mail: [astonmartin-nagoyaa@hakko-group.co.jp](mailto:astonmartin-nagoyaa@hakko-group.co.jp)

---

### Osaka

---

**Aston Martin Osaka Hakko**

1-19-1 Kitahorie, Nishi-ku, Osaka 550-0014

Telephone: (+81) (0)6 6531 0078

Facsimile: (+81) (0)6 6531 0118

Web Site: [www.astonmartin-osaka.co.jp](http://www.astonmartin-osaka.co.jp)

E-Mail: [astonmartin-osaka@hakko-group.co.jp](mailto:astonmartin-osaka@hakko-group.co.jp)

---

## Middle East

### Tokyo

#### Aston Martin Akasaka

Akasaka Showroom, 4-9-25 Akasaka, Minato-ku, Tokyo 107-0052

Telephone: (+81) (0)3 5411 2332

Facsimile: (+81) (0)3 3479 0774

Web Site: [www.astonmartin-akasaka.com](http://www.astonmartin-akasaka.com)

E-Mail: [info@astonmartin-akasaka.com](mailto:info@astonmartin-akasaka.com)

#### Atlantic Cars Limited

2-3-3 Azabudai, Minato-ku, Tokyo 106-0041

Telephone: (+81) (0)3 3583 8611

Facsimile: (+81) (0)3 3583 8613

Web Site: [www.astonmartin.co.jp](http://www.astonmartin.co.jp)

E-Mail: [atlantic\\_cars@astonmartin.co.jp](mailto:atlantic_cars@astonmartin.co.jp)

### Al-Khobar

#### Haji Hussein Alireza

King Faisal Rd., PO Box 269, Al-Khobar

Telephone: (+966) 3 887 8087

Facsimile: (+966) 3 887 9690

Web Site: [www.hha.com.sa](http://www.hha.com.sa)

E-Mail: [contact@hha.com.sa](mailto:contact@hha.com.sa)

### Bahrain

#### Montana Motors

PO Box 28070, Riffa

Telephone: (+973) 1 766 9999

Facsimile: (+973) 1 766 8888

Web Site: [www.montanamotors.com](http://www.montanamotors.com)

E-Mail: [montana@batelco.com.bh](mailto:montana@batelco.com.bh)

### Beirut

#### Mana Automotive S.A.L.

Aston Martin & Land Rover Building, Chouran, Unesco, Verdun,  
PO Box 11-5800, Beirut

Telephone: (+961) 1 771000

Facsimile: (+961) 1 785205

Web Site:

E-Mail: [astonmartin@tewtelgroup.com](mailto:astonmartin@tewtelgroup.com)

### Doha

#### Horizon Automobiles

PO Box 37554

Telephone: (+974) 594 4111

Facsimile: (+974) 458 2444

Web Site:

E-Mail:

---

**Dubai**

---

**Al Habtoor Motors Co. (LLC)**

Al Ittihad Rd, Dubai

Telephone: (+971) 4 295 6232

Facsimile: (+971) 4 294 4422

Web Site:

E-Mail:

---

**Jeddah**

---

**Haji Hussein Alireza**

PO Box 40, Jeddah 21411

Telephone: (+966) 2 642 3509

Facsimile: (+966) 2 642 6435

Web Site: [www.hha.com.sa](http://www.hha.com.sa)E-Mail: [contact@hha.com.sa](mailto:contact@hha.com.sa)

---

**Kuwait**

---

**Premier International Motors Group Co WLL**

Alghazali Road, PO Box 5963, Safat

Telephone: (+965) 1824242

Facsimile: (+965) 22324811

Web Site:

E-Mail: [info@astonmartin-kuwait.com](mailto:info@astonmartin-kuwait.com)

---

**Riyadh**

---

**Haji Hussein Alireza**

PO Box 87106

Telephone: (+966) 1 493 4444

Facsimile: (+966) 1 493 6443

Web Site: [www.hha.com.sa](http://www.hha.com.sa)E-Mail: [contact@hha.com.sa](mailto:contact@hha.com.sa)

---

**Monaco**

---

---

**Monte Carlo**

---

**British Motors SAM**

15 Blvd. Princesse Charlotte, 98000 Monte Carlo

Telephone: (+377) 97 978 978

Facsimile: (+377) 97 978 989

Web Site: [www.aston-martin-monaco.com](http://www.aston-martin-monaco.com)E-Mail: [british-motors@british-motors.mc](mailto:british-motors@british-motors.mc)



## New Zealand

---

### Auckland

---

#### Independent Prestige Limited

150 Great North Rd., Grey Lynn, Auckland

Telephone: (+64) (0) 9 360 3202

Facsimile: (+64) (0) 9 361 6403

Web Site: [www.astonmartin.co.nz](http://www.astonmartin.co.nz)

E-Mail: [sales@iprestige.co.nz](mailto:sales@iprestige.co.nz)

## Northern Ireland

---

### Antrim

---

#### Charles Hurst Limited

62 Boucher Rd., Belfast, BT12 6LR

Telephone: (+44) (0) 28 9038 1721

Facsimile: (+44) (0) 28 9066 2355

Web Site: [www.charleshurstgroup.co.uk](http://www.charleshurstgroup.co.uk)

E-Mail:

## Norway

---

### Oslo

---

#### As Insignia

Sofienberggaten 35, N-0558 Oslo

Telephone: (+47) 2323 3377

Facsimile: (+47) 2323 3301

Web Site: [www.insignia.no](http://www.insignia.no)

E-Mail:

## Poland

---

### Warszawa

---

#### Aston Martin Warszawa

03-910 Warszawa, Waszyngtona 50

Telephone:

Facsimile:

Web Site:

E-Mail:

## Portugal

---

### Lisbon

---

#### AML Sport S.A. Lisboa

Rua António Enes 21 A, 1050-023 Lisbon

Telephone: (+351) 21 31 47 731

Facsimile: (+351) 21 31 92 389

Web Site:

E-Mail:

### Porto

---

#### AML Sport, S.A

Rua Delfim Ferreira, 424-460, 4100-199 Porto

Telephone: (+351) 226 158 620

Facsimile: (+351) 226 158 639

Web Site:

E-Mail:

## Russia

---

### Moscow

---

#### Aston Martin Moscow

1, Kutuzovsky prospect, Moscow 121248

Telephone: (+7) 495 229 0007

Facsimile: (+7) 495 258 1667

Web Site: [www.astonmartin.ru](http://www.astonmartin.ru)

E-Mail: [info@astonmartin.ru](mailto:info@astonmartin.ru)

## Scotland

---

### Lothian

---

#### Murray Motor Company

6 Bankhead Drive, Sighthill, Edinburgh, EH11 4DJ

Telephone: (+44) (0) 131 442 2800

Facsimile: (+44) (0) 131 468 7219

Web Site: [www.murrayastonmartin.co.uk](http://www.murrayastonmartin.co.uk)

E-Mail: [murraymotorco@jmggroup.co.uk](mailto:murraymotorco@jmggroup.co.uk)

## Singapore

---

#### Aston Martin Lagonda (SEA) PTE Ltd.

Number 1, Tuas Basin Link, Singapore 638755

Telephone: (+65) 6862 5868

Facsimile: (+65) 6862 5388

Web Site: [www.astonmartin.com.sg](http://www.astonmartin.com.sg)

E-Mail: [enquiries@astonmartin.com.sg](mailto:enquiries@astonmartin.com.sg)

## South Africa

---

### Cape Town

---

#### Aston Martin Cape Town

The V & A Waterfront, Corner Dock Rd. and Breakwater Blvd., Cape Town 8002

Telephone: (+27) 21 425 2007

Facsimile: (+27)

Web Site:

E-Mail:

### Johannesburg

---

#### Aston Martin Sandton

Sandton Isle, Corner Rivonia and Linden Rd., Sandton 2196

Telephone: (+27) 11 301 7100

Facsimile: (+27) 11 301 7101

Web Site:

E-Mail: [info@astonmartin.co.za](mailto:info@astonmartin.co.za)

## Spain

---

### Barcelona

---

#### Aston Martin Barcelona

Roger de Llúria, 115, 08037 Barcelona

Telephone: (+34) 93 215 21 70

Facsimile: (+34) 93 215 21 74

Web Site: [www.astonbcn.com](http://www.astonbcn.com)

E-Mail: [ventas.astonmartin@quadis.es](mailto:ventas.astonmartin@quadis.es)

### Madrid

---

#### C. de Salamanca SA

Zurbano, 93-95, 28003 Madrid

Telephone: (+34) 91 554 8293

Facsimile: (+34) 91 553 5206

Web Site: [www.cdesalamanca.com](http://www.cdesalamanca.com)

E-Mail: [ventas.zb@cdesalamanca.com](mailto:ventas.zb@cdesalamanca.com)

### Marbella

---

#### C. de Salamanca SA

Carretera de Cádiz, KM 171, San Pedro de Alcántara, 29670 Marbella

Telephone: (+34) 952 78 52 50

Facsimile: (+34) 952 78 03 66

Web Site: [www.cdesalamanca.com](http://www.cdesalamanca.com)

E-Mail: [ventas1.spedro@cdesalamanca.com](mailto:ventas1.spedro@cdesalamanca.com)

### Valencia

---

#### Aston Martin Valencia

Calle Ibiza, 1, 46023 Valencia

Telephone: (+34) 96 331 98 08

Facsimile: (+34) 96 331 98 14

Web Site: [www.astonmartINVALencia.com](http://www.astonmartINVALencia.com)

E-Mail: [ventas.astonmartin@quadis.es](mailto:ventas.astonmartin@quadis.es)

## Sweden

---

### Stockholm

---

Aston Martin Stockholm

Rinkebyvagen 9, S-182 36, Danderyd, Stockholm

Telephone:

Facsimile:

Web Site:

E-Mail:

## Switzerland

---

### Geneva

---

#### Keller Motorcars Geneva

Rue du Grand Pré 2, 1202 Geneva

Telephone: (+41) 22 919 0500

Facsimile: (+41) 22 919 0509

Web Site: [www.kellermotorcars.ch](http://www.kellermotorcars.ch)

E-Mail: [geneve@kellermotorcars.ch](mailto:geneve@kellermotorcars.ch)

---

### Lugano

---

#### Garage Tarcisio Pasta SA

Via Monteceneri 1, 6593 Cadenazzo

Telephone: (+41) (0) 91 850 2024

Facsimile: (+41) (0) 91 850 2021

Web Site: [www.tpasta.ch](http://www.tpasta.ch)

E-Mail: [astonmartin@tpasta.ch](mailto:astonmartin@tpasta.ch)

---

### Safenwil

---

#### Emil Frey AG

Autocenter Safenwil, Industrie Nord, 5745 Safenwil

Telephone: (+41) 62 788 8807

Facsimile: (+41) 62 788 84 33

Web Site: [www.astonmartin.ch](http://www.astonmartin.ch)

E-Mail: [astonmartin-safenwil@emilfrey.ch](mailto:astonmartin-safenwil@emilfrey.ch)

---

### Zurich

---

#### Emil Frey AG

Badenerstrasse 600, 8048 Zurich

Telephone: (+41) (0) 44 495 2515

Facsimile: (+41) (0) 44 495 2305

Web Site: [www.astonmartin.ch](http://www.astonmartin.ch)

E-Mail: [astonmartin@emilfrey.ch](mailto:astonmartin@emilfrey.ch)

---

## Taiwan

---

### Taipei

---

Aston Martin Taipei

Telephone: (+886) 2 2836 8899

Facsimile: (+886) 2 2835 8899

Web Site:

E-Mail:

---

## United States of America

---

### Arizona

---

#### Aston Martin Scottsdale

6825 East McDowell Rd., Scottsdale, AZ 85257

Telephone: (+1) 480 421 7240

Facsimile: (+1) 480 421 3805

Web Site: [www.astonmartinscottsdale.com](http://www.astonmartinscottsdale.com)

E-Mail:

### California

---

#### Aston Martin Marin

195 Casa Buena Drive, Corte Madera, CA 94925

Telephone: (+1) 415 496 2100

Facsimile: (+1) 415 496 2170

Web Site: [www.astonmartinmarin.com](http://www.astonmartinmarin.com)

E-Mail:

#### Aston Martin of Beverly Hills

8833 West Olympic Blvd., Beverly Hills, CA 90211

Telephone: (+1) 310 659 4050

Facsimile: (+1) 310 625 9656

Web Site: [www.astonmartinbeverlyhills.com](http://www.astonmartinbeverlyhills.com)

E-Mail:

#### Aston Martin of Newport Beach

1540 Jamboree Rd., CA 92660

Telephone: (+1) 949 999 5500

Facsimile: (+1) 949 999 5501

Web Site: [www.amofoc.com](http://www.amofoc.com)

E-Mail: [sales@amofoc.com](mailto:sales@amofoc.com)

#### Aston Martin of San Diego

5202 Kearney Mesa Rd., San Diego, CA 92111

Telephone: (+1) 858 541 0200

Facsimile: (+1) 858 541 7696

Web Site: [www.astonmartinofsandiego.com](http://www.astonmartinofsandiego.com)

E-Mail:

#### Aston Martin Silicon Valley

66 East Main St., Los Gatos, CA 95030

Telephone: (+1) 408 354 4000

Facsimile: (+1) 408 354 6285

Web Site: [www.astonmartinsiliconvalley.com](http://www.astonmartinsiliconvalley.com)

E-Mail:

---

**Desert European**

71-387 Highway 111, Rancho Mirage, CA 92270

Telephone: (+1) 760 773 5000

Facsimile: (+1) 760 773 4406

Web Site: [www.deserteuropean.com](http://www.deserteuropean.com)

E-Mail:

**Galpin Aston Martin**

15500 Roscoe Blvd., Van Nuys, CA 91406

Telephone: (+1) 818 894 3800

Facsimile: (+1) 818 922 3668

Web Site: [www.galpinastonmartin.com](http://www.galpinastonmartin.com)

E-Mail:

---

**Colorado****Sill-Terhar Aston Martin**

PO Box 344, Broomfield, Denver, CO 80038

Telephone: (+1) 303 469 1801

Facsimile: (+1) 720 284 0792

Web Site: [www.sthmotors.com](http://www.sthmotors.com)

E-Mail:

---

**Connecticut****Miller Motorcars Inc.**

275 West Putnam Ave., Greenwich, CT 06830

Telephone: (+1) 203 629 4726

Facsimile: (+1) 203 629 3418

Web Site: [www.millermotorcars.com](http://www.millermotorcars.com)

E-Mail:

---

**Florida****Aston Martin Naples**

850 Tamiami Trail North, Naples, FL 34102

Telephone: (+1) 866 603 6020

Facsimile: (+1) 239 262 2848

Web Site: [www.astonmartinnaples.com](http://www.astonmartinnaples.com)

E-Mail:

**Aston Martin Orlando**

4249 Millenia Blvd, Orlando, FL 32839

Telephone: (+1) 407 472 4880

Facsimile: (+1) 407 472 4899

Web Site: [www.astonmartinorlando.com](http://www.astonmartinorlando.com)

E-Mail:

---

**Aston Martin of Tampa Bay**

320 East Fletcher Ave., Tampa, FL 33612

Telephone: (+1) 813 371 8200

Facsimile: (+1) 813 371 8182

Web Site: [www.astonmartinoftampa.com](http://www.astonmartinoftampa.com)E-Mail: [info@astonmartinoftampa.com](mailto:info@astonmartinoftampa.com)**Aston Martin Palm Beach**

915 South Dixie Highway, West Palm Beach, FL 33401

Telephone: (+1) 561 659 6206

Facsimile: (+1) 561 832 7176

Web Site: [www.palmbeachmotorcars.com](http://www.palmbeachmotorcars.com)

E-Mail:

---

**The Collection**

200 Bird Rd., Coral Gables, FL 33146

Telephone: (+1) 305 476 2050

Facsimile: (+1) 786 924 5516

Web Site: [www.thecollection.com](http://www.thecollection.com)

E-Mail:

---

**Georgia****Aston Martin of Atlanta**

11875 Alpharetta Highway, Roswell, GA 30076

Telephone: (+1) 678 802 5007

Facsimile: (+1) 678 802 5019

Web Site: [www.astonmartinofatlanta.com](http://www.astonmartinofatlanta.com)

E-Mail:

---

**Illinois****Lake Forest Sports Cars Limited**

990 North Shore Drive, Lake Bluff, IL 60044

Telephone: (+1) 847 295 6560

Facsimile: (+1) 847 295 8849

Web Site: [www.ifsc.com](http://www.ifsc.com)E-Mail: [sales@ifsc.com](mailto:sales@ifsc.com)

---

**Massachusetts****Aston Martin of New England**

85 Linden St., Waltham, MA 02452

Telephone: (+1) 781 547 5959

Facsimile: (+1) 781 547 5957

Web Site: [www.astonmartin-lotus.com](http://www.astonmartin-lotus.com)E-Mail: [lotusmotor@aol.com](mailto:lotusmotor@aol.com)



---

## Michigan

---

### Aston Martin of Troy

1767 Maplelawn, Troy, MI 48084

Telephone: (+1) 248 643 6900

Facsimile: (+1) 248 643 9261

Web Site: [www.astonmartinoftroy.com](http://www.astonmartinoftroy.com)

E-Mail: [info@astonmartinoftroy.com](mailto:info@astonmartinoftroy.com)

---

## Missouri

---

### Moore Aston Martin

14116 Manchester Rd., St. Louis, MO 63011

Telephone: (+1) 800 524 7278

Facsimile: (+1) 636 779 2024

Web Site: [www.moorejaguar.com](http://www.moorejaguar.com)

E-Mail:

---

## Nevada

---

### Gaudin Aston Martin of Las Vegas

7200 West Sahara Ave., Las Vegas, NV 89117

Telephone: (+1) 702 284 7000

Facsimile: (+1) 702 221 4422

Web Site: [www.jplv.net](http://www.jplv.net)

E-Mail:

---

## New Jersey

---

### F.C. Kerbeck Aston Martin

100 Route 73 North, Palmyra, NJ 08065

Telephone: (+1) 856 829 8200

Facsimile: (+1) 856 829 7009

Web Site: [www.fckerbeck.com](http://www.fckerbeck.com)

E-Mail: [info@fckerbeck.net](mailto:info@fckerbeck.net)

---

## Ray Catena Aston Martin

910 US Route 1, Edison, NJ 08817

Telephone: (+1) 732 205 9000

Facsimile: (+1) 732 205 9101

Web Site: [www.raycatena-astonmartin.com](http://www.raycatena-astonmartin.com)

E-Mail:

---

## New York

---

### Aston Martin Long Island

Aston Martin Long Island Sales, 1060 Northern Blvd., Roslyn, NY 11576

Telephone: (+1) 516 478 4326

Facsimile: (+1) 516 478 4327

Web Site: [www.astonmartinlongisland.com](http://www.astonmartinlongisland.com)

E-Mail:

---

**North Carolina**

---

**Aston Martin of Charlotte**

416 Tyvola Rd., Charlotte, NC 28217

Telephone: (+1) 704 535 7100

Facsimile: (+1) 704 536 1777

Web Site: [www.fcicharlotte.com](http://www.fcicharlotte.com)

E-Mail:

**Foreign Cars Aston Martin**

5603 Roanne Way, Greensboro, NC 27409

Telephone: (+1) 336 294 0200

Facsimile: (+1) 336 294 9109

Web Site: [www.foreigncarsitalia.com](http://www.foreigncarsitalia.com)

E-Mail:

**Ohio****Midwestern Auto Group**

6335 Perimeter Loop Rd., Dublin, OH 43017

Telephone: (+1) 614 889 2571

Facsimile: (+1) 614 793 7971

Web Site: [www.magastonmartin.com](http://www.magastonmartin.com)

E-Mail:

---

**Texas**

---

**Aston Martin of Austin**

12989 Research Blvd., Austin, TX 78750

Telephone: (+1) 512 918 1007

Facsimile: (+1) 512 249 9477

Web Site: [www.astonmartinofaustin.com](http://www.astonmartinofaustin.com)

E-Mail:

**Aston Martin Dallas**

5333 Lemmon Ave., Dallas, TX 75209

Telephone: (+1) 214 522 1007

Facsimile: (+1) 214 353 3550

Web Site: [www.astonmartindallas.com](http://www.astonmartindallas.com)

E-Mail:

**Star Motor Cars**

7000 Katy Rd., Houston, TX 77024

Telephone: (+1) 713 868 6813

Facsimile: (+1) 713 868 6814

Web Site: [www.starmotorcarsastonmartin.com](http://www.starmotorcarsastonmartin.com)E-Mail: [amsales@starmotors.com](mailto:amsales@starmotors.com)

---

---

## Wales

---

---

---

### Virginia

---

#### Aston Martin Tysons

8545 Leesbueg Pike, Vienna, VA 22182

Telephone: (+1) 571 216 8244

Facsimile: (+1) 703 564 6345

Web Site: [www.astonmartintysons.com](http://www.astonmartintysons.com)

E-Mail:

---

### Washington

---

#### Park Place Aston Martin

13710 NE 20th St., Bellevue, WA 98005

Telephone: (+1) 425 562 1000

Facsimile:

Web Site: [www.parkplaceastonmartin.com](http://www.parkplaceastonmartin.com)

E-Mail:

---

### South Glamorgan

---

#### Stratstone Cardiff

Cambria House, 156 North Rd., Cardiff, CF14 3BH

Telephone: (+44) (0) 2920 695700

Facsimile: (+44) (0) 2920 695718

Web Site: [www.stratstone.com](http://www.stratstone.com)

E-Mail: [cardiffastonmartin@stratstone.com](mailto:cardiffastonmartin@stratstone.com)



ASTON MARTIN



ASTON MARTIN



ASTON MARTIN



ASTON MARTIN

# Alphabetical Index

## A

Accessory Power Socket .....	3.27
Adaptive Damping .....	5.11
Airbags .....	3.11
Passenger Deactivation Switch .....	3.16
Alarm .....	2.10
Movement Sensor .....	2.10
Reduced Guard .....	2.10
Tilt Sensor .....	2.10
Ambient Temperature .....	4.16
Anti Corrosion Inspection .....	A.9
Anti-Lock Braking System .....	5.7
Ashtray and Cigar Lighter .....	3.27
Aston Martin Assistance .....	B.1
Aston Martin Tracking .....	2.2
Aston Martin Warranty .....	C.1
Audio .....	7.1
Battery Protection Mode .....	7.4
Essentials .....	7.2

Authorised Body Repairers .....	D.1
Authorised Service Centres .....	E.1
Automatic Lock .....	2.8
Automatic Transmission .....	5.3
Fault Conditions .....	5.6
Parklock Override .....	11.15
Sport Mode .....	5.5
Touchtronic Mode .....	5.5

## B

Battery .....	
Maintenance .....	11.20
Protection Mode .....	7.4
Battery Charge .....	11.20
Battery Conditioner .....	11.20
Battery Disposal .....	11.19
Battery Protection Mode .....	11.21
Bonnet Release .....	11.6
Boot Lid .....	2.7
Boot Storage .....	3.23

Brake Pad 'Bedding-in' .....	11.11
Brakes .....	
Anti-Lock Braking System .....	5.7
Park Brake .....	5.8

## C

Cabin Storage .....	3.24
Catalytic Converters .....	5.13
Child Locks .....	2.6
Child Seats .....	3.20
Passenger Airbag Deactivation .....	3.16
Climate Control .....	
Automatic Operation .....	6.6
Controls .....	6.2
Manual Operation .....	6.6
Operating Tips .....	6.2
Coat Hooks .....	3.30
Condensation, Headlamp Units .....	11.28
Controls .....	
Centre .....	4.8

Information and Warning Symbols .....	4.5	Front Seat Reset .....	11.31	Homesafe .....	2.9
Instrument Cluster .....	4.3	Fuel		<b>I</b>	
Stalk .....	4.11	Catalytic Converters .....	5.13	Interior Mirrors .....	3.6
Cruise Control .....	4.15	Fuel Filling .....	5.12	Internal Lamps .....	11.29
<b>D</b>		Fuse Boxes .....	11.22	<b>J</b>	
Dangerous Substances .....	11.4	<b>G</b>		Jump Start From Another Vehicle .....	11.17
Data Recording .....	1.3	Garage Door Opener .....	2.12	<b>L</b>	
Day Time Running .....	4.12	Garage Door Opener (Option)		Lamps .....	4.12
Dealer Directory .....	F.1	Operation .....	2.13	Locking the Vehicle .....	2.5
Defrosting and Demisting		Programming .....	2.13	Low Outside Temperature Warning .....	4.7
Automatic .....	6.6	Reprogramming .....	2.14	<b>M</b>	
Manual .....	6.7	Rolling Code Synchronisation .....	2.14	Maintenance .....	11.1, 11.5
Driving Techniques .....	5.15	<b>H</b>		Vehicle Jacking .....	11.3
Dynamic Stability Control .....	5.9	Hands-Free Phone .....	9.1	Maintenance Items	
<b>E</b>		Connecting a Phone .....	9.4	Battery Conditioner .....	11.6
Electric Windows .....	3.28	Removing a Phone .....	9.6	Tool Kit .....	11.6
Emotion Control Unit .....	2.3	Using a Phone .....	9.7	Master Lamp .....	4.12
<b>F</b>		Headlamp Adjustment. Tourist, .....	11.30	Master Vehicle Lock .....	2.5
Fluid Levels .....	11.7	Headlamp Bulb .....	11.28	Media Devices .....	3.26
Footbrake .....	5.7	Headlamp Condensation .....	11.28		

Memory Seats .....	3.5
Mirrors	
Auto Fold Function (Door Mirrors) .....	3.7
Door .....	3.6
Interior .....	3.6
Power Fold Function (Door Mirrors) .....	3.6
Reverse Dip Function (Door Mirrors) .....	3.7
<b>P</b>	
Park Brake .....	5.8
Parking Assist	
Front and Rear .....	5.13
Rear Only .....	5.15
Passenger Airbag Deactivation .....	3.15
Passive Anti-Theft System .....	2.11
<b>R</b>	
Rear Seat Entertainment .....	8.1
Replacement of Airbag Units Record .....	A.10
Replacement of Seat Belt Pre-tensioners Record ....	A.11
Restraints System .....	3.8
Determining if the System is Operational .....	3.8

<b>S</b>	
Safety Defects - Reporting .....	1.4
Satellite Navigation .....	10.1
Advanced Mode .....	10.12
Advanced Mode Settings .....	10.9
Demo .....	10.5
Easy Mode .....	10.7
Easy Mode Settings .....	10.6
Map Updates .....	10.2
System Controls .....	10.3
Seat Adjustment .....	3.2
Seat Belts .....	3.8
Care and Maintenance .....	11.33
Child .....	3.11
Seats	
Memory Function .....	3.5
Temperature Controlled .....	3.4
Servicing .....	A.4
Specifications .....	12.1
Steering Wheel .....	3.6
Storage .....	3.23, 3.24

Supplemental Restraints System .....	3.11
<b>T</b>	
Temperature Controlled Seats .....	3.4
Track Days .....	5.16
Traction Control .....	5.10
Trip .....	4.14
Tyre .....	4.17
Tyre Sealant Kit .....	11.13
<b>U</b>	
Unlocking the Vehicle .....	2.4
<b>V</b>	
Vehicle Battery .....	11.18
Vehicle Horn .....	4.13
Vehicle Identification .....	1.3
Vehicle Key .....	2.3
Vehicle Recovery .....	11.15
Vehicle Storage .....	11.34
<b>W</b>	
Wheel Nut Torque .....	12.5

Window Reset ..... 11.30  
Windscreen Blade Replacement ..... 11.10  
Wipers  
    Wiper ..... 4.12



ASTON MARTIN



ASTON MARTIN